

---

**Cooperative Spectrum Sensing under Correlated  
Shadowing based on Fuzzy Logic in Multi-Hop  
Cognitive Radio Networks**

---

ATTIKEY M. WILLY

EE 300-0004/15

A thesis submitted to Pan African University Institute for Basic Sciences,  
Technology and Innovation in partial fulfilment of the requirements for the  
award of the degree of Master in Electrical Engineering - Telecommunication  
option

2017

## Declaration

This research thesis is my original work, except where due acknowledgement is made in the text, and to the best of my knowledge has not been previously submitted to Pan African University or any other institution for the award of a degree or diploma.

Name: ATTIKEY M. WILLY

Reg. Num.: EE 300-0004/15

Signature \_\_\_\_\_

Date \_\_\_\_\_

**TITLE OF THESIS:** COOPERATIVE SPECTRUM SENSING UNDER CORRELATED SHADOWING BASED ON FUZZY LOGIC IN MULTI-HOP COGNITIVE RADIO NETWORKS

**PROGRAMME:** MASTER OF SCIENCE IN ELECTRICAL ENGINEERING TELECOMMUNICATION OPTION

### **SUPERVISOR CONFIRMATION:**

This research thesis has been submitted to the Pan African University Institute for Basic Sciences, Technology and Innovation with our approval as the supervisors:

Signature \_\_\_\_\_

Dr. Peter Kihato

Date \_\_\_\_\_

Signature \_\_\_\_\_

Prof. Vitalice Oduol

Date \_\_\_\_\_

## Dedication

I would like to dedicate this thesis to my family, lecturers and friends.

## Acknowledgement

Prima facie, I am grateful to God for the good health and well-being that were necessary to complete this work.

I would like to show my sincere gratitude to my supervisors, Prof. Vitalice Oduol and Dr Kihato Peter for their continuous support, for their patience, motivation, and immense knowledge. My sincere thank goes to the African Union Commission, the Pan African University-Institute for basic Sciences, Technology and Innovation and Jomo Kenyatta University of Agriculture and Technology's staff for providing us with all the required facilities for the research. I would like also to extend my thank and gratitude to Dr Kibet Langat, Coordinator of the Electrical Engineering Department, who has been available throughout this memorable journey.

To all my relatives, colleagues, friends and others who in any way shared their support either morally, physically or financially, thank you. Last but not the least, I am thankful to my family for supporting me throughout my studies and my everyday life.

Willy M. Attikey

March 1, 2017

## Abstract

Cognitive Radio has been invented to provide wireless communications with efficient radio spectrum utilization. The secondary users (SUs) can therefore, access opportunistically licensed band by sensing spectrum holes without interfering with primary users (PU) or keeping the interference, if it happens below a tolerable threshold. Main functions of cognitive radio are: Spectrum sensing, spectrum management, spectrum mobility and spectrum sharing. This research focuses on sensing and spectrum access optimization in cooperative multi-hop cognitive radio networks. In a cooperative spectrum sensing, nodes located in their vicinities can experience spatially correlated fading and it leads to a degraded detection performance. To combat that effect, it is has been demonstrated in several works that by selecting only spatially independent nodes, good results can be obtained. A fuzzy-based user selection is investigated to cope with the aforementioned issues in a multi-hop clustered cooperative spectrum sensing architecture. Moreover, many researchers have based their work on single-hop cognitive radio network architecture. However, this architecture does not portray practical environments whereby nodes can be located far from each other and will hence need their communication to be forwarded through relays. By optimizing fuzzy inputs, we are able to achieve a high detection performance in a multi-hop architecture by selecting only less correlated users to cooperate. By considering uncorrelated users individually, the developed fuzzy based detection system outperforms the distance based one by providing probability of detection 40% more than the distance-based one when the decorrelation distance is 30 meters. On the other hand, when the decorrelation distance takes respectively values of 65m and 100m, the system does not show any gain compared to the distance-based one. Finally, when using only uncorrelated users, the detection performance is approximately the double of the one when using correlated users.

## Résumé

La radio cognitive a été inventée pour fournir des communications sans fil avec une utilisation efficace du spectre radio. Les utilisateurs secondaires peuvent donc accéder à une bande sous licence de manière opportuniste en détectant des trous de spectre sans interférer avec les utilisateurs primaires (PU) ou en maintenant les interférences si elles se produisent en-dessous d'un seuil tolérable. Les principales fonctions de la radio cognitive sont: la détection du spectre, la gestion du spectre, la mobilité du spectre et le partage du spectre. Cette recherche se concentre sur la détection et l'optimisation de l'accès au spectre dans les réseaux coopératifs de radio cognitive multi-hop. Dans une détection de spectre coopérative, les nœuds situés trop proches peuvent souffrir d'ombrage spatialement corrélé ce qui entraîne une dégradation de la performance de détection. Pour combattre ce phénomène, il a été démontré dans plusieurs travaux que, en sélectionnant uniquement des nœuds spatialement indépendants, de bons résultats peuvent être obtenus. Une sélection d'utilisateurs basée sur la logique floue est étudiée pour faire face aux défis mentionnés ci-dessus dans une architecture multi-hop coopérative de spectre de détection. De plus, de nombreux chercheurs ont basé leur travail sur l'architecture de réseau à un saut. Cependant, cette architecture ne représente pas fidèlement un environnement pratique où les nœuds peuvent être situés loin les uns des autres et auront donc besoin de leurs pairs en tant que relais pour transmettre des données. En optimisant les variables d'entrées, nous sommes en mesure d'atteindre une performance de détection élevée en sélectionnant uniquement les utilisateurs moins corrélés à coopérer. Si l'on considère les utilisateurs non corrélés individuellement, le système de détection développé basé sur la logique floue surpasse celui basé sur la distance en fournissant une probabilité de détection 40 % supérieure lorsque la distance de décorrelation est de 30 mètres. D'autre part, lorsque la distance de décorrelation prend respectivement des valeurs de 65m et 100m, le système ne présente aucun gain par rapport à celui basé sur la distance. Enfin, lorsqu'on utilise uniquement des utilisateurs non corrélés, la performance de détection est approximativement le double de

celle atteinte en utilisant des utilisateurs corrélés.

# Table of Contents

<b>Declaration</b>	<b>ii</b>
<b>Dedication</b>	<b>iii</b>
<b>Acknowledgement</b>	<b>iv</b>
<b>Abstract</b>	<b>v</b>
<b>Résumé</b>	<b>vi</b>
<b>List of Tables</b>	<b>x</b>
<b>List of Figures</b>	<b>xi</b>
<b>Acronyms</b>	<b>xiii</b>
<b>1 Introduction</b>	<b>1</b>
1.1 Background of study . . . . .	1
1.2 Problem statement . . . . .	2
1.3 Justification of the study . . . . .	3
1.4 Objectives of the study . . . . .	3
1.4.1 General objective . . . . .	3
1.4.2 Specific objectives . . . . .	3
1.5 Scope of the study . . . . .	4
1.6 Structure of the thesis . . . . .	4
1.7 Note on publication . . . . .	5
<b>2 Literature review</b>	<b>6</b>
2.1 Cognitive Radio Network . . . . .	6
2.1.1 Definition of cognitive radio . . . . .	6
2.1.2 Spectrum sensing . . . . .	8
2.1.3 Cooperative spectrum sensing . . . . .	14
2.2 Fuzzy logic concepts . . . . .	16



2.2.1	Fuzzy sets . . . . .	17
2.2.2	Fuzzy membership functions . . . . .	18
2.2.3	Properties of fuzzy sets . . . . .	21
2.2.4	Operations on fuzzy sets . . . . .	21
2.2.5	Fuzzy system design . . . . .	23
2.3	Application of Fuzzy Logic in Cognitive Radio Networks . . . . .	25
<b>3</b>	<b>Design and Implementation</b>	<b>27</b>
3.1	Fuzzy logic . . . . .	27
3.1.1	Spatially correlated shadowing and smart user selection . . . . .	27
3.2	Cooperative spectrum sensing . . . . .	32
3.2.1	Local sensing . . . . .	32
3.2.2	Reporting . . . . .	34
3.2.3	Information fusion . . . . .	35
3.3	Multi-hop spectrum sensing model . . . . .	36
<b>4</b>	<b>Results and Discussion</b>	<b>38</b>
4.1	Selection of uncorrelated users . . . . .	38
4.2	Probability of detection based on fuzzy logic . . . . .	39
4.3	Cluster-based CSS . . . . .	41
<b>5</b>	<b>Conclusions and Future work</b>	<b>44</b>
5.1	Conclusion . . . . .	44
5.2	Future work . . . . .	45
	<b>References</b>	<b>52</b>
	<b>Appendix A Smart user selection based on fuzzy logic</b>	<b>53</b>
	<b>Appendix B Fuzzy logic detection system</b>	<b>55</b>
	<b>Appendix C Probability of detection Based on Fuzzy logic</b>	<b>58</b>
	<b>Appendix D Algorithm of multi-hop architecture</b>	<b>63</b>

# List of Tables

3.1	Rules base for fuzzy based user selection . . . . .	31
3.2	Rules base for fuzzy based spectrum sensing . . . . .	35

# List of Figures

1.1	Contrasting (a) SDR and (b) Cognitive Radio . . . . .	2
2.1	Spectrum hole concept . . . . .	7
2.2	Cognitive radio cycle . . . . .	8
2.3	Energy detection . . . . .	10
2.4	Matched filter detection . . . . .	10
2.5	Cyclostationary feature detector . . . . .	11
2.6	Multitaper spectral estimation block diagram . . . . .	12
2.7	Sensing accuracy and complexity of various sensing methods . . .	13
2.8	Various aspects of spectrum sensing for cognitive radio . . . . .	14
2.9	The Membership Function $\mu_{Fhot}$ . . . . .	17
2.10	Different Membership Functions: (a) triangle, (b) trapezoid, (c) Gaussian, (d) bell . . . . .	19
2.11	Fuzzy-set intersection . . . . .	22
2.12	Fuzzy-set union . . . . .	22
2.13	Complement . . . . .	23
2.14	Typical fuzzy logic controller architecture . . . . .	25
3.1	Network model for user selection . . . . .	29
3.2	Fuzzy based User selection system . . . . .	30
3.3	Membership functions of the User selection system . . . . .	31
3.4	Classification of cooperative sensing (a) centralized, (b) distributed, and (c) relay-assisted . . . . .	32
3.5	Detection system based on Fuzzy logic . . . . .	33
3.6	Membership functions . . . . .	34
3.7	Multi-hop architecture model . . . . .	37
4.1	Surface plot of the fuzzy based user selection . . . . .	38
4.2	Probability of detection of fuzzy logic user selection compared with distanced based selection . . . . .	39

4.3	Probability of detection of correlated users . . . . .	40
4.4	Cluster-based CSS probability of detection for different decorrelation distances . . . . .	41
4.5	Multi-hop Probability of detection for different decorrelation distance	42

# Acronyms

**AWGN** Additive White Gaussian Noise.

**CH** Cluster Head.

**CoG** Center of Gravity.

**CR** Cognitive Radio.

**CRN** Cognitive Radio Network.

**CRS** Cognitive Radio System.

**CSS** Cooperative Spectrum Sensing.

**FC** Fusion Center.

**FCC** Federal Communications Commission.

**ITU** International Telecommunication Union.

**MF** Membership Function.

**MHCRN** Multi-Hop Cognitive Radio Network.

**MoM** Mean of Maxima.

**PD** Probability of Detection.

**PDA** Personal Digital Assistant.

**PF** Probability of False alarm.

**PU** Primary User.

**UWB** Ultra Wide Band.

# Chapter 1

## Introduction

### 1.1 Background of study

During the last few decades, we have witnessed a very high increase of wireless devices simultaneously with spectrum greedy multimedia applications. Though, most of the spectrum bands have been allocated to licensed users, it has been noticed by regulatory structures that they were not efficiently used while radio spectrum was already a limited resource. Based on measurements of the Federal Communications Commission (FCC) done in New York State, temporal and geographical variations in the utilization of the allotted spectrum range from 15% to 85%[1]. While certain frequency bands like military and paging frequencies are under-utilized, cellular networks are encumbered in most parts of the world. To deal with this inefficient radio spectrum utilization, Cognitive Radio Network (CRN) have arisen. Cognitive radio is based on the well-known "Software-Defined Radio" but improves it by bringing some intelligence in detection of spectrum holes in the licensed users' radio band using spectrum sensing Figure 1.1[2].

It was during a seminar at the Royal Institute of Technology in Stockholm in 1998 that Joseph Mitola III originally suggested the cognitive radio's concept which was published in an article, the following year, by Mitola and Gerald Q. Maguire, Jr.. It was a breakthrough in wireless communications, described by Mitola as: *"The point in which wireless Personal Digital Assistant (PDA) and the related networks are sufficiently computationally intelligent about radio resources and related computer-to-computer communications to detect user communications needs as a function of use context, and to provide radio resources and wireless services most appropriate to those needs"* [3]. Cognitive radio has been proposed to increase spectrum efficiency by having the cognitive radios as secondary users to opportunistically access underutilized frequency bands. Spectrum sensing es-

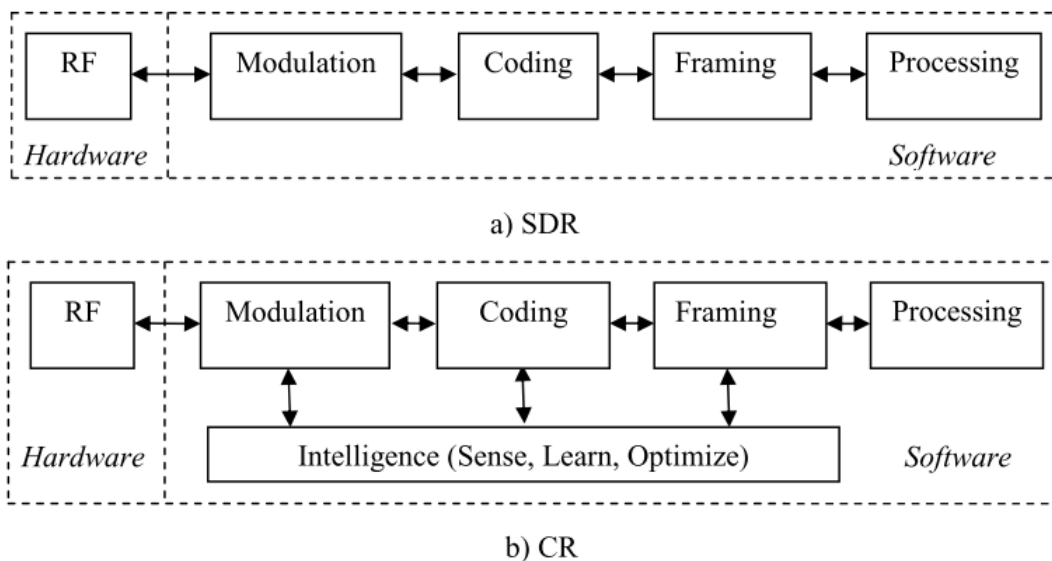

Figure 1.1: Contrasting (a) SDR and (b) Cognitive Radio

timations have to be trustworthy enough to avoid noise and harmful interference, and lead to accurate spectrum access decisions [4]. Actually, many researches are focused on achieving a good Dynamic Spectrum Access in CRN.

## 1.2 Problem statement

Cognitive Radio Networks have been proposed to deal with the wasteful radio spectrum utilization. Spectrum sensing is a major feature in CRN and actually many publications showed that cooperative spectrum sensing is the most used spectrum sensing technique which resolves the shadowing and multipath fading, and the receiver uncertainty problems by exploiting spatial diversity. A relevant survey is provided in [5, 6]. The cooperative gain is the result enhancement due to spatial diversity. To achieve a significant cooperative gain, many factors should be considered[5]. For example, when several cognitive users closely located at different positions are facing the same shadowing effects, it is called spatially correlated shadowing, thus the reporting results of those users are correlated. Correlated shadowing yields to a degraded performance of the overall sensing system. To alleviate correlated shadowing, the users cooperating should be selected in such

a way that they are experiencing independent fading[7].

The first part of this work will be focused on implementing a smart fuzzy-based user selection to combat correlated shadowing while the second part will focus on optimizing the probability of detection in a clustered multi-hop network architecture where nodes can relay each other information.

### **1.3 Justification of the study**

This study is being conducted owing to the fact that:

- i) The design of a smart scheme based on fuzzy logic, to resolve the spatially correlated shadowing challenge, remains a fresh area inefficiently covered.
- ii) To the best of our knowledge there is no research work on spectrum sensing and access optimization by using in combination cooperative spectrum sensing and fuzzy logic to combat correlated shadowing in Multi-Hop Cognitive Radio Network (MHCRN).

### **1.4 Objectives of the study**

#### **1.4.1 General objective**

The main objective is to optimize the detection performance of the secondary network by combating correlated shadowing through a smart user selection based on Fuzzy Logic in multi-hop cognitive networks.

#### **1.4.2 Specific objectives**

- i) To develop a smart fuzzy based user selection to combat the spatially correlated shadowing;
- ii) To implement a detection approach based also on fuzzy logic where less correlated users cooperate in a clustering fashion;
- iii) To provide an optimal overall system of detection in MHCRN.



## 1.5 Scope of the study

The scope of this thesis is limited to the technical and analytical features of an optimized cooperative spectrum sensing scheme based on fuzzy logic for dynamic spectrum sensing in MHCRN. The aim is to combat spatially correlated shadowing by selecting uncorrelated users to cooperate. Since our work is dealing with a specific type of fading which is the correlated shadowing, it does not consider any other condition which can degrade the Signal to Noise Ratio (SNR) values. The work is concerned about realization complexity in computation and system overall performance. Some analytical assumptions are made hoping that the results will provide awareness for further works in MHCRN under more realistic assumptions. The scope of the work is not to develop an algorithm of path selection but implementing a multi-hop architecture based on a fuzzy logic user selection system.

## 1.6 Structure of the thesis

The thesis is structured in five chapters. The study is introduced in the first Chapter. The second Chapter summarizes the theoretical state of the art on cognitive radio and fuzzy logic. Further in the same chapter, works related to the topic are presented through existing implementation of multi-hop cognitive radio networks under correlated shadowing based on fuzzy logic. Chapter three describes thoroughly the system and how it operates. The first section is about the smart user selection based on fuzzy logic and the second section on the other hand, provides details about detection system optimization. The fourth Chapter presents widely our results and discussions are carried on them. The study is concluded in Chapter five and potential future works addressed.

## 1.7 Note on publication

Willy M. Attikey, Peter Kihato, Vitalice Oduol, Fuzzy Logic Based Smart User Selection for Spectrum Sensing under Spatially Correlated Shadowing, *Journal of Sustainable Research in Engineering, Volume 3, No 2 (2016)*

[Available at <http://sri.jkuat.ac.ke/ojs/index.php/sri/index>]

# Chapter 2

## Literature review

In this chapter, we provide an overview of MHCRN and fuzzy logic theory. We particularly emphasize on works related to correlated shadowing as well as optimization of cluster-based cooperative spectrum sensing in MHCRN using fuzzy logic.

In Section 2.1 we discuss the main characteristics of the CRN. This is followed by a review of fuzzy logic aspects and its applications in CRN in sections 2.2 and 2.3.

### 2.1 Cognitive Radio Network

Wireless based applications are increasing exponentially, which makes spectrum more and more scarce. Systems providers, national regulatory bodies and international institutions are more concerned with this. Spectrum is a shared resource between different types of services and it has been, up to date, inefficiently utilized either spatially or temporally. These challenges prompted recent technologies to efficiently tackle spectrum rarity.

#### 2.1.1 Definition of cognitive radio

According to International Telecommunication Union (ITU), Cognitive Radio System (CRS) is defined as : "A radio system employing technology that allows the system to obtain knowledge of its operational and geographical environment, established policies and its internal state; to dynamically and autonomously adjust its operational parameters and protocols according to its obtained knowledge in order to achieve predefined objectives; and to learn from the results obtained"[8]. Haykin [9] defines Cognitive Radio (CR) as a smart wireless communication system that is aware of its surrounding environment, learns from the

environment and adapts its internal states to statistical variations in the incoming RF stimuli by making matching changes in certain operating parameters in real time. Joseph Mitola III was the first to use the term cognitive radio in [10]. He defined it as a radio driven by a large store of a priori knowledge, searching out intelligent ways to provide the facility the users want. Based on the previous definitions we can notice that cognitive radio has two principal characteristics such as:

- highly reliable communications whenever and wherever needed;
- efficient utilization of the radio spectrum.

The concept of cognitive radio is to detect a spectrum hole known also as white space, which is a band of frequencies allocated to a primary user, but not utilized at a particular time and specific geographic location by that user. Spectrum utilization can be improved significantly by making it possible for a secondary user (who is not being serviced) to access a spectrum hole unoccupied by the primary user at the right location [11]. Figure 2.1[11] depicts the dynamic and efficient usage of spectrum whereby when the primary user(PU), also known as licensed user, wants to use a certain band, the cognitive radio leaves to another white space to avoid interfering with the PU.

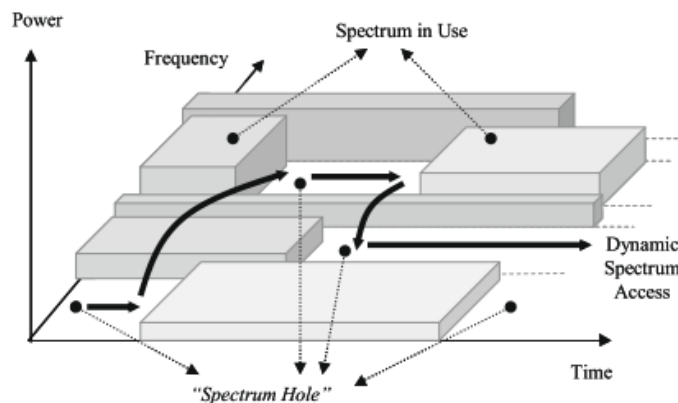

Figure 2.1: Spectrum hole concept

The basic cognitive cycle is shown in Figure 2.2[11] and the corresponding spectrum management functionalities are spectrum sensing, spectrum decision,

spectrum mobility and spectrum sharing [11].

**Spectrum sensing:** Detecting unused spectrum and sharing the spectrum without harmful interference with other users.

**Spectrum decision:** Capturing the best available spectrum to meet user communication requirements.

**Spectrum mobility:** Maintaining seamless communication requirements during the transition to better spectrum.

**Spectrum sharing:** Providing the fair spectrum scheduling method among coexisting CR users. We will further detail the spectrum sensing functionality.

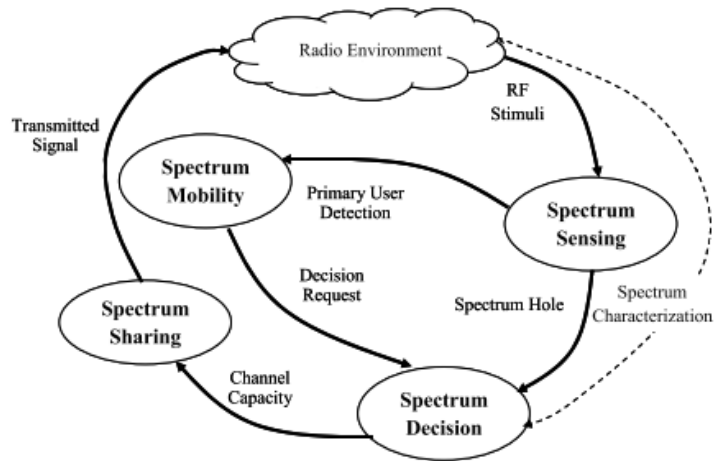

Figure 2.2: Cognitive radio cycle

### 2.1.2 Spectrum sensing

Spectrum sensing is the feature of a CR to detect unused spectrum and share it with its peers without causing harmful interference to the licensed user. In a nutshell, the cognitive radio is able to measure the electromagnetic activities due to the current radio transmissions over different spectrum bands and to capture the parameters related to such bands[12].

A cognitive radio should take real-time decisions about which bands of frequency to sense, when, and for how long. To achieve accurate conclusions regarding the radio environment, the cognitive radio must have enough information on

the sensed spectrum. Moreover, spectrum sensing has to be fast enough to cope with the temporal changes in radio environment. Spectrum sensing falls in two categories of architecture: centralized and distributed[2]. In the centralized spectrum sensing, a base station senses the target frequency band, and the outcome is shared with other nodes in the system. In distributed spectrum sensing, the cognitive users do not cooperate which means that each CR user will individually detect the channel, and in case one CR detects the primary user it will vacate the channel without informing the other users(distributed uncoordinated) or the cognitive users build up a network without the need of a base station(distributed coordinated)[13]. Spectrum sensing is basically measured using two parameters: *Probability of Detection (PD)* and *Probability of False alarm (PF)*. Spectrum sensing techniques are broadly classified in three groups:

- *Transmitter detection or non-cooperative sensing:* It is based on the ability of CR users to detect that a primary user is transmitting. A hypothesized model is derived for transmitter detection in [14, 15] that is:

$$\begin{aligned}
 y(k) &= n(k) \dots \dots \dots H_0 \\
 y(k) &= h(k) * s(k) + n(k) \dots \dots \dots H_1
 \end{aligned}
 \tag{2.1}$$

$H_0$  : primary user is absent

$H_1$  : primary user is present

where  $y(k)$  is the received signal by the SU,  $h(k)$  is the channel gain of the sensing channel between the PU and the SU,  $s(k)$  is the signal sent by the PU,  $n(k)$  is the Additive White Gaussian Noise (AWGN) with zero mean and variance  $\sigma_n^2$ . This technique comprises several approaches such as energy based detection, matched filter (MF) based detection, cyclostationary based detection which are the most common.

- Energy detection is a spectrum sensing method that detects the presence or absence of a primary user just by measuring the received signal power[16]. The most often used approaches in the energy detection are based on the Neyman-Pearson (NP) lemma whereby the probability of

detection is increased for a given probability of false alarm[17]. Figure 2.3[13] shows the block diagram for the energy detection technique. The signal is first passed through a band pass filter of  $W$  bandwidth and is integrated over time interval. The integrator output is then compared to a predefined threshold. The existence of a primary user is concluded if the output is greater than the threshold and the absence otherwise. Though energy detection is not optimal, it is widely

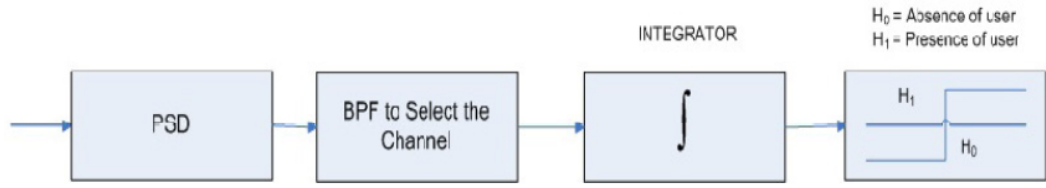

Figure 2.3: Energy detection

used due to its simplicity and no requirement on a priori information of the primary user.

- The matched filter detector[18, 19] was first proposed in [20]. The matched filter (also referred to as coherent detector), can be considered as a best sensing technique if CR has a priori knowledge of PU signal[17]. The block diagram is shown on Figure 2.4[13]. The operation of a matched filter is given by:



Figure 2.4: Matched filter detection

$$Y[n] = \sum_{K=-\infty}^{\infty} h[n - k]x[k] \quad (2.2)$$

Where  $h$  the impulse response that is matched to the reference signal, is convolved with  $x$  the unknown signal for maximizing the SNR.

Matched filter detector uses less detection time and is optimal in stationary Gaussian noise but has the disadvantage that prior knowledge of primary user signal is required.

- Cyclostationary feature detection makes use of the periodicity in the received primary signal (sinusoidal carriers, pulse trains, spreading code, hopping sequences or cyclic prefixes) to detect the presence of PU. Block diagram of cyclostationary feature detection is shown in Figure 2.5 [13]. Even though this technique has better performance than en-

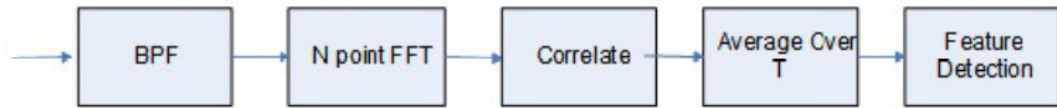

Figure 2.5: Cyclostationary feature detector

ergy detection especially in low SNR regions, and has robustness to noise uncertainties, it suffers from high computational complexity and long sensing time.

- MultiTaper based Estimation is a method developed by David J. Thomson. It consists of a set of optimal band pass filters instead of rectangular windows as in periodogram. MultiTaper based Estimation basically uses orthonormal tapers to generate a single spectrum estimate with less spectral leakage and good variance.

Figure 2.6 [21] describes the steps to calculate MultiTaper based Estimation as follows:

- i) Collect the sample data of the input.
- ii) Calculate the product of the data samples with taper coefficients to get tapered data samples.
- iii) Produce the eigen spectrum by computing the Fourier transform for each of the tapered data samples and by squaring each of the resulted data
- iv) Join all the eigen spectrum to obtain a single spectrum estimate.



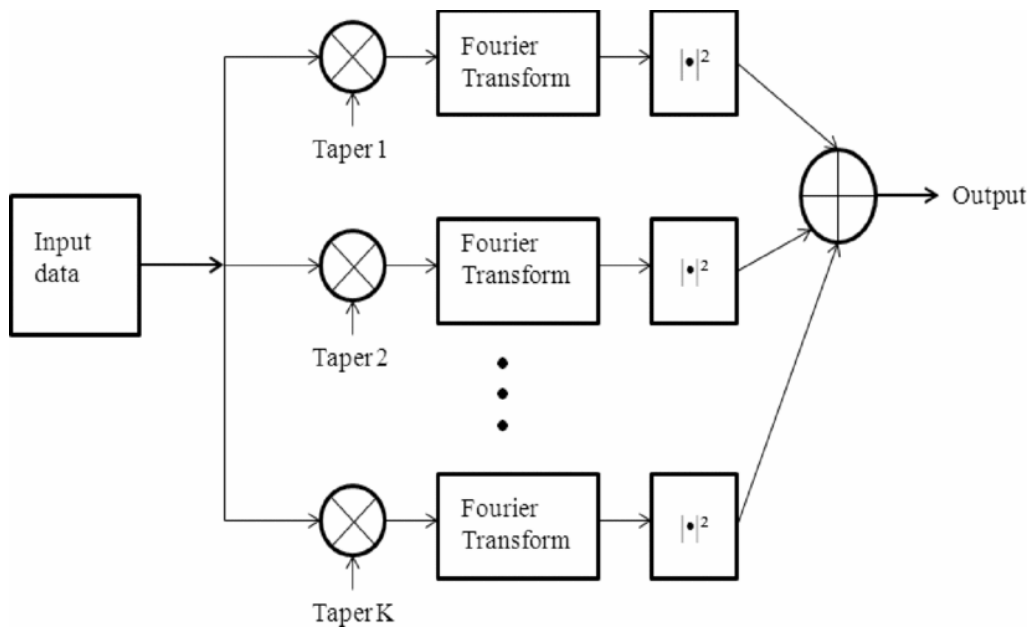

Figure 2.6: Multitaper spectral estimation block diagram

This spectral estimation method can use two different types of tapers which are:

- \* MultiTaper based Estimation uses orthonormal slepian tapers. The tapers concentrate the maximum energy in the bandwidth  $[-W, W]$  and rejects as much as possible out of band energy.
- \* Sinusoidal tapers are orthogonal tapers used for the estimation. Here, the number of tapers required increases with the frequency band.

When the number of tapers is high, slepian MultiTaper based Estimation introduces bias unlike the sinusoidal MultiTaper based Estimation.

- Filter bank based spectrum estimation (FBSE) is considered as the simplified version of MultiTaper based Estimation. It uses only one prototype filter for each band. FBSE is based on the same concept of maximal energy concentration in the bandwidth  $[-W, +W]$ . MTSE is better for small samples whereas FBSE is better for large number of samples[13].

- Covariance based Detection does not require any knowledge of noise and signal power for the choice of the detection threshold thus its ability to avoid noise effect caused by uncertainty. It uses space-time signal correlation for signal detection[22]. The covariances of signal and noise are generally different and that is how this method is able to differentiate the primary user signal from background noise

Figure 2.7[13] compares different detection techniques of spectrum sensing. As we can notice, implementation of matched filter based detection is complex, but provides the highest accuracy. On the contrary, the energy based detection is the easiest to implement and least accurate compared to other approaches. In between the two previous techniques, are the others with balanced complexity and accuracy.

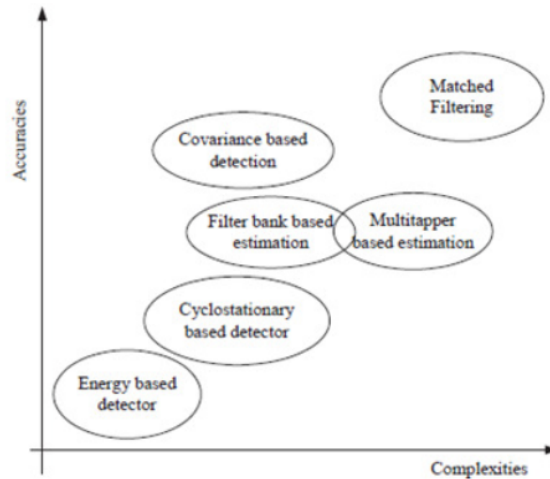

Figure 2.7: Sensing accuracy and complexity of various sensing methods

Figure 2.8[23] shows all the aspects related to spectrum sensing including the challenges, the different sensing techniques and the architectures among others. Two of these sensing techniques are described below:

- Cooperative detection: It refers to spectrum sensing methods where information from multiple cognitive users is included for primary user detection.
- Interference based detection: It refers to spectrum sensing methods where

CR users operate in Ultra Wide Band (UWB). This technique includes the primary receiver detection and the interference temperature management [24].

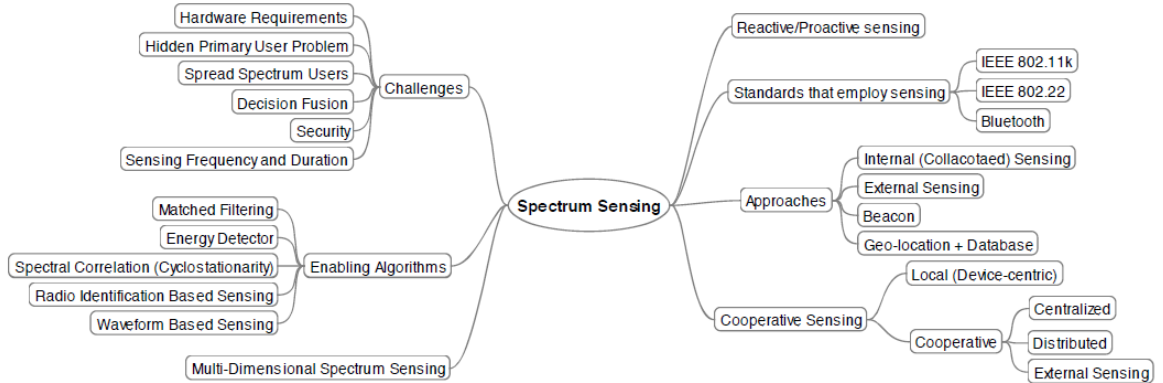

Figure 2.8: Various aspects of spectrum sensing for cognitive radio

### 2.1.3 Cooperative spectrum sensing

Cooperative spectrum sensing takes place when a group or network of CRs share the sense information to decide accurately about the presence or absence of PU. In Cognitive Radio Network, cooperative spectrum sensing has a key role in the detection by improving sensing performance especially in the fading, shadowing and noise uncertainty [25][26]. Several research works have proposed different methods to achieve a better spectrum utilization by using cooperative spectrum sensing [27, 28, 29, 30]. However, many publications have shown that high cooperative gain is achieved when cognitive users observations are not made through fading environments which is not realistic [25, 31, 32]. Selecting secondary users optimally for cooperative sensing is important in determining the performance of cooperative sensing since it helps to increase cooperative gain and tackle the overhead challenges [5]. Sensor selection has been extensively studied [33, 34, 35, 36]. The authors in [33] showed that correlated shadowing leads to the overall performance degradation. Furthermore, they pointed out that sufficiently spatially dispersed cooperating nodes experiencing independent fading, can alleviate the effect of the correlated shadowing. They concluded therefore that an ideal user

selection in cooperative spectrum sensing can efficiently increase the system performance as well as its security. In [34, 35], they developed respectively decentralized and centralized user detection schemes to improve sensing performance in cooperative spectrum sensing. The authors in [36] provided a sensor selection algorithm, based on the level of correlation, whereby only the less correlated users collaborate to sense the primary frequency. In [35], they provided three different algorithms to perform optimal centralized user detection. The sensor selection algorithms partition in active and passive sets, the nodes which have been selected from the total number of nodes as being able to perform sensing. Based on an appropriate compromise between energy consumption and sensing performance, the active set is comprised of nodes which will cooperate in sensing at a certain time. The first algorithm is an integer optimization problem based on correlation measure by using knowledge on the location of the sensors and the corresponding uncertainty to form an active set. The second algorithm is based on estimation of location of cooperating sensor nodes and the decorrelation distance to find an optimal uncorrelated nodes. The last algorithm, is based on radius knowledge, that is the distance between the remaining nodes and the ones chosen for cooperation. When large number of CRs are involved in cooperative detection, centralized user selection suffer from prohibitively large control channel bandwidth and much increased reporting delay [7].

Though conventional cooperative spectrum sensing brought a better reliable sensing, it can suffer, among others, from performance degradation due to flawed reporting channels. Clustering is a technique which solves the previously cited shortcoming and bring various advantages compared to the the conventional cooperation[37]. Several publications have widely studied clustering in spectrum sensing[4, 34, 38]. Malady et al. in [4] investigated four clustering approaches for distributed cooperative spectrum sensing. Firstly, *random clustering* in which the knowledge about the location of both CRs and PUs are not available and each cluster has the same number of CRs. Secondly, *reference-based clustering* whereby clusters are formed according to their positions with regards to a certain reference. Thirdly, *statistical clustering* where the nodes are clustered using a sta-

tistical method based on their relative vicinities. Lastly, *distance-based clustering* in which the locations of CRs and PUS as well are known and only the  $k$  closest users to the PU, out of the  $K$  CR users, participate in the distributed spectrum sensing cooperation. In [39], the authors studied the impact of the trade off, between the probability of detection of the PU and the cost in terms of false alarm probability, on the sensing performance through cooperative spectrum sensing. They suggested distributed cooperation schemes, modeled as a non-transferable coalitional game (i.e. each user has its particular utility function), through game theory. They derived a distributed algorithm for making autonomous coalitions based on a merge-and-split rule. In [38], to address the energy-efficiency challenge they developed a cluster-and-forward based distributed spectrum sensing scheme. The CR users are dynamically clustered in groups in which the cluster heads (CHs) are selected. To achieve spectrum sensing reliability and low power consumption even in poor Signal-to-Noise Ratio (SNR) conditions, the chosen CH plays the role of fusion center (FC) to collect the sensing results from the nodes and make the final decision.

## 2.2 Fuzzy logic concepts

It is common to cope with uncertainty during real world problem solving. Fuzzy set theory is most applicable when the boundary conditions of the set is not clear, also when the information is incomplete/imprecise and non-linear functions of arbitrary complexity can be effectively and quickly modeled. The idea of fuzzy logic was first introduced by Lotfi Zadeh of the University of California at Berkeley in the mid-1960s. Fuzzy set theory based approaches is most useful when dealing with poorly defined operations/imprecise data; approximation concepts are in consideration; utilizing nonlinear functions of arbitrary complexity. User interactions are more natural when using fuzziness in software engineering. For example, fuzziness in spectrum sensing can result in more intuitive and better PU detection. As another example, spatial correlation between CR users can be fuzzified. Often, correlated shadowing is modeled using a mathematical model

but how it can impact SUs sensing capability and therefore the overall detection system can be fuzzy and that is where a fuzzy membership function can help out. This section will explain the basic notion of fuzzy sets and will discuss fuzzy set operators; it introduces linguistic variables, fuzzy logic and approximate reasoning; and it shows applications of fuzzy sets in cognitive radio networks.

### 2.2.1 Fuzzy sets

A fuzzy set is a set without distinct or sharp (crisp) boundaries or without full membership characteristics[40]. In a fuzzy set, it is possible for an element to partially belong to the set unlike in a crisp set where each element either belongs or not to the set. The definition of a fuzzy set is expressed by the characteristic function also known as the membership function[41]:

$$\mu_F : U \longrightarrow [0, 1] \quad (2.3)$$

The degree to which an element belongs to a fuzzy set is called *degree of membership*. For example, considering the membership function  $\mu_{F_{hot}}$ , the human opinion can judge  $37^\circ C$  as fairly hot and  $38^\circ C$  as hot but not as hot as  $40^\circ C$  and higher. Figure 2.9[41] represents this process of partial and full membership of the function  $\mu_{F_{hot}}$ . The *universe of discourse* is a set  $U$  which contains every set of interest for specific problems. Elements of the universe are noted  $u$ .

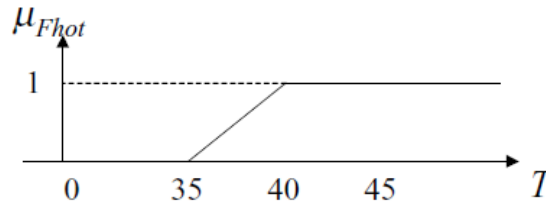

Figure 2.9: The Membership Function  $\mu_{F_{hot}}$

A fuzzy set  $F$  can also be expressed as:

$$F = \{(x, \mu_F(x)) | (x) x \in U\} \quad (2.4)$$

Where  $F$  is the fuzzy set,  $(x, \mu_F(x)|(x))$  is the membership function and  $U$  is the universe of discourse. For discrete  $U$ ,  $F$  is given by:

$$F = \mu_F(x_1)/(x_1) + \mu_F(x_2)/(x_2) + \dots + \mu_F(x_n)/(x_n) = \sum \mu_F(x_i)/(x_i) \quad (2.5)$$

and for continuous  $U$  by:

$$F = \int_U \mu_F(x)/(x) \quad (2.6)$$

## 2.2.2 Fuzzy membership functions

In fuzzy logic, four types of Membership Function (MF) are usually considered. There are: triangular, trapezoidal, Gaussian and generalized bell functions.

### Triangular MF

A triangular MF is defined by three parameters(a,b,c) as follows:

$$triangle(x; a, b, c) = \begin{cases} 0, & x \leq a. \\ \frac{x-a}{b-a}, & a \leq x \leq b. \\ \frac{c-x}{c-b}, & b \leq x \leq c. \\ 0, & c \leq x. \end{cases} \quad (2.7)$$

The parameters  $a$ ,  $b$ ,  $c$  (with  $a < b < c$ ) define the  $x$  coordinates of the three edges of the triangular MF. Figure 2.10(a) shows a triangular MF for triangle ( $x$ ; 20, 60, 80).

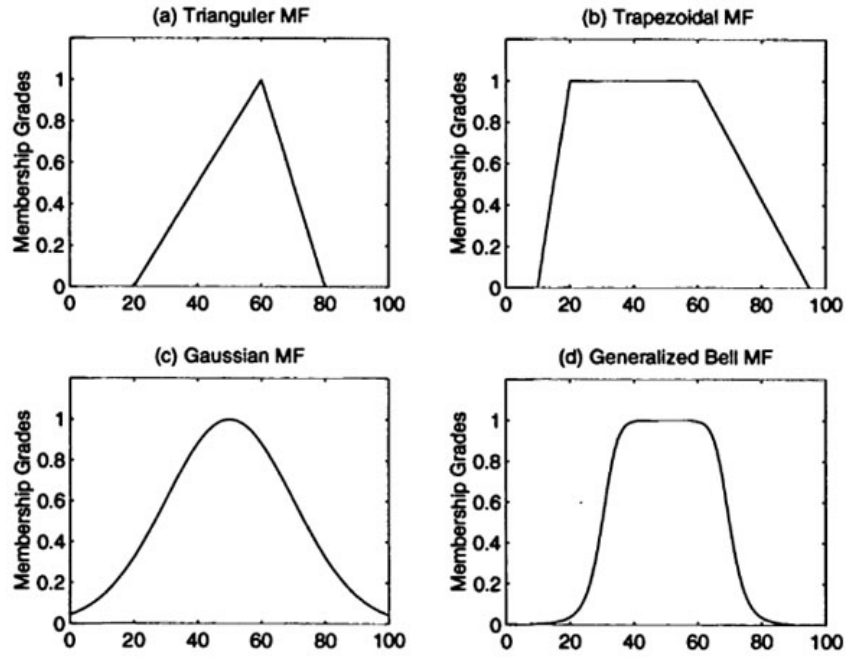

Figure 2.10: Different Membership Functions: (a) triangle, (b) trapezoid, (c) Gaussian, (d) bell

### Trapezoidal MF

A trapezoidal MF is defined by four parameters(a,b,c,d) as follows:

$$trapezoid(x; a, b, c, d) = \begin{cases} 0, & x \leq a. \\ \frac{x - a}{b - a}, & a \leq x \leq b. \\ 1, & b \leq x \leq c. \\ \frac{d - x}{d - c}, & c \leq x \leq d. \\ 0, & d \leq x. \end{cases} \quad (2.8)$$

The parameters a, b, c, d (with  $a < b \leq c < d$ ) define the x coordinates of the four edges of the trapezoidal MF. Figure 2.10(b) shows a trapezoidal MF for trapezoid (x; 10, 20, 60 95).



## Gaussian MF

A Gaussian MF is defined by two parameters( $c$  and  $\sigma$ ):

$$gaussian(x; c, \sigma) = e^{-\frac{1}{2}\left(\frac{x-c}{\sigma}\right)^2} \quad (2.9)$$

In a Gaussian MF,  $c$  and  $\sigma$  represent the MF centre and the MF width respectively. Figure 2.10[42](c) plots a Gaussian MF for Gaussian( $x$ ; 50, 100). Figure 2.10 provides different membership functions for the following values: (a) triangle ( $x$ ; 20, 60, 80); (b) trapezoid ( $x$ ; 10, 20, 60, 95); (c) Gaussian ( $x$ ; 50, 100); (d) bell ( $x$ ; 20, 4, 50).

## Generalized Bell MF

A generalized bell MF (or Bell-shaped Function) is defined by three parameters  $a$ ,  $b$ ,  $c$ :

$$bell(x; a, b, c) = \frac{1}{1 + \left|\frac{x-c}{a}\right|^{2b}} \quad (2.10)$$

The parameter  $b$  is usually positive otherwise it results in an upside-down bell MF. Because of their smoothness and concise notation, Gaussian and bell MFs are becoming more and more popular for specifying fuzzy sets. The bell MF has one more parameter than the Gaussian MF, so it has one more degree of freedom to adjust the steepness at the crossover points. Although the Gaussian MFs and bell MFs achieve smoothness, they are unable to specify asymmetric MFs, which are important in certain applications[42].

### 2.2.3 Properties of fuzzy sets

#### The support set

The support set is a crisp subset of the universe. Crisp set containing all the elements (in the universe) whose membership grade is greater than 0.

$$S(F) = \{x \in X | \mu_F(x) > 0\} \quad (2.11)$$

#### The width of a fuzzy set F

$$width(F) = max(S(F)) - min(S(F)) \quad (2.12)$$

It is possible to have left and right width for asymmetrical functions.

#### The nucleus of fuzzy set F

It given by:

$$nucleus(F) = \{x \in X | \mu_F(x) = 1\} \quad (2.13)$$

### 2.2.4 Operations on fuzzy sets

The classical fuzzy logic operations are: *intersection*, *union* and *complement*. These operations correspond respectively to their crisp logical counterparts *and*, *or* and *not*. The classical methods advanced by Zadeh to represent intersection and union are the most used.

Let consider two fuzzy sets  $A$  and  $B$  in the same universe  $U$ .

#### Intersection

The intersection of the sets  $A$  and  $B$  is a fuzzy set  $C = A \cap B$  where  $\cap$  is the operator defining the intersection. The characteristic function of the resulting fuzzy set is given by:

$$\mu_{A \cap B}(x) = min[(\mu_A(x), \mu_B(x))] \quad \forall x \in U \quad (2.14)$$

The intersection results in a fuzzy set which contains all the elements that are present simultaneously in sets  $A$  and  $B$ . Figure 2.11[40] depicts the intersection operation of two fuzzy sets.

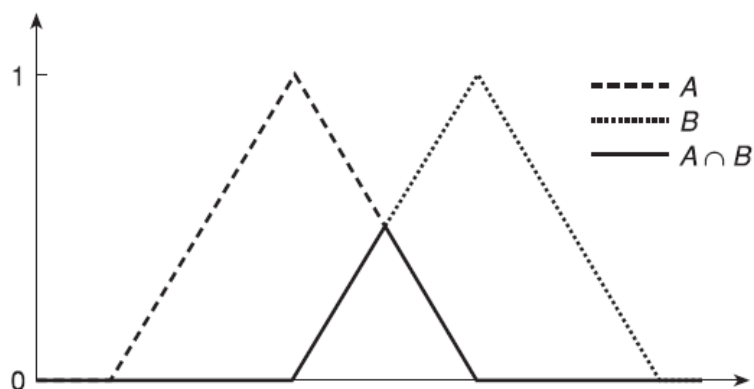

Figure 2.11: Fuzzy-set intersection

## Union

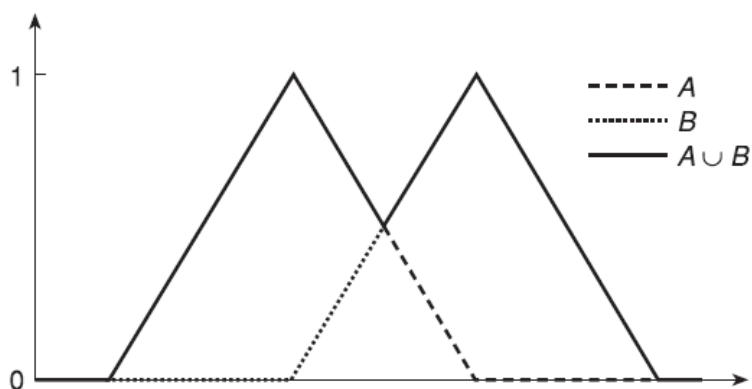

Figure 2.12: Fuzzy-set union

Figure 2.12[40] represents the union fuzzy operator. The union of the sets  $A$  and  $B$  is a set  $C = A \cup B$  where  $\cup$  is the operator defining the union. The resulting fuzzy set  $C$  contains all the elements which reside in each of the sets. The membership function of fuzzy set  $C$  is given by:

$$\mu_{A \cup B}(x) = \max[(\mu_A(x), \mu_B(x))] \quad \forall x \in U \quad (2.15)$$

## Complement(negation, NOT)

Let consider a fuzzy set  $A$  in a universe  $U$ . The complement of  $A$  noted  $\bar{A}$  or  $A'$  is a fuzzy set given by:

$$\mu_{A'}(x) = 1 - \mu_A(x) \quad \forall x \in U \quad (2.16)$$

Representation of the complement operation is shown on Figure 2.13[40].

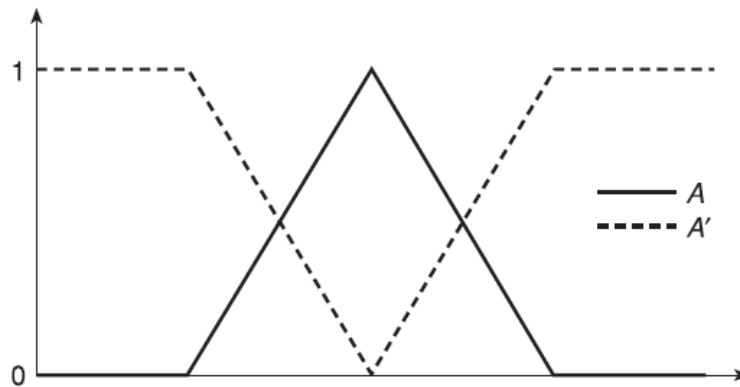

Figure 2.13: Complement

### 2.2.5 Fuzzy system design

There are usually four steps to develop a fuzzy system.

#### i. Fuzzification

It calculates a crisp input degree of membership or converts it in a fuzzy value. It is done through the following steps:

- Definition of the universe of discourse;
- Identification and definition of the linguistic variables(low, moderate, high);
- Definition of the membership functions within the universe of discourse;

- Graphical representation of the membership functions(triangular, trapezoidal, Bell or Gaussian)

ii. Knowledge base

It is a collection of conditional fuzzy *IF-THEN* rules in which the antecedents and the consequents involve linguistic variables. An example of a conditional statement is expressed by: IF x is *big* THEN y is *small*. The general rule structure shown above is commonly known as Zadeh-Mamdani rule. The knowledge base characterizes also a simple relation between the system inputs and outputs.

iii. Inference

The inference process, based on the knowledge base, manipulates the knowledge representation resulted from the fuzzification step. Inference helps to fire the rules by matching fuzzy antecedents against fuzzy facts. There are two types of inference process. The Mamdani[43, 44, 45] approach also termed as MAX-MIN approach is the widely used one. Another popular fuzzy inference model is the Takagi-Sugeno[44, 46] model which appears to be more accurate.

iv. Defuzzification

Defuzzification has the opposite role of fuzzification. It transforms back to crisp values the fuzzy values from the fuzzy system. The two common defuzzification methods are the Center of Gravity (CoG) or CENTROID method and Mean of Maxima (MoM) or MAXIMUM method[47].

In the CoG method, the crisp value of the output variable is computed by finding the variable value of the center of gravity of the membership function for the fuzzy value. This is described by the following equation.

$$CoG(z) = \frac{\int \mu_C(z) \cdot z dz}{\int \mu_C(z) dz} \quad (2.17)$$

In the MoM method, one of the variable values at which the fuzzy subset

has its maximum truth value is chosen as the crisp value for the output variable. There are several variations of the MoM method that differ only in what they do when there is more than one variable value at which this maximum truth value occurs. One of these, the AVERAGE-OF-MAXIMA method[47], returns the average of the variable values at which the maximum truth value occurs.

Architecture of a typical fuzzy logic controller is shown on Figure 2.14.

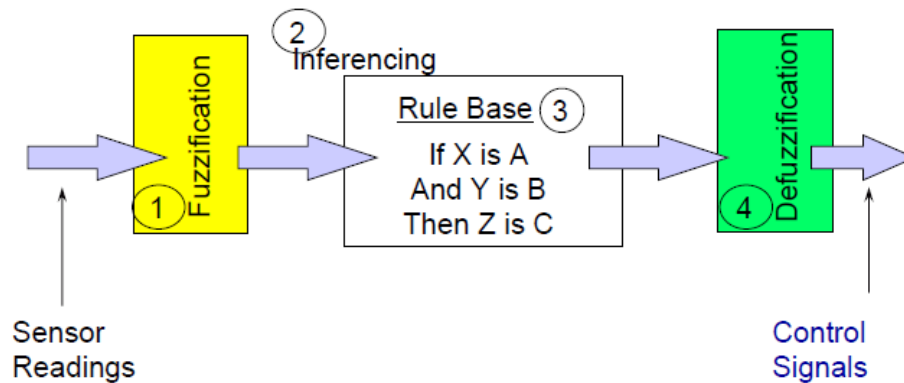

Figure 2.14: Typical fuzzy logic controller architecture

## 2.3 Application of Fuzzy Logic in Cognitive Radio Networks

Fuzzy logic has shown its ability and efficiency to deal with uncertainty. Many works[48, 49, 50, 51] have adopted fuzzy concepts to resolve challenges in Cognitive Radio Network by considering different parameters in order to increase the sensing performance.

In [48], the authors propose a new method using Fuzzy Logic to manage the opportunistic spectrum access problem in CRN. Their fuzzy logic system takes as inputs three descriptors which are: spectrum utilization efficiency of the SU, its degree of mobility, and its distance to the primary user. They derived 27 fuzzy rules for the knowledge base by using the knowledge of 5 network experts. The

output of the system is the probability of a SU to be selected to use an available spectrum band. Their system show a good performance in providing opportunistic access to radio band of frequencies without interfering with the PU but they did not consider a clustering scheme where a centralized base station can coordinate SUs spectrum access. A comparative study is made between Mamdani and Takagi-Sugeno models in [44] by using the same fuzzy logic system previously cited. Their results show that the Takagi-Sugeno model performs slightly better than its Mamdani counterpart because the former offers more accuracy and computational efficiency yet the latter is widely used for its ease of use in model formalization. The authors in [49] developed a fuzzy cooperative decision approach by comparing the performance of the "OR" and the "AND" rules. They introduced two different thresholds to achieve a more reliable decision scheme and derived the detection and the false alarm probabilities by using the "OR" and the "AND" rules. Results showed that their system improved performance over than the conventional sensing approach.

From the above literature, works have been done on uncorrelated users selection either by using distance or correlation coefficient but without combining their methods to fuzzy logic in both cases. Also, they considered conventional energy detection techniques either in a clustering fashion or by taking nodes individually but more practical environment would consider a multi-hop architecture where nodes can relay on each other to forward their observations to the fusion centre. The contribution of this work is to develop two fuzzy-based systems which uses the advantages brought by clustering technique and multi-hop architecture. The first, an user selection system helps to combat spatially correlated shadowing by choosing only uncorrelated users. The second, a detection system helps to senses the spectrum band and to detect accurately any primary user.

# Chapter 3

## Design and Implementation

In this chapter, we detail the methods used to fulfill the objectives listed in the first chapter.

### 3.1 Fuzzy logic

Fuzzy logic provides an approach to resolve a problem based on inaccurate, noisy, and incomplete information. Fuzzy logic uses a set of fuzzy membership functions and knowledge base to achieve the solution that meets objectives desirable.

#### 3.1.1 Spatially correlated shadowing and smart user selection

Cooperative sensing is more effective when cooperating nodes experience independent fading and shadowing[52, 53]. The probability of detection is degraded in correlated shadowing, hence deteriorating the overall sensing performance of MHCRN. In [7], it is shown that when collaborating SUs are located far apart it gives robust defense against fading and shadowing. Therefore, the fundamental challenge to alleviate correlated shadowing is optimally select CR user ensuring that all cooperating CRs experience independent fading and shadowing conditions. Selecting CR users cautiously in CSS enhances the throughput as well as the reliability and security of the overall system and reduces the energy consumption. CR selection, also referred to as user selection, based on centralized and decentralized topologies is discussed in literature [34, 35]. In centralized user selection, Fusion Center (FC) chooses independent CRs which will cooperate based on their location estimation. Gudmundson in [54] was first to develop a mathematical model to express correlated shadowing between two nodes. The model is



given by:

$$R_{ij} = \exp^{-\frac{d_{ij}}{D}} \quad (3.1)$$

where  $R_{ij}$  is the correlation coefficient,  $d_{ij}$  represents distance between any two users and  $D$  is called the decorrelation distance and depends on the environment. His paper shows that correlated shadowing between two CRs is a degrading exponential function of the distance separating radios and hence there exists a decorrelation distance beyond which the cooperating users can be considered to undergo uncorrelated shadowing. Centralized user selection suffers from large control channel bandwidth and high reporting delay for large CRNs[7]. Distributed selection technique results therefore in optimal user selection especially for large networks. Different clustering methods are proposed in [4] based on distributed approach. These clustering techniques, which can be either statistical, random, reference-based or distance-based, are based on the availability of location information of primary and secondary users. Bomfin et al. in their work [55] develop a three-dimensional correlated shadowed channel model based on grid points. From that model, a closed formula is derived to obtain the correlation between any two points of the grid. In [36], an algorithm is developed to select uncorrelated cognitive radios by relying on the correlation experienced by the radios. We based our work on the centralized user selection and to avoid the shortcomings that is brought by large networks we use a relatively small CRN.

### **System model**

Cooperative spectrum sensing can result in cooperative sensing overhead due to reciprocal exchange of massive information among CR users[56]. For the simulations, we use therefore a set of 60 nodes, so that after selection we remain with a fair number of nodes. They are randomly spread on a 150m x 150m field and sense the primary frequency to detect the presence or not of any licensed user as described in the Figure 3.1.

Among the set of 60 nodes, the fuzzy user selection system has selected 27 nodes as uncorrelated to cooperate. From that set of 27 uncorrelated users, we

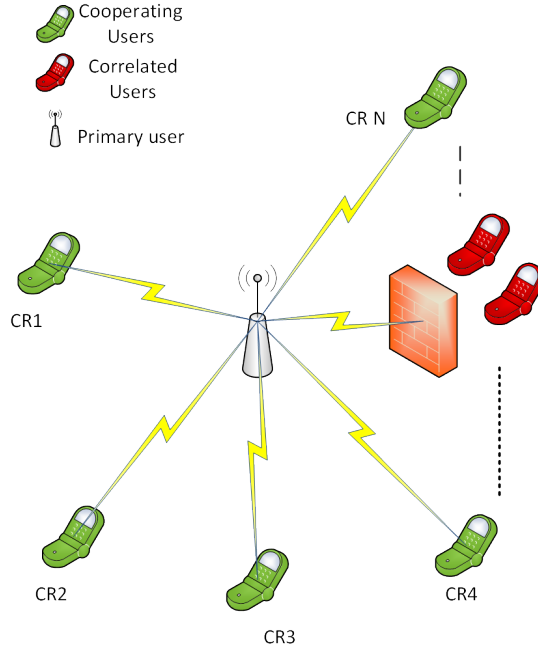

Figure 3.1: Network model for user selection

choose an even number of 24 users so that we can spread them into uniform clusters. Spectrum sensing is done in a centralized fashion by the SUs. Hence the Fusion Centre is aware of the relative distance between cognitive users and the PU by using GPS technology. We adopt two fuzzy logic systems, one to model the spatial correlation and the second to implement the spectrum sensing. At this stage, SUs who will cooperate are selected based on the correlation coefficient which represents the output of the first fuzzy system. There are two inputs for the first fuzzy system which are respectively the distance separating the nodes and the decorrelation distance  $D$ . The latter varies from 30 ~ 100 meters for outdoor systems [57, 58]. Since the decorrelation distance varies in a specific range, we study the cases where  $D$  takes respectively three different values: 30, 65 and 100 meters which represents the minimum, the mean and the maximum values. We selected these values to show better how the system can behave when we use different decorrelation distances and also because for close values the impact is not well distinguished. The crisp values of the correlation coefficient obtained for each input are compared to a threshold  $\epsilon_d = e^{-(D/D)} = e^{-1} = 0.37$  which represents the maximum correlation coefficient, based on Gudmundson's model (equation

3.1) [54], that should not be exceeded. The SUs whose correlation coefficient is above the threshold are considered correlated and will not participate in the CSS. Among the SUs remaining, the 24 least correlated users are selected and their correlation coefficient will be used as input for the second stage. The inputs are generated randomly in the simulation tool(Matlab 2016). Below is the fuzzy system on Figure 3.2 which is used to select less correlated users.

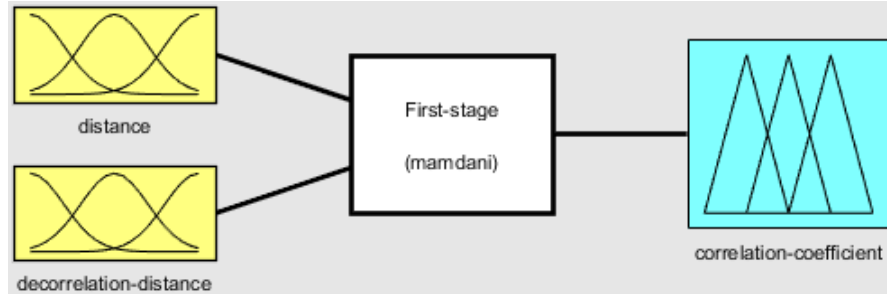

Figure 3.2: Fuzzy based User selection system

## Framework

To apply fuzzy logic to correlated shadowing, we come up with a simple fuzzy system which takes as inputs two parameters and gives one parameter as output as shown on Figure 3.3.

The proposed fuzzy system has two inputs with three membership functions each and one output with five membership functions. The *distance* membership functions are labeled as *close*, *average* and *far* which show how close or far two specific SUs are. The distance is the separation between any two CR users and is given, for  $i^{th}$  and  $p^{th}$  CR users, by:

$$d_{ip} = \sqrt{(x_i - x_p)^2 + (y_i - y_p)^2 + (z_i - z_p)^2} \quad (3.2)$$

Regarding the *decorrelation distance*, the membership functions are labelled as *low*, *medium* and *large*. The names of the membership functions of the *correlation coefficient*, which is the output, are *very low*, *low*, *normal*, *high* and *very high* which indicates how correlated two SUs are. Min-Max is used as the implication and aggregation methods and centroid as defuzzification method[40]. We use

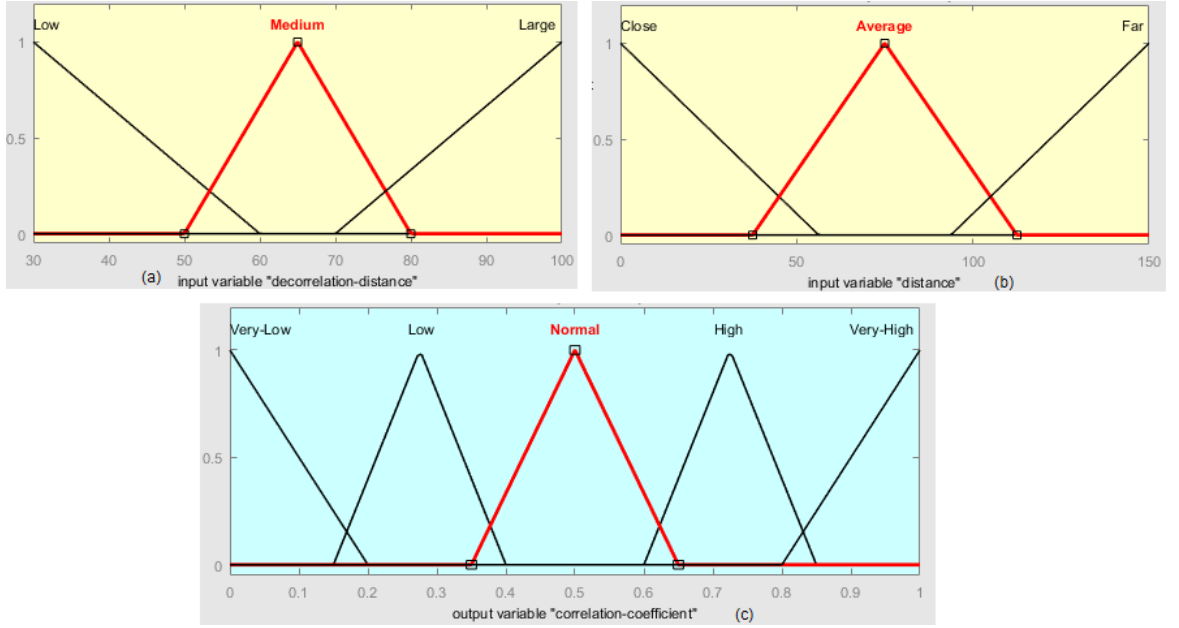

Figure 3.3: Membership functions of the User selection system

triangular membership functions of same shape for both inputs and output. The latter is normalized on a scale of 0 to 1 and compared to a threshold of  $\epsilon_d = e^{-(D/D)} = e^{-1}$ . SUs with a correlation coefficient less than the threshold are said not correlated and correlated otherwise. The knowledge base of the fuzzy system is presented in Table 3.1. There are a total of 9 rules. For example, if the distance input is *average* and the decorrelation distance input is *low* then the combined fuzzy decision is *very low* and that means the nodes on that link are not correlated.

Table 3.1: Rules base for fuzzy based user selection

Input1	Input2	output
close	low	normal
close	medium	high
close	large	very high
average	low	very low
average	medium	low
average	large	normal
far	low	very low
far	medium	low
far	large	normal

## 3.2 Cluster-based Fuzzy Logic CSS

Cooperative spectrum sensing has been shown to be the most efficient spectrum sensing which deals with multipath fading and shadowing[7, 25]. Cooperative spectrum sensing occurs when CR users contribute to sense licensed band and to detect PU[59]. CSS can be classified in 3 types of networks: centralized [25, 60], distributed[61], and relay-assisted which are shown on Figure 3.4[5]. A centralized cooperative spectrum sensing is used in this work. Basically, CSS is comprised of 3 steps such as: *local sensing*, *reporting* and, *information fusion*. .

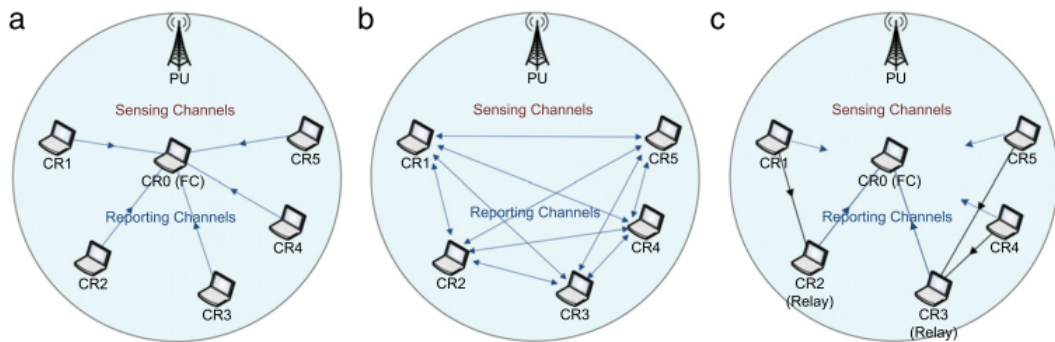

Figure 3.4: Classification of cooperative sensing (a) centralized, (b) distributed, and (c) relay-assisted

### 3.2.1 Local sensing

Prior to the local sensing, uncorrelated CR users selected based on our smart user selection system, are clustered in six uniform clusters of four members each using distance clustering algorithm[4]. Because we are using a centralized CSS architecture, the position knowledge of each node is managed by the FC, and that eases the clustering formation. Selecting uncorrelated users comes to select users separated by a minimum decorrelated distance since correlated shadowing is exponentially related to the distance. Our local sensing is based on a fuzzy detection system instead of the common well-know sensing techniques(energy detection, matched filter detection,etc). The detection performance is assessed by using one important parameter that is the probability of detection  $P_d$ . At

this stage, the correlation coefficients of the 24 least correlated users for the three different decorrelation distances, are collected and combined to signal to noise ratio (SNR) variables as inputs for a spectrum sensing system based on fuzzy logic. Considering  $i^{th}$  SU, the SNR formula is given by

$$SNR_{pi} = |h_{pi}|^2 E_p N_o \quad (3.3)$$

where  $h_{pi}$  is the channel gain between the PU and  $i^{th}$  SU,  $E_p$  is the energy of primary signal and  $N_o$  is the variance of AWGN. As shown on Figure 3.5 the output here is the probability of detection for different values of decorrelation distances.

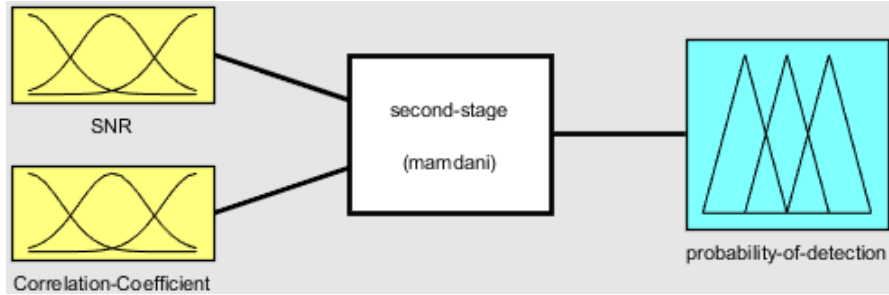

Figure 3.5: Detection system based on Fuzzy logic

To design the fuzzy logic based spectrum sensing system, the twenty four least correlation coefficients of the first fuzzy system are taken as one of the inputs. The second input is the SNR values of each SU which vary from -40 to 30 dB. This range of SNR is used to represent better the behavior of the system in different SNR conditions[50]. The output, the probability of detection varies between 0 to 1.

Both input have five membership functions named as *very weak*, *weak*, *zero*, *high* and *very high* for the SNR and the correlation coefficient input named as in the previous system. The output has also five membership functions labeled *very low*, *low*, *medium*, *high* and *very high*. Figure3.6 represents the different membership functions of detection system based on fuzzy logic. Here, Gaussian membership functions are used for both inputs and the output. We use Gaussian membership functions, because of the smoothness of their slope which supports

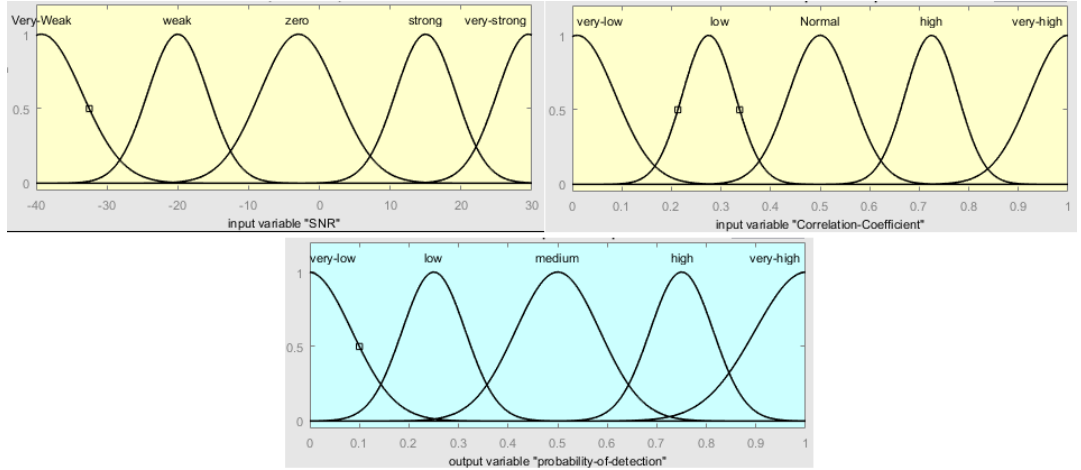

Figure 3.6: Membership functions

more the characteristic of fuzzy logic between two successive ranges. We study with this system the probability of detection with correlation coefficients obtained for 3 different values of decorrelation distance. This will show the impact of correlation between close users on the detection system. Also here Min-Max is used as the implication and aggregation methods and centroid as defuzzification method. Since we do not consider any other fading conditions which can degrade the SNR values, it is assumed therefore, that in condition of low correlation coefficient, the SNR is relatively good. Starting from the same assumption, we just consider 18 rules out of 25 for the knowledge base displayed in Table 3.2. For example the rule *if correlation coefficient is high and SNR is strong, probability is medium* is left aside because when two SUs are correlated, which means there are relatively too closed and are blocked by the same obstacle, their SNR is degraded because of the fading effect and therefore we assume that the SNR could not be *strong* while the correlation coefficient is *high*.

### 3.2.2 Reporting

After being clustered, each node senses its environment and send their local observations to their respective CH which is chosen randomly among the CR users.

Table 3.2: Rules base for fuzzy based spectrum sensing

Input1	Input2	output
very weak	normal	low
very weak	high	very low
very weak	very high	very low
weak	low	very low
weak	normal	very low
weak	high	very low
weak	very high	very low
zero	very low	medium
zero	low	low
zero	normal	low
zero	high	very low
zero	very high	very low
zero	average	low
strong	very low	very high
strong	low	high
strong	normal	medium
very strong	very low	very high
very strong	low	very high
very strong	normal	low

### 3.2.3 Information fusion

The CH of each cluster, according to the information collected from the nodes, make a cluster decision ( i.e. a PU is detected on a certain band or not). This information gathering is made based on a data fusion technique. There are 3 common data fusion techniques namely: *soft combining*, *quantized soft combining* and *hard combining*. In this work, the hard combining technique is used in order to reduce the transmission overhead since CR users after making their local decision send only their one-bit decision to the CH.

Let  $u_i$  be the local decision of SU  $i$ ,  $d$  the decision made per CH and  $D$  the final decision made by the fusion centre.  $u_i$ ,  $d$  and  $D$  are binary variables. A binary "1" represents when a PU is present ( $H_1$ ) and a binary "0" when it is absent ( $H_0$ ). As fusion rule, we will use the *OR-Rule* whereby the fusion center concludes  $H_1$  when there is at least one CR user which transmits "1". It has been proved in [62] that the *OR-Rule* performs better than the majority rule as well as the AND combining rules in different cases of interest. Moreover, the *OR-Rule*



helps to avoid any interference with the PU signal. Therefore, in cooperative spectrum sensing the probability of detection using the *OR-Rule* is given by:

$$Q_d = 1 - \prod_{i=1}^K (1 - P_d^{(i)}) \quad (3.4)$$

where  $P_d^{(i)}$  is the probability of detection of the  $i$ th CR in its local spectrum sensing and  $K$  the number of cooperating SUs. Since we are in a clustered architecture, the probability of detection at the  $j$ th CH is given by:

$$Q_d = 1 - \prod_{i=1}^{U_C} (1 - P_d^{(i)}) \quad (3.5)$$

where  $P_d^{(i)}$  is the probability of detection of the  $i$ th CR in its local spectrum sensing and  $U_C$  the number of SUs in that cluster.

### 3.3 Multi-hop spectrum sensing model

The selected uncorrelated users once clustered, can send their local decisions to their Cluster Head (CH). Figure 3.7 shows the multi-hop clustered topology. We assume that the intra-cluster channel(channel between SUs and their CH) and the inter-cluster channel(channel between different CH and between CHs and the FC) are not prone to communication error. Since all the CHs are not in the same transmission range from the FC, the farthest ones will forward their cluster decisions to any nearest CH and so on till the decisions of all CHs reach the FC which makes a global decision on the presence or not of PU using also the OR fusion rule. We assume that the clusters are arranged in a layered topology and that the CHs only forward their cluster decisions through any other close CH. By assuming we have  $L$  hops in our architecture, the overall sensing performance is given by the probability of detection expressed as follows:

$$Q_D = \frac{1}{2} \left( 1 - \prod_{j=1}^L (1 - 2 \times Q_d^{(j)}) \right) \quad (3.6)$$

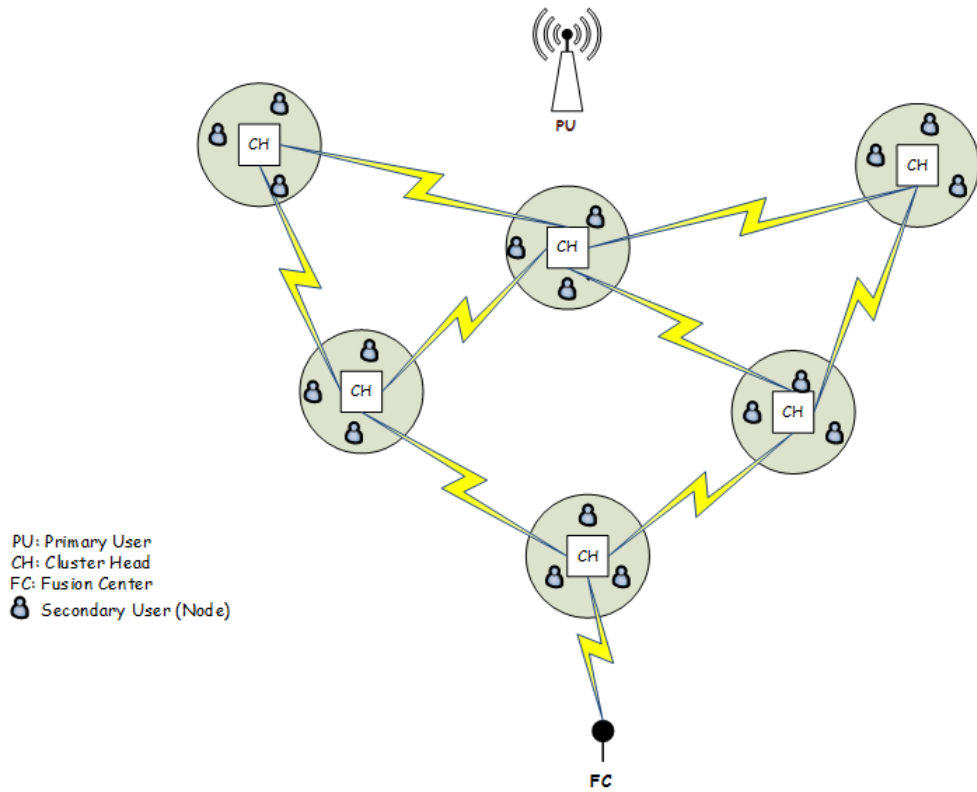

Figure 3.7: Multi-hop architecture model

where  $Q_d^{(j)}$  is the probability of detection of cluster  $j$ . For example, on Figure 3.7 where we have three layers and layer one is by assumption the nearest to the PU, any  $CH_{L1}$  will forward his decision to any CH of layer 2 located in his transmission range which in turn will combine with its own decision, and then forward that combined decision to the last layer CH which repeats the same process. All the decisions combined are received at the FC who takes the final decision.

# Chapter 4

## Results and Discussion

This Chapter aims to provide the different results from the systems developed in this work. We further discuss about how it improves the spectrum sensing mechanism thus the probability of detection by combating correlated shadowing compared to when uncorrelated users are selected based on distance.

### 4.1 Selection of uncorrelated users

Several works have widely studied the degrading impact of correlated users in cooperative spectrum sensing. In our work, we proposed a user selection based on fuzzy logic whereby only uncorrelated SUs are chosen to cooperate. Even though our system seems less aggressive than the distance-based one it remains optimal. As shown on Figure 4.1, the lowest correlation coefficients are obtained when distance separating two nodes is 55 meters and above for a decorrelation distance less than 60 meters because nodes are less likely to be correlated when distance separating them is greater than the decorrelation distance value.

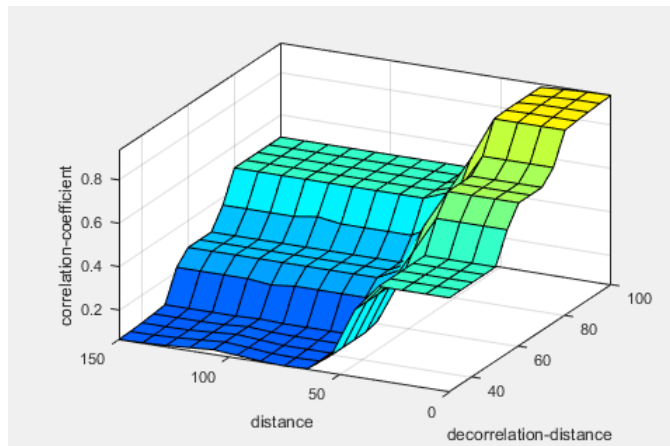

Figure 4.1: Surface plot of the fuzzy based user selection

This portion of the surface represents actually the uncorrelated users since

the correlation coefficient in that region is less than the threshold of  $e^{-1}$ . For the same distance range, the correlation coefficient increases of 25% for the first time when the decorrelation distance varies from 60 meters to 80 meters and for the second time when the decorrelation distance exceeds 80 meters. This can be explained by the fact that when the decorrelation distance is close or greater than the separation distance between any two given nodes, they tend to be correlated. The region of distance less than 50 meters records the highest correlation coefficients which results in highly correlated users. It follows the same growth scheme of 25 % as the decorrelation distance increases and reaches the peak values for decorrelation distance above 80 meters.

## 4.2 Probability of detection based on fuzzy logic

Figure 4.2 depicts the fuzzy based probability of detection in three different cases of the decorrelation distance: 30, 65 and 100 meters. We select these three values to show clearly the importance of the decorrelation distance since too close values will affect only slightly the correlation coefficient hence the detection performance. It is shown on Figure 4.1 how the correlation coefficient only increases around the mentioned values. In this experiment nodes are considered individually in a single hop architecture without being clustered.

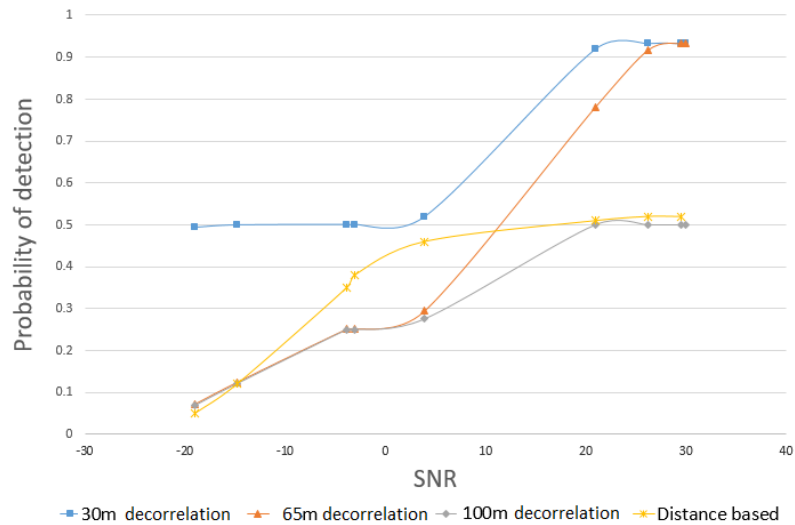

Figure 4.2: Probability of detection of fuzzy logic user selection compared with distanced based selection

Actually, the lowest correlation coefficients are obtained with the 30m decorrelation distance. On the other hand, a decorrelation distance of 100m yields to high correlation coefficient which in turn degrades the probability of detection. This is explained by the fact that when the decorrelation distance is high enough in a case where distance separating SUs is not quite high, SUs tend to experience correlated shadowing. These remarks reflect the fuzzy systems we designed.

We compare our results to the distance-based algorithm since the area of user selection in cooperative spectrum sensing, especially in fighting correlated shadowing, has not been extensively investigated. We can see that our fuzzy based system performs well especially in very low SNR conditions. In the distance-based algorithm, uncorrelated CR users are selected based on the distance separating them and the probability of detection is computed using energy detection technique. Furthermore, our system is able to achieve high detection performance when the decorrelation distance is very low (30 meters) which shows the benefit of nodes being located far from each other at least for a distance equal or greater than the decorrelation distance.

The negative impact of correlated users on the detection system is well shown on Figure 4.3.

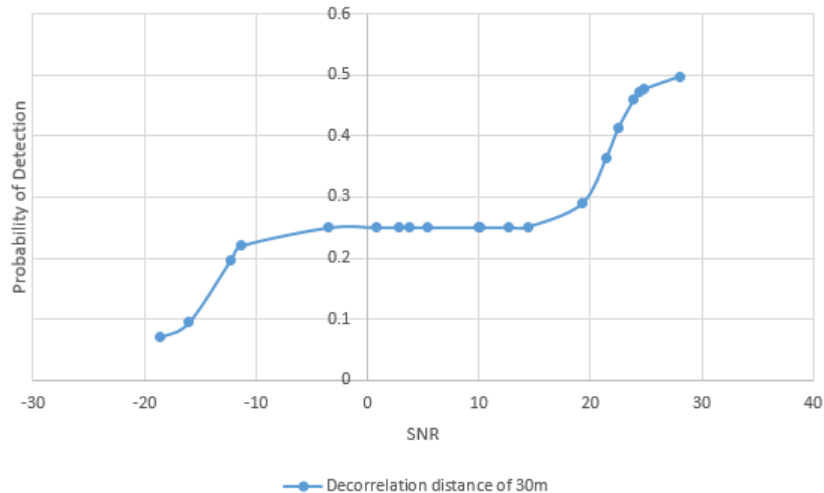

Figure 4.3: Probability of detection of correlated users

Compared to the probability of detection when only uncorrelated users are selected, the probability of detection here reaches only 0.5 in good SNR condition

for the same value of 30m as decorrelation distance. This shows better the gain achieved by selecting first only uncorrelated users to cooperate.

### 4.3 Cluster-based CSS

The results on Figure 4.4 show the gain achieved when using clustering technique to make a final decision. This cooperative gain is clearly noticed when decorrelation distance is equal to 30 meters. For this decorrelation distance, us-

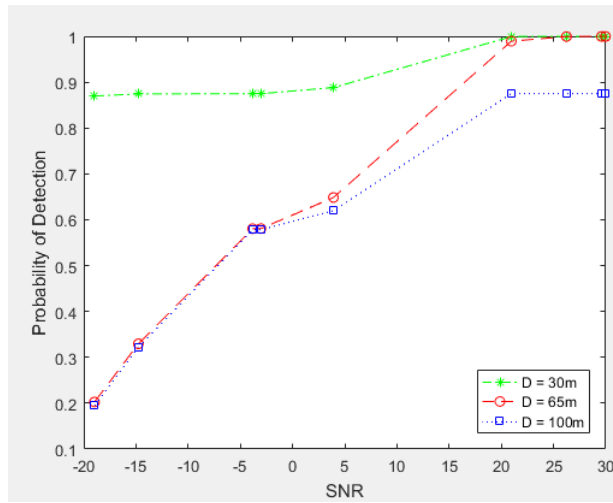

Figure 4.4: Cluster-based CSS probability of detection for different decorrelation distances

ing clustering technique the probability of detection increases of 45% in the region of low SNR (less than 0dB). The same improvement is noticed for high SNR values and the probability of detection reaches its maximum value when SNR is beyond 20 dB by gaining a 10% improvement. For SNR values less than 0dB, the probability of detection increases of 10% when decorrelation distances are 65m and 100m. Then, for 65m as decorrelation distance, the detection performance increases of 45% for SNR=[5dB,20dB] and reaches the maximum value after 20 dB while for 100m as decorrelation distance, the detection performance increases of 40% and remains at 0.85 for the highest SNR values.

The multi-hop architecture also introduces an improvement in the detection performance which is represented on Figure 4.5. Here when the decorrelation distance is of 30m, the detection performance increases of 10% and reaches and

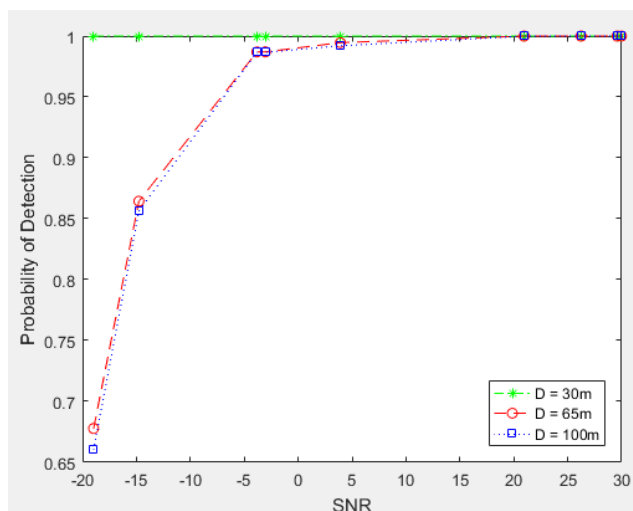

Figure 4.5: Multi-hop Probability of detection for different decorrelation distance

remains at the maximum value throughout the range of study of the SNR. The probability of detection when decorrelation distance are 65m and 100m show the same improvement here. A 45% gain is achieved from -20dB to -15dB and an average gain of 25% is achieved from -15dB up to 5dB. From 5dB, the detection performance increases slightly, reaches its maximum value from 10dB and remains there. By using the fusion rule OR we ensure that no harmful interference is caused to the PU, hence our system reaches better detection performance. The detection performance is degraded for decorrelation distances 65 meters and 100 meters since it leads to more correlated users because of the network size we considered(150m x 150m). This means since the decorrelation distance is higher (half of network size and above) and the SUs are randomly spread over the network, most of inter-users distances are short.

In summary, high detection performance is noticed especially in the region of good SNR conditions regardless of the decorrelation distance or the network topology. Also, multi-hop architecture achieves higher gain than when only clustering is used which in turn achieves higher gain than when nodes are considered individually. This is shown in Figures 4.2, 4.4, and 4.5. The clustering scheme achieves better than individual nodes because CR users observations are first gathered by the CH which makes a final decision. It helps to overcome the biased observations of some nodes. Multi-hop architecture achieves better than

the clustering because each CH after making a decision from its cluster members observations, forwards it to the nearest CH so and so till it reaches the FC who makes the final decision. By being forwarded from CH to CH information are less likely to be biased and it results in an accurate and high detection performance.



# Chapter 5

## Conclusions and Future work

### 5.1 Conclusion

One of the objectives of cooperative spectrum sensing is to deal with the multi-hidden node problem. However, SUs in CSS can suffer from spatially correlated shadowing which will drastically degrade the detection performance. To resolve the cooperative overhead brought by CSS in MHCRN, we based our detection method on clustering technique and on fuzzy logic. The contribution of our work is two-fold.

- 1) Firstly, we presented a fuzzy-based user selection scheme whereby only uncorrelated users are selected to cooperate. It has been shown that selecting uncorrelated cognitive users rather than correlated users can result in better sensing performance. For instance, when the decorrelation distance is 30 meters our system provides a performance which is actually double the one when correlated users are selected. Also, our approach has demonstrated to be accurate enough by selecting the least correlated users specifically SUs between which the correlation coefficient was less than the threshold of  $e^{-1} = 0.368$ .
- 2) Secondly, we developed a spectrum sensing technique which shows its performance by exhibiting good probability of detection. This spectrum sensing technique is based on fuzzy logic and considers two parameters which are the correlation coefficient and the SNR. We analyzed it in different cases of decorrelation distance to show how correlated users can affect the detection of primary user in a Multi-Hop Cognitive Radio Network. By selecting uncorrelated users only to cooperate, the developed fuzzy-based system is able to achieve 40% gain compared to the detection system when the nodes

are selected based on distance. In addition, using a clustering technique in a multi-hop architecture resulted in a detection performance as high as 0.9 to 1 when decorrelation distance is 30m and 0.65 to 1 when decorrelation distance is 65m and 100m. We can recommend for good detection performance, the decorrelation distance should be set regarding the size of the network. In a nutshell, the higher the size of the network, the higher the decorrelation distance and inversely. But by implementing the network, we have to ensure that nodes are located from each other at a distance greater or equal to the chosen decorrelation distance.

## 5.2 Future work

In our study, we consider only spatially correlated shadowing which is not the only type of fading in practical situations. Therefore, future work can take into consideration different fading conditions to simulate a more practical environment. In addition, more parameters such as probability of false alarm can be considered. Finally, more intelligence can be added to the system by using suitable artificial intelligence so that the system gets the ability to learn and adapt itself to the network topology, size, and location of nodes among others.

# References

- [1] U. F. C. Commission *et al.*, “Spectrum policy task force report, et docket no. 02-135, nov. 2002.”
- [2] G. Ghosh, P. Das, and S. Chatterjee, “A Cognitive Radio And Dynamic Spectrum Access - A Study,” *International Journal of Next-Generation Networks*, vol. 6, no. 1, pp. 43–60, 2014.
- [3] J. Mitola III, *Cognitive Radio — An Integrated Agent Architecture for Software Defined Radio*. PhD thesis, Royal Institute of Technology (KTH), Sweden, 2000.
- [4] A. C. Malady and C. R. da Silva, “Clustering methods for distributed spectrum sensing in cognitive radio systems,” in *Military Communications Conference, 2008. MILCOM 2008. IEEE*, pp. 1–5, IEEE, 2008.
- [5] I. F. Akyildiz, B. F. Lo, and R. Balakrishnan, “Cooperative spectrum sensing in cognitive radio networks: A survey,” *Physical Communication*, vol. 4, no. 1, pp. 40–62, 2011.
- [6] B. Khaled, B. Letaief, and W. Zhang, “Cooperative Communications for Cognitive Radio Networks,” *Proceedings of the IEEE*, vol. 97, no. 5, pp. 218–225, 2009.
- [7] R. Umar and A. U. H. Sheikh, “A comparative study of spectrum awareness techniques for cognitive radio oriented wireless networks,” *Physical Communication*, vol. 9, pp. 148–170, 2013.
- [8] I. R. Sector, “Definitions of software defined radio (sdr) and cognitive radio system (crs) report,” *ITU-R SM*, vol. 2152, 2009.
- [9] S. Haykin, “Cognitive radio: brain-empowered wireless communications,” *IEEE journal on selected areas in communications*, vol. 23, no. 2, pp. 201–220, 2005.

- [10] J. Mitola and G. Q. Maguire, “Cognitive radio: making software radios more personal,” *IEEE personal communications*, vol. 6, no. 4, pp. 13–18, 1999.
- [11] M. Iournals, “Relay based cooperation for cognitive radio networks,” *Int. J. Syst. Signal Controlling. Appl.*, vol. 4, no. 1, pp. 1–9, 2011.
- [12] A. Khattab, D. Perkins, and M. Bayoumi, *Cognitive radio networks: from theory to practice*. Springer Science & Business Media, 2012.
- [13] M. Subhedar and G. Birajdar, “Spectrum Sensing Techniques in Cognitive Radio Networks: A Survey,” *International Journal of Next-Generation Networks*, vol. 3, no. 2, pp. 37–51, 2011.
- [14] I. F. Akyildiz, W.-Y. Lee, M. C. Vuran, and S. Mohanty, “Next generation/dynamic spectrum access/cognitive radio wireless networks: a survey,” *Computer networks*, vol. 50, no. 13, pp. 2127–2159, 2006.
- [15] A. Mate, K.-H. Lee, and I.-T. Lu, “Spectrum sensing based on time covariance matrix using gnu radio and usrp for cognitive radio,” in *Systems, Applications and Technology Conference (LISAT), 2011 IEEE Long Island*, pp. 1–6, IEEE, 2011.
- [16] H. Urkowitz, “Energy detection of unknown deterministic signals,” *Proceedings of the IEEE*, vol. 55, no. 4, pp. 523–531, 1967.
- [17] M. A. Abdulsattar and Z. A. Hussein, “Energy detection technique for spectrum sensing in cognitive radio: a survey,” *International Journal of Computer Networks & Communications*, vol. 4, no. 5, p. 223, 2012.
- [18] B. Benmammar, A. Amraoui, and F. Krief, “A survey on dynamic spectrum access techniques in cognitive radio networks,” *International Journal of Communication Networks and Information Security*, vol. 5, no. 4, pp. 68–79, 2013.
- [19] S. Ziafat, W. Ejaz, and H. Jamal, “Spectrum sensing techniques for cognitive radio networks: Performance analysis,” in *Intelligent Radio for Future*

- Personal Terminals (IMWS-IRFPT), 2011 IEEE MTT-S International Microwave Workshop Series on*, pp. 1–4, IEEE, 2011.
- [20] A. Sahai, N. Hoven, and R. Tandra, “Some fundamental limits in cognitive radio,” *Allerton Conference on Communication, Control, and Computing*, vol. 11, no. 4, p. 223, 2004.
- [21] P. S. Reddy and P. Palanisamy, “Multitaper spectrum sensing using sinusoidal tapers with overlapping time series,” in *Control, Instrumentation, Communication and Computational Technologies (ICCICCT), 2014 International Conference on*, pp. 862–865, IEEE, 2014.
- [22] T. S. Dhope and D. Simunic, “Performance analysis of covariance based detection in cognitive radio,” in *MIPRO, 2012 Proceedings of the 35th International Convention*, pp. 737–742, IEEE, 2012.
- [23] T. Yucek and H. Arslan, “A survey of spectrum sensing algorithms for cognitive radio applications,” *IEEE communications surveys & tutorials*, vol. 11, no. 1, pp. 116–130, 2009.
- [24] L. Thanayankizil and A. Kailas, “Spectrum sensing techniques(ii): receiver detection and interference management.” [http://aravind.kailas.googlepages.com/ece\\_8863\\_report.pdf](http://aravind.kailas.googlepages.com/ece_8863_report.pdf), 2008. Accessed:2016-04-07.
- [25] A. Ghasemi and E. S. Sousa, “Collaborative spectrum sensing for opportunistic access in fading environments,” in *New Frontiers in Dynamic Spectrum Access Networks, 2005. DySPAN 2005. 2005 First IEEE International Symposium on*, pp. 131–136, IEEE, 2005.
- [26] J. Unnikrishnan and V. V. Veeravalli, “Cooperative sensing for primary detection in cognitive radio,” *IEEE Journal of selected topics in signal processing*, vol. 2, no. 1, pp. 18–27, 2008.
- [27] Z. Quan, S. Cui, and A. H. Sayed, “An optimal strategy for cooperative spectrum sensing in cognitive radio networks,” in *Global Telecommunications Conference, 2007. GLOBECOM'07. IEEE*, pp. 2947–2951, IEEE, 2007.

- [28] Z. Quan, S. Cui, and A. H. Sayed, "Optimal linear cooperation for spectrum sensing in cognitive radio networks," *IEEE Journal of selected topics in signal processing*, vol. 2, no. 1, pp. 28–40, 2008.
- [29] E. C. Y. Peh, Y.-C. Liang, Y. L. Guan, and Y. Zeng, "Optimization of cooperative sensing in cognitive radio networks: a sensing-throughput tradeoff view," *Vehicular Technology, IEEE Transactions on*, vol. 58, no. 9, pp. 5294–5299, 2009.
- [30] W. Zhang, R. K. Mallik, and K. Letaief, "Optimization of cooperative spectrum sensing with energy detection in cognitive radio networks," *Wireless Communications, IEEE Transactions on*, vol. 8, no. 12, pp. 5761–5766, 2009.
- [31] F. Portelinha and P. Cardieri, "Collaborative spectrum sensing under spatially correlated shadowing fading," in *Simposio Brasileiro de Telecomunicacoes*, Wireless Technology Laboratory (WissTek), University of Campinas, 2009.
- [32] M. Renzo, L. Imbriglio, F. Graziosi, and F. Santucci, "Distributed data fusion over correlated log-normal sensing and reporting channels: Application to cognitive radio networks," *Wireless Communications, IEEE Transactions on*, vol. 8, no. 12, pp. 5813–5821, 2009.
- [33] A. Ghasemi and E. S. Sousa, "Asymptotic performance of collaborative spectrum sensing under correlated log-normal shadowing," *Communications Letters, IEEE*, vol. 11, no. 1, pp. 34–36, 2007.
- [34] C. Sun, W. Zhang, and K. Ben, "Cluster-based cooperative spectrum sensing in cognitive radio systems," in *Communications, 2007. ICC'07. IEEE International Conference on*, pp. 2511–2515, IEEE, 2007.
- [35] Y. Selén, H. Tullberg, and J. Kronander, "Sensor selection for cooperative spectrum sensing," in *New Frontiers in Dynamic Spectrum Access Networks, 2008. DySPAN 2008. 3rd IEEE Symposium on*, pp. 1–11, IEEE, 2008.

- [36] A. S. Cacciapuoti, I. F. Akyildiz, and L. Paura, “Correlation-aware user selection for cooperative spectrum sensing in cognitive radio ad hoc networks,” *Selected Areas in Communications, IEEE Journal on*, vol. 30, no. 2, pp. 297–306, 2012.
- [37] N. Reisi, V. Jamali, M. Ahmadian, and S. Salari, “Cooperative spectrum sensing over correlated log-normal channels in cognitive radio networks based on clustering,” in *Telecommunications (ConTEL), Proceedings of the 2011 11th International Conference on*, pp. 161–168, IEEE, 2011.
- [38] J. Wei and X. Zhang, “Energy-efficient distributed spectrum sensing for wireless cognitive radio networks,” in *INFOCOM IEEE Conference on Computer Communications Workshops, 2010*, pp. 1–6, IEEE, 2010.
- [39] W. Saad, Z. Han, M. Debbah, A. Hjørungnes, and T. Başar, “Coalitional games for distributed collaborative spectrum sensing in cognitive radio networks,” in *INFOCOM 2009, IEEE*, pp. 2114–2122, IEEE, 2009.
- [40] F. O. Karray and C. W. De Silva, *Soft computing and intelligent systems design: theory, tools, and applications*. Pearson Education, 2004.
- [41] A. Zilouchian and M. Jamshidi, *Intelligent control systems using soft computing methodologies*. CRC Press, Inc., 2000.
- [42] B. Chen, “Fuzzy logic membership function.” <http://www.bindichen.co.uk/post/AI/fuzzy-inference-membership-function.html>, 2013. Accessed: 2016-06-15.
- [43] E. H. Mamdani, “Application of fuzzy algorithms for control of simple dynamic plant,” in *Proceedings of the Institution of Electrical Engineers*, vol. 121, pp. 1585–1588, IET, 1974.
- [44] D. Kumar and P. Verma, “Comparative study of mamdani & takagi-sugeno models for spectrum access in cognitive radio networks,” in *International Conference on Computational Intelligence and Computing Research (IC-CIC)*, pp. 1–5, IEEE, 2015.

- [45] W. Na, H. Chaofang, and S. Wuxi, “A mamdani fuzzy modeling method via evolution-objective cluster analysis,” in *Control Conference (CCC), 2012 31st Chinese*, pp. 3470–3475, IEEE, 2012.
- [46] T. Takagi and M. Sugeno, “Fuzzy identification of systems and its applications to modeling and control,” *IEEE transactions on systems, man, and cybernetics*, no. 1, pp. 116–132, 1985.
- [47] T. J. Ross, *Fuzzy logic with engineering applications*. John Wiley & Sons, 2009.
- [48] H.-S. T. Le and H. D. Ly, “Opportunistic spectrum access using fuzzy logic for cognitive radio networks,” in *Communications and Electronics, 2008. ICCE 2008. Second International Conference on*, pp. 240–245, IEEE, 2008.
- [49] H. Zhang and X. Wang, “A fuzzy decision scheme for cooperative spectrum sensing in cognitive radio,” in *Vehicular Technology Conference (VTC Spring), 2011 IEEE 73rd*, pp. 1–4, IEEE, 2011.
- [50] W. Ejaz, N. ul Hasan, S. Aslam, and H. S. Kim, “Fuzzy logic based spectrum sensing for cognitive radio networks,” in *2011 Fifth International Conference on Next Generation Mobile Applications, Services and Technologies*, pp. 185–189, IEEE, 2011.
- [51] N. Baldo and M. Zorzi, “Cognitive network access using fuzzy decision making,” *IEEE Transactions on Wireless Communications*, vol. 8, no. 7, pp. 3523–3535, 2009.
- [52] X. Liu and N. S. Shankar, “Sensing-based opportunistic channel access,” *Mobile Networks and Applications*, vol. 11, no. 4, pp. 577–591, 2006.
- [53] D. Cabric, A. Tkachenko, and R. W. Brodersen, “Spectrum sensing measurements of pilot, energy, and collaborative detection,” in *Military Communications conference(MILCOM)*, pp. 1–7, IEEE, 2006.



- [54] M. Gudmundson, "Correlation model for shadow fading in mobile radio systems," *Electronics letters*, vol. 27, no. 23, pp. 2145–2146, 1991.
- [55] R. C. D. V. Bomfin and R. A. de Souza, "A new spatially correlated shadowed channel model with cognitive radio application," in *2015 IEEE 81st Vehicular Technology Conference (VTC Spring)*, pp. 1–5, IEEE, 2015.
- [56] Y. Jiao, P. Yin, and I. Joe, "Clustering scheme for cooperative spectrum sensing in cognitive radio networks," *IET Communications*, vol. 10, no. 13, pp. 1590–1595, 2016.
- [57] A. Goldsmith, *Wireless communications*. Cambridge university press, 2005.
- [58] J. Weitzen and T. J. Lowe, "Measurement of angular and distance correlation properties of log-normal shadowing at 1900 mhz and its application to design of pcs systems," *IEEE transactions on vehicular technology*, vol. 51, no. 2, pp. 265–273, 2002.
- [59] M. Motta, "A survey on data and decision fusion strategies on spectrum sensing in cognitive radio networks," *International Journal of Advanced Research in Computer and Communication Engineering*, vol. 3, no. 7, 2014.
- [60] E. Visotsky, S. Kuffner, and R. Peterson, "On collaborative detection of tv transmissions in support of dynamic spectrum sharing," in *New Frontiers in Dynamic Spectrum Access Networks, 2005. DySPAN 2005. 2005 First IEEE International Symposium on*, pp. 338–345, IEEE, 2005.
- [61] Z. Li, F. R. Yu, and M. Huang, "A cooperative spectrum sensing consensus scheme in cognitive radios," in *INFOCOM 2009, IEEE*, pp. 2546–2550, IEEE, 2009.
- [62] A. Ghasemi and E. S. Sousa, "Opportunistic spectrum access in fading channels through collaborative sensing.," *Journal of Communications*, vol. 2, no. 2, pp. 71–82, 2007.

# Appendix A

## Smart user selection based on fuzzy logic

```
%%Code written by Willy ATTIKEY  
%% Msc Student at Pan African University – Nairobi, Kenya  
%%Email: attiskey.willy@students.jkuat.ac.ke  
[System]  
Name= 'First-stage'  
Type= 'mamdani'  
Version=2.0  
NumInputs=2  
NumOutputs=1  
NumRules=9  
AndMethod= 'min'  
OrMethod= 'max'  
ImpMethod= 'min'  
AggMethod= 'max'  
DefuzzMethod= 'centroid'  
  
[Input1]  
Name= 'distance'  
Range=[0 150]  
NumMFs=3  
MF1= 'Close': 'trimf', [0 0 56.25]  
MF2= 'Average': 'trimf', [37.5 75 112.5]
```

```
MF3='Far': 'trimf',[94.5436507936508 150.793650793651
150.793650793651]
```

```
[Input2]
```

```
Name='decorrelation-distance'
```

```
Range=[30 100]
```

```
NumMFs=3
```

```
MF1='Low': 'trimf',[30 30 60]
```

```
MF2='Medium': 'trimf',[50 65 80]
```

```
MF3='Large': 'trimf',[70 100 100]
```

```
[Output1]
```

```
Name='correlation-coefficient'
```

```
Range=[0 1]
```

```
NumMFs=5
```

```
MF1='Very-Low': 'trimf',[0 0 0.2]
```

```
MF2='Low': 'trimf',[0.15 0.2753 0.4]
```

```
MF3='High': 'trimf',[0.6 0.7247 0.85]
```

```
MF4='Normal': 'trimf',[0.35 0.5 0.65]
```

```
MF5='Very-High': 'trimf',[0.8 1 1]
```

```
[Rules]
```

```
1 1, 2 (1) : 1
```

```
1 2, 3 (1) : 1
```

```
1 3, 5 (1) : 1
```

```
2 1, 1 (1) : 1
```

```
2 2, 2 (1) : 1
```

```
2 3, 4 (1) : 1
```

```
3 1, 1 (1) : 1
```

```
3 2, 1 (1) : 1
```

```
3 3, 4 (1) : 1
```

# Appendix B

## Fuzzy logic detection system

*%%Code written by Willy ATTIKEY*

*%% Msc Student at Pan African University – Nairobi, Kenya*

*%%Email: attiskey.willy@students.jkuat.ac.ke*

[ System ]

Name= 'second-stage '

Type= 'mamdani '

Version=2.0

NumInputs=2

NumOutputs=1

NumRules=25

AndMethod= 'min '

OrMethod= 'max '

ImpMethod= 'min '

AggMethod= 'max '

DefuzzMethod= 'centroid '

[ Input1 ]

Name= 'SNR '

Range=[-40 30]

NumMFs=5

MF1= 'Very-Weak ': 'gaussmf ', [5.733 -39.25]

MF2= 'weak ': 'gaussmf ', [4.247 -20]

MF3= 'zero ': 'gaussmf ', [5.478 -2.95]

MF4= 'strong ': 'gaussmf ', [4.247 15]

MF5='very-strong': 'gaussmf', [4.4 29.5]

[Input2]

Name='Correlation-Coefficient'

Range=[0 1]

NumMFs=5

MF1='low': 'gaussmf', [0.05298 0.2753]

MF2='Normal': 'gaussmf', [0.0637 0.5]

MF3='high': 'gaussmf', [0.05318 0.7247]

MF4='very-high': 'gaussmf', [0.076 1]

MF5='very-low': 'gaussmf', [0.07644 0.01]

[Output1]

Name='probability-of-detection'

Range=[0 1]

NumMFs=5

MF1='very-low': 'trimf', [-0.25 0 0.2]

MF2='low': 'trimf', [0.1 0.25 0.4]

MF3='medium': 'trimf', [0.3 0.5 0.7]

MF4='high': 'trimf', [0.6 0.75 0.9]

MF5='very-high': 'trimf', [0.8 1 1.25]

[Rules]

1 2, 1 (1) : 1

1 3, 1 (1) : 1

1 4, 1 (1) : 1

2 1, 1 (1) : 1

2 2, 1 (1) : 1

2 3, 1 (1) : 1

2 4, 1 (1) : 1

3 5, 3 (1) : 1

3 1, 2 (1) : 1  
3 2, 2 (1) : 1  
3 3, 1 (1) : 1  
3 4, 1 (1) : 1  
4 5, 5 (1) : 1  
4 1, 4 (1) : 1  
4 2, 2 (1) : 1  
5 5, 5 (1) : 1  
5 1, 5 (1) : 1  
5 2, 3 (1) : 1  
1 5, 1 (1) : 1  
1 1, 1 (1) : 1  
2 5, 1 (1) : 1  
4 3, 2 (1) : 1  
4 4, 1 (1) : 1  
5 3, 1 (1) : 1  
5 4, 1 (1) : 1

# Appendix C

## Probability of detection Based on Fuzzy logic

```
%%Code written by Willy ATTIKEY  
%% Msc Student at Pan African University – Nairobi, Kenya  
%%Email: attiskey.willy@students.jkuat.ac.ke
```

```
clc
```

```
close all
```

```
clear all
```

```
dcor_min = 30;  
dcor_max = 100;  
dist_min = 0;  
dist_max = 150;  
snr_min = -40; %dB  
snr_max = 30; %dB  
correlation_thresh = 2.7183(-1);  
less_correlated = [];  
index2 = 1;  
nb_links = 105; % for 25 nodes; ((n^2)-n)/2  
dcorr_distance1_hor(1:nb_links) = 30; %in meters  
dcorr_distance2_hor(1:nb_links) = 65;  
dcorr_distance3_hor(1:nb_links) = 100;  
dcorr_distance1 = (dcorr_distance1_hor)';
```

```

dcorr_distance2 = (dcorr_distance2_hor)';
dcorr_distance3 = (dcorr_distance3_hor)';

distance = (dist_max - dist_min).*rand(nb_links,1) + dist_min;

for index1 = 1:3 %compute the correlation coefficients for each
                    %link for different decorrelation distance
    for index2 = 1:nb_links
        fismat = readfis('shadow-fuzzy');
        if index1 == 1
            corr_coeff30_hor(index2) = evalfis([distance(index2)
            dcorr_distance1(index2)], fismat);
        elseif index1 == 2
            corr_coeff65_hor(index2) = evalfis([distance(index2)
            dcorr_distance2(index2)], fismat);
        else
            corr_coeff100_hor(index2) = evalfis([distance(index2)
            dcorr_distance3(index2)], fismat);
        end
    end
end

corr_coeff30 = (corr_coeff30_hor)';
corr_coeff65 = (corr_coeff65_hor)';
corr_coeff100 = (corr_coeff100_hor)';

%Sort the correlation coefficient values
%from smallest to largest
sort30 = sort(corr_coeff30);
sort65 = sort(corr_coeff65);
sort100 = sort(corr_coeff100);

```



```

par={'Distance' 'Decorrelation_Distance_for_30m'
'Correlation_Coefficient_for_30m' 'sorting_for_30m'
'Decorrelation_Distance_for_65m' 'Correlation_Coefficient_for_65_m'
'sorting_for_65m' 'Decorrelation_Distance_for_100m'
'Correlation_Coefficient_for_100m' 'sorting_for_100m';...
distance dcorr_distance1 corr_coeff30 sort30 dcorr_distance2
corr_coeff65 sort65 dcorr_distance3 corr_coeff100 sort100};
mypar=[distance dcorr_distance1 corr_coeff30 sort30 dcorr_distance2
corr_coeff65 sort65 dcorr_distance3 corr_coeff100 sort100];
save par
s1=xlswrite('C:\Users\MWA\Documents\MATLAB\myvalues.xls', par,
'willy', 'B1');
s2=xlswrite('C:\Users\MWA\Documents\MATLAB\myvalues.xls', mypar,
'willy', 'B3');

%second fuzzy system for smart prediction
sorted40_for30m = xlsread('myvalues.xls', 'willy', 'E3:E42');
sorted40_for65m = xlsread('myvalues.xls', 'willy', 'H3:H42');
sorted40_for100m = xlsread('myvalues.xls', 'willy', 'K3:K42');

snr_compar = (snr_max - snr_min).*rand(nb_links,1) + snr_min;
snr_compar_size = numel(snr_compar);
snr = snr_compar(randperm(snr_compar_size, 40));

for index3 = 1:3
    fismat_second = readfis('second-stage');
    for ii=1:40

        if index3 == 1
            probability30(ii) = evalfis([snr(ii)
sorted40_for30m(ii)], fismat_second);

```

```

        elseif index3 == 2
            probability65(ii) = evalfis([snr(ii)
            sorted40_for65m(ii)], fismat_second);
        else
            probability100(ii) = evalfis([snr(ii)
            sorted40_for100m(ii)], fismat_second);
        end
    end
end

%     snr(i)
%     sorted10(i)
%     probability

probability30_column = (probability30)';
probability65_column = (probability65)';
probability100_column = (probability100)';

%%Send the inputs values to the fuzzy system and store
%% it and the output in excel sheets%%
par2={'SNR' '40_Lowest_Correlation_coefficient_for_30m'
'Probability_for_30m' '40_Lowest_Correlation_coefficient_for_60m'
'Probability_for_60m' '40_Lowest_Correlation_coefficient_for_100m'
'Probability_for_100m';...
snr sorted40_for30m probability30_column sorted40_for65m
probability65_column sorted40_for100m probability100_column};
mypar2=[snr sorted40_for30m probability30_column sorted40_for65m
probability65_column sorted40_for100m probability100_column];
save par2
s3=xlswrite('C:\Users\MWA\Documents\MATLAB\myvalues.xls', par2,
'second_system', 'A1');

```

```

s4=xlswrite('C:\Users\MWA\Documents\MATLAB\myvalues.xls', mypar2,
'second_system', 'A3');

% % %%%%%%%%%% COMPARISON for 30m %%%%%%%%%%

corr_coeff_compar_30 = xlsread('myvalues.xls','willy','D3:D107');
fismat_compar = readfis('second-stage');

    for jj=1:105
        probability_compar(jj) = evalfis([snr_compar(jj)
        corr_coeff_compar_30(jj)], fismat_compar);
    end
probability_column_compar = (probability_compar)';

par3={'SNR' 'Correlation_coefficient' 'Probability_for_comparison';
snr_compar corr_coeff_compar_30 probability_column_compar};
mypar3=[snr_compar corr_coeff_compar_30 probability_column_compar];
save par3
s5=xlswrite('C:\Users\MWA\Documents\MATLAB\myvalues.xls', par3,
'comparison', 'A1');
s6=xlswrite('C:\Users\MWA\Documents\MATLAB\myvalues.xls', mypar3,
'comparison', 'A3');

```

# Appendix D

## Algorithm of multi-hop architecture

*%%Code written by Willy ATTIKEY*

*%% Msc Student at Pan African University – Nairobi, Kenya*

*%%Email: attikey.willy@students.jkuat.ac.ke*

**clc**

**close all**

**clear all**

node = 3;

cluster = 6;

snr = xlsread('myvalues.xls', 'second\_system', 'A2:A41');

colorVec = **hsv**(4);

prob\_30 = xlsread('myvalues.xls', 'second\_system', 'C2:C41');

prob\_65 = xlsread('myvalues.xls', 'second\_system', 'E2:E41');

prob\_100 = xlsread('myvalues.xls', 'second\_system', 'G2:G41');

*%%For comparison%%*

snr\_compar\_30 = xlsread('myvalues.xls', 'Sheet2', 'A1:A33');

prob\_compar\_30 = xlsread('myvalues.xls', 'Sheet2', 'C1:C33');

xx = numel(prob\_compar\_30);

Qd\_compar\_30 = 1-(1-prob\_compar\_30).^3;

**figure**(3);

**plot**(snr\_compar\_30, Qd\_compar\_30, '-.g\*')

```

hold on;
% title('Probability of detection for different decorrelation
%distance')
xlabel('SNR') % x-axis label
ylabel('Probability_of_Detection') % y-axis label
%legend('D = 30m', 'D = 65m', 'D = 100m', 'Location', 'southeast')
hold off;
%%End comparison%%

```

```

%% For 30m decorrelation distance %%

```

```

Qd_30_3 = 1-(1-prob_30).^3;
Qd_65_3 = 1-(1-prob_65).^3;
Qd_100_3 = 1-(1-prob_100).^3;

```

```

figure(1);

```

```

plot(snr, Qd_30_3, '-.g*')
hold on;
plot(snr, Qd_65_3, '--ro')
plot(snr, Qd_100_3, ':bs')
xlabel('SNR') % x-axis label
ylabel('Probability_of_Detection') % y-axis label
legend('D=30m', 'D=65m', 'D=100m', 'Location', 'southeast')
hold off;

```

```

Qd_total_30_3 = 0.5*(1-(1-2*Qd_30_3).^cluster);
Qd_total_65_3 = 0.5*(1-(1-2*Qd_65_3).^cluster);
Qd_total_100_3 = 0.5*(1-(1-2*Qd_100_3).^cluster);

```

```

figure(2);

```

```

% Plotting Qd and Qf total
plot(snr,Qd_total_30_3,'-g*')
hold on;
plot(snr,Qd_total_65_3,'--ro')
plot(snr,Qd_total_100_3,':bs')

% title('Multi-hop Probability of detection for
different decorrelation distance')
xlabel('SNR') % x-axis label
ylabel('Probability of Detection') % y-axis label
legend('D=30m','D=65m','D=100m','Location','southeast')
hold off;

```

# Fuzzy Logic Based Smart User Selection for Spectrum Sensing under Spatially Correlated Shadowing

Attikey M. Willy<sup>1,\*</sup>, Dr Peter Kihato<sup>2</sup> and Prof. Vitalice Oduol<sup>3</sup>

<sup>1</sup> Master Student (Electrical Engineering Department, Pan African University - Institute for Basic Sciences, Technology and Innovation, PAUISTI, JKUAT - JUJA Campus P.O. Box 62,000 - 00200 NAIROBI, KENYA).

<sup>2</sup> Senior Lecturer (Jomo Kenyatta University of Agriculture and Technology, JKUAT - JUJA Campus P.O. Box 62,000 - 00200 NAIROBI, KENYA).

<sup>3</sup> Senior Lecturer (University of Nairobi - Nairobi Campus P.O.Box 30197, GPO, NAIROBI, KENYA).

\*Corresponding Author - E-mail: Email: mensahwilly@gmail.com / attikey.willy@students.jkuat.ac.ke.

---

**Abstract** Cognitive Radio has been invented to provide wireless communications with efficient radio spectrum utilization. Cooperative spectrum sensing, was introduced to alleviate the hidden terminal problem resulting from spectrum sensing. However, cooperation gain is affected among others by correlated shadowing in the sensing and the reporting channels respectively. In this paper, we propose a two-stage fuzzy logic based local spectrum sensing scheme. In the first stage, less correlated users are selected from a set of randomly spread nodes. In the second stage, the output from stage 1 is combined to generated signal-to-noise-ratio values to provide an enhancement in detection of primary user. The simulation shows that our scheme can achieve high accurate spectrum sensing which in effect gives a higher probability of detection than the distance-based user selection approach.

**Keywords** Cognitive radio, Cooperative spectrum sensing, Fuzzy logic, Spatially correlated shadowing.

## 1. Introduction

Spectrum sensing is a key feature in cognitive radio networks (CRN). These networks, have arisen to cope with spectrum wastage which is a serious challenge in wireless communication due to the finite availability of bandwidth. According to the Federal Communications Commission (FCC), regarding time or location, spectrum band utilization ranges from 15% to 85% [1]. In CRN, secondary users (SUs) access opportunistically the licensed band of frequency after sensing the absence of primary users (PU) and should vacate it when their presence is sensed without causing harmful interference. Practically, in real environments, spectrum sensing might experience different issues like multipath fading and shadowing which will yield to a degradation of the overall performance of the system [2]. This is where cooperative spectrum sensing (CSS) came up as a breakthrough to solve the aforementioned challenges.

CSS uses spatial diversity to make SU to cooperate by gathering their local sensing outcomes and thereby

achieves more accurate detection and increases the sensing performance [3]. Many researchers have studied widely cooperative sensing [4] [5] and have showed that CSS is a threefold process: Local Sensing, Reporting and Data Fusion. During local sensing, each SU senses the environment and makes its own decision (presence or absence of PU) which is sent to the fusion centre (FC) in the course of the reporting period. Finally, during the data fusion, the FC gathers all the decisions received and make a final one which is forwarded to all the SUs.

Cooperative gain, known as the improvement obtained from CSS, can be degraded when observations of SUs are made under spatially correlated shadow fading [6]. The latter happens when nodes located close to each other are blocked by the same obstacle which can result in misdetection of the PU and therefore, severely degrade the performance of the system. Gudmundson [7] developed a distance dependent correlation model which has been adopted in several literatures. In [8], Ghasemi and Sousa were able to show the degrading effect of the correlated

shadowing on the detection performance in a collaborative scheme. By using two SUs located at various distances, the probabilities of detection and false alarm were compared and each of the probabilities got worse as well as the SUs were located too close. Correlated shadowing reduces cooperative gain and hence it is better for a few independent SUs to collaborate than several correlated nodes [4]. In [9], a correlation aware algorithm is developed whereby the least correlated users are selected to cooperate.

We propose in this paper, a smart user selection method to combat correlated shadowing based on Fuzzy logic in order to improve the efficiency of the detection system. Many papers have extensively studied the adoption of fuzzy logic in cognitive radio networks [10] [11] [12]. By using Fuzzy Logic, we bring intelligence based on expert knowledge and the system is twofold. Firstly, the smart user selection is based on a decreasing correlation function developed by Gudmundson. The proposed correlation model is given by:

$$e^{-\frac{d_{ip}}{D}} \quad (1.1)$$

where  $d_{ip}$  represents distance between any two users and  $D$  is called the decorrelation distance and depends on the environment. The decorrelation distance can be explained as the minimum separation distance from which any two CR users do not undergo shadowing correlation. The higher  $D$  is, the more any given two CR users tend to suffer spatially correlated shadowing. Secondly, the output of the previous system is combined with other parameters through another fuzzy logic based system to decide efficiently on the presence or the absence of a PU. The rest of this paper is organized as follows. In Section II, the system model is presented and analyzed. The proposed fuzzy logic based systems are thoroughly detailed in Section III. In section IV, simulations and results are discussed. Finally, conclusions are made in Section V.

## 2. System model

We consider a cognitive radio network made of  $N$  nodes, randomly spread on a 150m x 150m field, which sense the primary frequency to detect the presence or absence of any licensed user as described in the Figure 1: Network model.

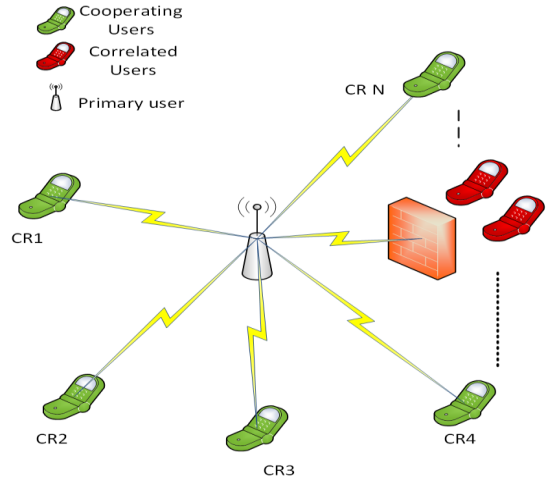

Fig. 1. Network model

Among the set of  $N$  nodes, we will select the 20 less correlated to cooperate. To do so, SUs and a PU are located in a close area. Spectrum sensing is done in a centralized fashion by the SUs. We assume cognitive users are aware of the relative distance between each other and the PU by using Global Positioning System(GPS) technology. We adopt two fuzzy logic systems, one to model the spatial correlation and the second to implement the spectrum sensing. The proposed method can be described in the following steps:

Firstly, SUs who will cooperate are selected based on the correlation coefficient stated in Equation (1.1) which represents the output of the first fuzzy system. There are two inputs which are respectively the distance separating the nodes and the decorrelation distance  $D$  which varies from 30 to 100 meters for outdoor systems [13] [14]. The distance is the separation between any two CR users and is given, for  $i^{th}$  and  $p^{th}$  CR users, by

$$d_{ip} = \sqrt{(x_i - x_p)^2 + (y_i - y_p)^2} \quad (1.2)$$

The paper studies the cases where  $D$  takes respectively three different values: 30, 60 and 100 meters. The crisp values of the correlation coefficient obtained for each input are compared to a threshold  $\epsilon_d = e^{-(D/D)} = e^{-1}$  which represents the maximum correlation coefficient, based on Gudmundson's model [7], that should not be exceeded. The SUs whose correlation coefficient is above the threshold, are considered correlated and will not participate in the CSS. Assuming  $M$  SUs are remaining, the 20 less correlated users are selected and their



correlation coefficient will be used as input for the second stage. The inputs are generated randomly in the simulation tool. Below is the fuzzy system on Figure 2 which is used to select less correlated users. Figures 3 and 4 depict the diagrammatic representation of the inputs and outputs membership functions of the two fuzzy systems.

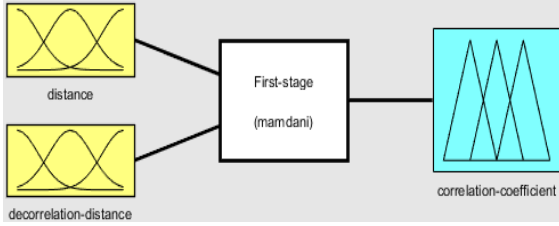

Fig. 2. Smart User selection based on Fuzzy logic

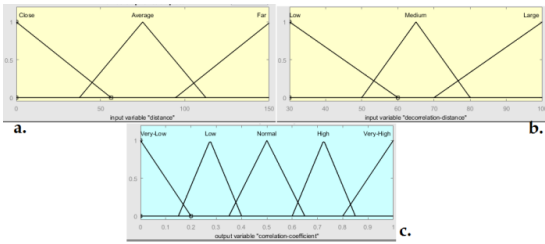

Fig. 3. Membership function plots a) distance, b)decorrelation distance, c)Correlation coefficient of first fuzzy system

At the second stage, the correlation coefficients of the twenty less correlated users for the three different decorrelation distances, are collected and combined to generated signal to noise ratio (SNR) variables as inputs for a spectrum sensing system based on fuzzy logic. Considering a SU  $i^{th}$ , the SNR formula is given by

$$SNR_{pi} = |h_{pi}|^2 E_p N_o \quad (1.3)$$

where  $h_{pi}$  is the channel gain between the PU and  $i^{th}$  SU,  $E_p$  is the energy of primary signal and  $N_o$  is the variance of Additive White Gaussian Noise (AWGN). Spectrum sensing at each CR user can be represented as a binary hypothesis test given in

$$r(t) = \begin{cases} n(t) & H_0 (Pu \text{ is absent}) \\ hs(t) + n(t) & H_1 (Pu \text{ is present}) \end{cases} \quad (1.4)$$

where  $r(t)$  is the received signal,  $s(t)$  is the primary transmitted signal,  $n(t)$  is AWGN and  $h$  is the channel gain.  $H_0$  indicates the absence of primary user (spectrum

hole available) and  $H_1$  the presence of primary user (spectrum hole not available). As shown on Figure 4 the output here is the probability of detection for different values of decorrelation distances.

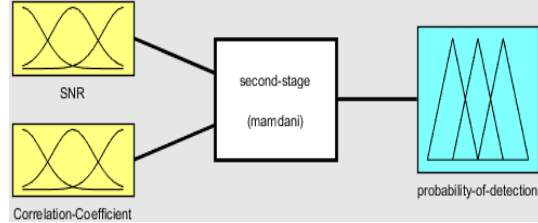

Fig. 4. Probability of detection based on Fuzzy logic

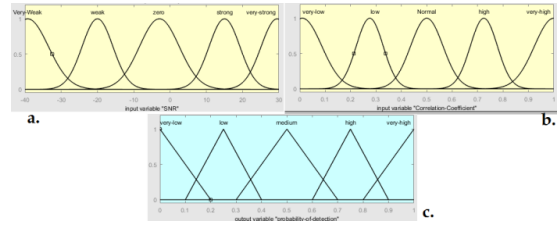

Fig. 5. Membership function plots a)SNR, b)correlation-coefficient, c)probability of detection of second fuzzy system

### 3. Framework

#### 3.1. Smart User Selection

To apply fuzzy logic to correlated shadowing, we come up with a simple fuzzy algorithm which takes as inputs two parameters and gives one parameter as output.

The proposed fuzzy system has two inputs with three membership functions each and one output with five membership functions. The *distance* membership functions are labeled as *close*, *average* and *far* which show how close or far two specific SUs are. Regarding the *decorrelation distance*, the membership functions are called as *low*, *medium* and *large*. The names of the membership functions of the *correlation coefficient*, which is the output, are *very low*, *low*, *normal*, *high* and *very high* which indicates how correlated two SUs are. Min-Max is used as the implication and aggregation methods and centroid as defuzzification method [15]. We use triangular membership functions of same shape for both inputs and output. The latter is normalized on a scale of 0 to 1 and compared to a threshold of  $\epsilon_d = e^{-(D/D)} = e^{-1}$ . SUs with a correlation coefficient less than the threshold are said not correlated and correlated otherwise. The knowledge base of the fuzzy system is presented in Table 1. There is a total of 9 rules. For example, if the distance input is *average* and the decorrelation distance input is

low then the combined fuzzy decision is *very low* and that means the nodes on that link are not correlated.

**Table 1:** Rules base for fuzzy based user selection

Distance	Decorrelation distance	Correlation coefficient
close	low	normal
close	medium	high
close	large	very high
average	low	very low
average	medium	low
average	large	normal
far	low	very low
far	medium	low
far	large	normal

### 3.2. Designing the Fuzzy Logic System for Spectrum Sensing Problem

To design the fuzzy logic based spectrum sensing system, the twenty lowest correlation coefficients of the first fuzzy system are taken as one of the inputs. The second input is generated SNR which varies from - 40 to 30 dB. The output, the probability of detection varies between 0 to 1.

For the sake of simplicity, both inputs have five membership functions named as very weak, weak, zero, high and very high for the SNR and the correlation coefficient input named as in the previous system. The output has also five membership functions labelled very low, low, medium, high and very high. For the inputs, Gaussian membership functions are used while triangular ones for the output. We use Gaussian membership functions here, because of the smoothness of their slope which supports more the characteristic of fuzzy logic between two successive ranges. We study with this system the probability of detection with correlation coefficients obtained for 3 different values of decorrelation distance. This will show the impact of correlation between close users on the detection system. Also, here Min-Max is used as the implication and aggregation methods and centroid as defuzzification method. Since this paper is dealing with a specific type of fading which is the correlated shadowing, it does not consider any other condition which can degrade the SNR values. It is assumed therefore, that in condition of low correlation coefficient, the SNR is relatively good. Starting from the same assumption, we just consider 18 rules out of 25 for the knowledge base displayed in Table 2. For example, the rule if correlation coefficient is high and SNR is strong, probability is medium is left aside because when two SUs are correlated, which means there are relatively too closed and are blocked by the same obstacle, their SNR is degraded

because of the fading effect and therefore we assume that the correlation coefficient could not be high while the SNR is strong.

**Table 2:** Rules base for fuzzy based spectrum sensing

SNR	Correlation coefficient	Probability of Detection
very weak	normal	low
very weak	high	very low
very weak	very high	very low
weak	low	very low
weak	normal	very low
weak	high	very low
weak	very high	very low
zero	very low	medium
zero	low	low
zero	normal	low
zero	high	very low
zero	very high	very low
strong	very low	very high
strong	low	high
strong	normal	medium
very strong	very low	very high
very strong	low	very high
very strong	normal	low

## 4. Simulation

As shown on Figure 6, the lowest correlation coefficients are obtained when distance separating two nodes is 55 meters and above for a decorrelation distance less than 60 meters. This portion of the surface represents actually the uncorrelated users since the correlation coefficient in that region is less than the threshold of  $e^{-1} \approx 0.3679$ . For the distance range mentioned previously, the correlation coefficient increases by 25% twice. It increases the first time when the decorrelation distance varies from 60 meters to 80 meters and the second time when the decorrelation distance exceeds 80 meters. The region of distance less than 50 meters records the highest correlation coefficients which results in highly correlated users. This high correlation between the CR users can be explained by the short distance between them making them to be prone to correlated shadowing. This relation between the distance and the correlation coefficient follows the same growth scheme of 25 % as the decorrelation distance increases and reaches the peak values for decorrelation distance above 80 meters.

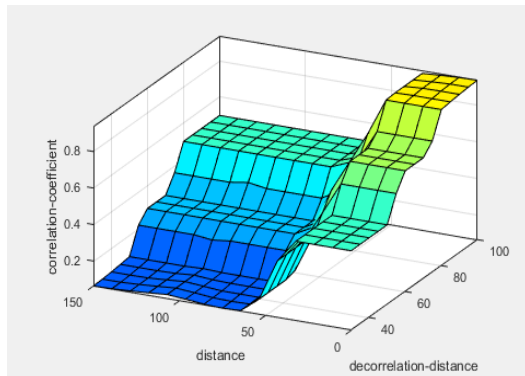

**Fig. 6.** Surface plot of the fuzzy based smart user selection

Figure 7 depicts the fuzzy based probability of detection in three different cases of the decorrelation distance: 30, 60 and 100 meters. Actually, the lowest correlation coefficients are obtained with the 30m decorrelation distance. This is more clarified by the fact that the considered network is of 150m x 150m size. Therefore, the chances for any two CR users to be separated by a distance of less than 30m is reduced leading also to less users affected by spatially correlated shadowing. Contrarily, a decorrelation distance of 100m yields to a high correlation coefficient which in turn degrades the probability of detection. This is explained by the fact that when the decorrelation distance is high enough(100m) in a case where distance separating SUs is not quite higher, the latter tend to experience correlated shadowing.

By comparing our results to the distance-based algorithm, we can see that our fuzzy based system performs better. Furthermore, we can notice that in very low SNR conditions and for the lowest value of decorrelation distance, our system outperforms the distance-based one. Furthermore, our system is able to achieve high detection performance when the decorrelation distance is very low which shows how correlated users can degrade the overall system.

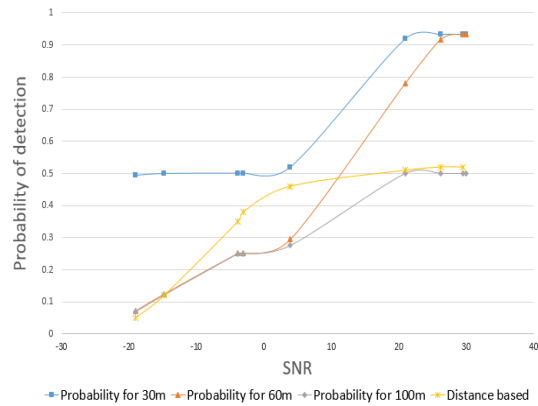

**Fig. 7.** Fuzzy based Probability of Detection for different decorrelation distance values

## 5. Conclusions

The contribution of this paper is in two-fold. Firstly, we presented a smart user selection scheme whereby only uncorrelated users are selected to cooperate. This approach has demonstrated to be accurate enough by selecting the less correlated users. Secondly, we developed a spectrum sensing technique which shows its performance by exhibiting good probability of detection. We analysed it in different cases of decorrelation distance to show the impact of correlated users on the detection of primary user where the probability of detection is higher when the decorrelation distance is low. In addition, the system performs better than the distance-based user selection.

The future work will be to take into consideration different fading conditions to simulate a more practical environment.

## References

- [1] Federal Communications Commission Spectrum Policy Task Force, "Spectrum policy task force report," Federal Communications Commission ET Docket, 2002.
- [2] R. Umar and A. U. H. Sheikh, "A comparative study of spectrum awareness techniques for cognitive radio oriented wireless networks," *Elsevier B.V.*, vol. 9, pp. 148--170, 2013.
- [3] I. Akyildiz, B. Lo and R. Balakrishnan, "Cooperative spectrum sensing in cognitive radio networks: A survey," *Elsevier B.V.*, vol. 4, pp. 40--62, 2011.
- [4] B. Khaled, B. Letaief and W. Zhang, "Cooperative Communications for Cognitive Radio Networks," *Proceedings of the IEEE*, vol. 97, no. 5, 2009.
- [5] S. M. Mishra, A. Sahai and R. Brodersen, "Cooperative sensing among cognitive radios," *Icc'06. IEEE*, vol. 4, pp. 1658--1663, 2006.

- [6] F. Portelinha and P. Cardieri, "Collaborative Spectrum Sensing under Spatially Correlated Shadowing Fading," 2012.
- [7] M. Gudmundson, "Correlation Model for Shadow Fading in Mobile Radio Systems," *Electronics Letters*, vol. 27, no. 23, pp. 45--46, 1991.
- [8] A. Ghasemi and E. S. Sousa, "Collaborative spectrum sensing for opportunistic access in fading environments," *2005 1st IEEE International Symposium on New Frontiers in Dynamic Spectrum Access Networks, DySPAN 2005*, pp. 131--136, 2005.
- [9] A. S. Cacciapuoti, I. F. Akyildiz and L. Paura, "Correlation-aware user selection for cooperative spectrum sensing in cognitive radio ad hoc networks," *IEEE Journal on Selected Areas in Communications*, vol. 30, no. 2, pp. 297--306, 2012.
- [10] P. Maheshwari and A. K. Singh, "A fuzzy logic based approach to spectrum assignment in cognitive radio networks," in *Advance Computing Conference (IACC), 2015 IEEE International*, 2015.
- [11] W. Ejaz, N. Ul Hasan, S. Aslam and H. S. Kim, "Fuzzy logic based spectrum sensing for cognitive radio networks," in *Fifth International Conference on Next Generation Mobile Applications, Services and Technologies*, 2011.
- [12] H.-S. Le and H. Ly, "Opportunistic spectrum access using fuzzy logic for cognitive radio networks," in *Communications and Electronics, 2008. ICCE 2008. Second International Conference on*, 2008.
- [13] A. Goldsmith, *Wireless communications*, Cambridge university press, 2005.
- [14] J. Weitzen and T. Lowe, "Measurement of angular and distance correlation properties of log-normal shadowing at 1900 MHz and its application to design of PCS systems," *IEEE transactions on vehicular technology*, vol. 51, no. 2, pp. 265--273, 2002.
- [15] F. O. Karray and C. W. De Silva, *Soft computing and intelligent systems design: theory, tools, and applications*, 2004.