

**SUITABILITY OF CRUSHED CERAMIC AND PORCELAIN  
CLAY TILES AS PARTIAL REPLACEMENT OF CEMENT IN  
CONCRETE**

**OLENG MORRIS**

**MASTER OF SCIENCE IN CIVIL ENGINEERING  
(STRUCTURAL OPTION)**

**PAN AFRICAN UNIVERSITY INSTITUTE FOR BASIC  
SCIENCES, TECHNOLOGY AND INNOVATION**

**2018**

**Suitability of Crushed Ceramic and Porcelain Clay Tiles as Partial  
Replacement of Cement in Concrete**

**Oleng Morris**

**CE 300 – 0005/17**

**A Thesis Submitted to the Department of Civil Engineering in the  
Institute of Basic Science Technology and Innovation in Partial  
Fulfilment for the Award of the Degree of Master of Science in Civil  
Engineering (Structural Option) of the Pan African University**

**2018**

**DECLARATION AND RECOMMENDATION**

**DECLARATION**

This thesis is my original work and has not been presented for a degree in any other University.

Signature: ..... Date: .....

Oleg Morris

CE300 – 0005/17

**RECOMMENDATION**

This thesis has been submitted with our approval as the University Supervisors.

Signature: ..... Date: .....

Prof. Dr. - Ing. Zachary C. Abiero - Gariy (PhD)

Department of Civil Engineering, (JKUAT) Nairobi, Kenya.

Signature: ..... Date: .....

Prof. Christopher Kanali

Agricultural and Biosystems Engineering Department, (JKUAT) Nairobi, Kenya.

Signature: ..... Date: .....

Dr. Erick Ronoh

Agricultural and Biosystems Engineering Department, (JKUAT) Nairobi, Kenya.

## **DEDICATION**

I dedicate this study to my parents Silvesto Amuko Oleng and Florence Amuko Oleng for their relentless support towards my academic pursuits. I also dedicate it to my late auntie Olga Icaika Oleng for her encouragement and advice.

## **ACKNOWLEDGEMENT**

First and foremost, every success gained is attributed to the grace of the Almighty God for good health and energy to work consistently on this research thesis. Secondly, special thanks goes to the management of the Pan African University as well as that of Jomo Kenyatta University of Agriculture and Technology for the awesome support offered during this study. I sincerely appreciate the university administration for their dedicated service throughout the entire period. I would also like to acknowledge my supervisors, Prof. Zachary Gariy, Prof. Christopher Kanali and Dr. Erick Ronoh for their relentless and highly dedicated technical support, daily supervision, guidance and consultation during the entire exercise. Finally, I acknowledge any other person who has had a positive addition to this thesis. These include my classmates among others.

## TABLE OF CONTENTS

DECLARATION AND RECOMMENDATION .....	i
DEDICATION .....	ii
ACKNOWLEDGEMENT .....	iii
TABLE OF CONTENTS .....	iv
LIST OF TABLES .....	viii
LIST OF FIGURES .....	ix
LIST OF APPENDICES .....	xi
LIST OF ABBREVIATIONS AND ACRONYMS.....	xii
LIST OF SYMBOLS .....	xiii
DEFINITIONS .....	xvi
ABSTRACT.....	xxi
CHAPTER ONE .....	1
1 INTRODUCTION .....	1
1.1 Background to the Study.....	1
1.2 Statement of the Problem.....	3
1.3 Objectives .....	7
1.3.1 General Objective .....	7
1.3.2 Specific Objectives .....	7
1.4 Research Questions .....	7
1.5 Justification .....	7
1.6 Scope and Limitations.....	9
1.6.1 Scope of the Study .....	9
1.6.2 Limitations .....	10

CHAPTER TWO .....	11
2 LITERATURE REVIEW .....	11
2.1 Introduction.....	11
2.2 Theoretical Review .....	11
2.2.1 Concrete .....	11
2.2.2 Classification of Concrete.....	13
2.2.3 Constituent Materials for Making Concrete.....	16
2.2.4 Desirable Properties of Concrete .....	22
2.2.5 Waste Ceramic and Porcelain Clay Tile Powder .....	32
2.2.6 Environmental Impact Assessment.....	34
2.3 Empirical Review.....	36
2.3.1 Engineering Properties of Waste Material Used as Partial Replacement of Cement in Concrete .....	36
2.3.2 Performance of Structural Concrete Mix with Waste Material used as Partial Replacement.....	38
2.3.3 Cost-Benefit of using Waste Material as Partial Replacement of Cement .....	45
2.4 Literature Review Summary and Research Gaps .....	48
2.5 Conceptual Framework.....	50
CHAPTER THREE.....	51
3 MATERIALS AND METHODS.....	51
3.1 Introduction.....	51
3.2 Determining Engineering Properties of Ceramic and Porcelain Clay Tile Powders.....	51

3.2.1	Material Acquisition and Preparation .....	51
3.2.2	Data Collection Procedure .....	54
3.2.3	Data Analysis .....	58
3.3	Evaluating the Performance of Concrete with Ceramic and Porcelain Clay Tile Powders as Partial Cement Substitutes.....	59
3.3.1	Material Acquisition and Preparation .....	59
3.3.2	Experimental Setup .....	61
3.3.3	Data Collection Procedure .....	62
3.3.4	Data Processing and Analysis .....	66
3.4	Analysing the Cost-Benefit of Using Ceramic and Porcelain Powders in Concrete .....	68
3.4.1	Data Collection Procedure .....	68
3.4.2	Data Analysis .....	69
CHAPTER FOUR.....		71
4	RESULTS AND DISCUSSION .....	71
4.1	Engineering Properties of Crushed Ceramic and Porcelain Clay Tile Powders .....	71
4.2	Performance of Concrete Mix obtained from Crushed Ceramic and Porcelain Clay Tile Powders as Partial Cement Substitutes .....	74
4.2.1	Material Characterization and Concrete Mix Design .....	74
4.2.2	Workability of Fresh Concrete.....	77
4.2.3	Compressive Strength of Hardened Concrete.....	78
4.2.4	Splitting Tensile Strength of Hardened Concrete .....	82



4.3	Cost benefit of using Crushed Ceramic and Porcelain Clay Tiles as Partial Replacement of Cement in concrete .....	86
4.3.1	Cost Assessment .....	86
4.3.2	Environmental Impact Assessment.....	89
CHAPTER FIVE.....		92
5	CONCLUSIONS AND RECOMMENDATIONS .....	92
5.1	Conclusions.....	92
5.2	Recommendations.....	93
5.2.1	For Possible Application.....	93
5.2.2	For Further Study .....	93
5.3	Achievements.....	94
REFERENCES.....		96

## LIST OF TABLES

Table 2.1: Classification of concrete in accordance with unit weight .....	14
Table 2.2: Classification of concrete in accordance with compressive strength.....	14
Table 2.3: Concrete classifications in accordance with additives.....	15
Table 2.4: Compounds in Portland cement .....	17
Table 2.5: Functions of compounds in cement .....	18
Table 2.6: Actual strength classes commonly used in reinforced concrete design ....	28
Table 2.7: Values of the secant modulus of elasticity $E_{cm}$ (in $\text{kN/mm}^2$ ).....	31
Table 3.1: Geographical coordinates of study sites .....	52
Table 3.2: Test methods for properties of ceramic and porcelain clay tile powders .	54
Table 3.3: Physical properties of ordinary Portland cement .....	59
Table 3.4: Chemical composition of ordinary Portland cement (OPC).....	60
Table 3.5: Physical properties of aggregates.....	63
Table 4.1: Physical properties of ceramic and porcelain clay tile powders. ....	71
Table 4.2: Concrete trial mix proportions for test specimen.....	76
Table 4.3: Material cost for conventional concrete.....	87
Table 4.4: Material cost for concrete with 20% cement replacement.....	87

## LIST OF FIGURES

Figure 2.1: Normal frequency distribution of strengths.....	23
Figure 2.2: Failure patterns of cubes.....	24
Figure 2.3: Splitting tensile strength specimen.....	26
Figure 2.4: Failure patterns of cylinders.....	27
Figure 2.5: Flexural strength beam setup.....	29
Figure 2.6: Typical stress-strain relationship for concrete.....	30
Figure 2.7: Ceramic tile waste at demolition site.....	33
Figure 2.8: Conceptual framework.....	50
Figure 3.1: Location of study area.....	53
Figure 3.2: Schematic diagram for determining engineering properties of ceramic and porcelain clay tile powders.....	55
Figure 3.3: Le-Chatelier flask for determining specific gravity.....	56
Figure 3.4: Vicat apparatus for determining consistency and setting time.....	57
Figure 3.5: X-Ray fluorescence spectrometer.....	58
Figure 3.6: Flow chart for evaluating the performance of concrete mix obtained from ceramic and porcelain clay tile powders as partial cement substitutes.....	62
Figure 3.7: Slump measurement and its forms.....	64
Figure 3.8: Slump cone apparatus.....	65
Figure 3.9: Universal testing machine for determining strength of concrete.....	66
Figure 4.1: Chemical composition of cement, and ceramic and porcelain powders.....	72
Figure 4.2: Particle size distribution of fine aggregates.....	74
Figure 4.3: Particle size distribution of coarse aggregates.....	75
Figure 4.4: Variation of slump with percentage cement replacement.....	77

Figure 4.5: Compressive strengths for various cement replacement levels at different ages.....	79
Figure 4.6: Prediction of compressive strengths for various cement replacement levels at different ages of curing. ....	81
Figure 4.7: Tensile strengths for various cement replacement levels at different ages.....	83
Figure 4.8: Prediction of splitting tensile strengths for various cement replacement levels at different ages of curing. ....	84
Figure 4.9: Relationship between compressive and splitting tensile strengths.....	86
Figure 4.10: Unit cost of materials per cubic metre for various cement replacement levels. ....	88
Figure 4.11: Abiotic depletion .....	89
Figure 4.12: Global warming .....	90

## LIST OF APPENDICES

Appendix A: Concrete Mix Design Tables .....	107
Appendix B: Laboratory Test Certificates .....	111
Appendix B1: Chemical composition of ceramic powder .....	111
Appendix B2: Chemical composition of porcelain powder .....	112
Appendix B3: Characterisation of coarse aggregates.....	113
Appendix B4: Characterisation of fine aggregates (sand).....	114
Appendix B5: Compressive strength of concrete for various cement replacement levels at different ages .....	115
Appendix C: Material Cost of Production of 1 m <sup>3</sup> of Concrete.....	137
Appendix C1: Material Breakdown for C25 cement concrete (1:2:3).....	137
Appendix C2: Calculation of Unit Price of Concrete Production .....	138
Appendix D: Environmental Impact Considerations .....	141
Appendix D1: Abiotic depletion .....	141
Appendix D2: Global warming .....	142
Appendix E: Publications.....	143

## **LIST OF ABBREVIATIONS AND ACRONYMS**

ASTM	:	American Standard of Testing Materials
BS	:	British Standards
CKD	:	Cement Kiln Dust
DSP	:	Densified with Small Particles
EC	:	Euro Code
EMP	:	Environment Management Plan
FRC	:	Fibre Reinforced Concrete
GDP	:	Gross Domestic Product
IS	:	Indian Standards
KES	:	Kenyan Shillings
MDF	:	Macro Defect Free
MPa	:	Mega Pascal
NEMA	:	National Environment Management Authority
NW&SC	:	National Water and Sewerage Corporation
OPC	:	Ordinary Portland cement
R.C	:	Reinforced Concrete
U.K	:	United Kingdom
UShs	:	Ugandan Shillings
UTM	:	Universal Testing Machine

## LIST OF SYMBOLS

$f_{ck}$	Characteristic compressive cylinder strength of concrete
$\sigma$	Standard deviation
$(CO_2)_r$	Percentage carbon dioxide reduction
$(K, Na)_2O \cdot Al_2O_3 \cdot 6H_2O$	Feldspar
$A_c$	Cross-sectional area of the specimen
$AD_r$	Percentage abiotic depletion reduction
$Al_2O_3$	Aluminium Oxide
$Al_2Si_2O_5(OH)_4$	Kaolin
$C$	Cement content in kg
$C_0$	Material cost of conventional concrete mix
$C_{20}$	Material cost of optimal concrete mix
$C_2S$	Belite
$C_3A$	Celite
$C_3S$	Alite
$C_4AF$	Felite
$CaO$	Calcium Oxide
$CE_c$	CO <sub>2</sub> emission in production of one ton of cement
$CE_w$	CO <sub>2</sub> emission in production of one ton of waste powders
$C_r$	Percentage cost reduction
$D$	Density of the material
$D$	Density of the material.
$d$	Designated cross-sectional dimension
$E_c$	Energy required for production of 1 kg of cement

$E_{cm}$	Secant modulus
$E_w$	Energy required for production of 1 kg of waste powders
$f$	Cube strength
$F$	Maximum load at failure
$f_{ck, cube}$	Equivalent characteristic cube strength at 28 days.
$f_{cs}$	Compressive strength
$f_{ctk}$	Characteristic tensile strength
$f_{ctk0.05}$	Lower characteristic compressive strength at 5% fractile
$f_{ctk0.95}$	Upper characteristic compressive strength at 95% fractile
$f_{ctm}$	Mean tensile strength
$Fe_2O_3$	Iron Oxide
$f_k$	Characteristic cylinder strength at 28 days
$f_m$	Mean strength
$f_{ts}$	Tensile splitting strength
$K_2O$	Potassium Oxide
$L$	Length of the line of contact of the specimen
$M$	Mass of the material
$M$	Mass of material
$MgO$	Magnesium Oxide
$n$	Number of cubes tested
$Na_2O$	Sodium Oxide
$SiO_2$	Silica Oxide
$TiO_2$	Titanium Oxide



$V$	Absolute volume
$W$	Water content in kg
$W_c$	Water cement ratio

## **DEFINITIONS**

- Absorption:** The process by which a liquid is drawn into and tends to fill permeable pores in a porous solid body; also, the increase in mass of a porous solid body resulting from the penetration of a liquid into its permeable pores.
- Admixture:** Material other than water, aggregates, hydraulic cementitious material, and fibre reinforcement that is used as an ingredient of a cementitious mixture to modify its freshly mixed, setting, or hardened properties and that is added to the batch before or during its mixing.
- Aggregate:** Granular material, such as sand, gravel, crushed stone, or iron blast-furnace slag, used with a cementing medium to form hydraulic-cement concrete or mortar.
- Ceramics:** Brittle solids that are suitable for withstanding very high temperatures.
- Coarse aggregate:** Aggregate predominantly retained on the 4.75-mm (no. 4) sieve; or that portion of an aggregate retained on the 4.75-mm (no. 4) sieve.
- Fine aggregate:** Aggregate passing the 9.5-mm sieve and almost entirely passing the 4.75-mm (no. 4) sieve and predominantly retained on the 75- $\mu$ m (no. 200) sieve; or that portion of

an aggregate passing the 4.75-mm (no. 4) sieve and retained on the 75- $\mu$ m (no. 200) sieve.

**Bulk density:** The mass of a unit volume of bulk aggregate material (the unit volume includes the volume of the individual particles and the volume of the voids between the particles).

**Concrete:** Composite material that consists essentially of a binding medium within which are embedded particles or fragments of aggregate; in hydraulic-cement concrete, the binder is formed from a mixture of hydraulic cement and water.

**Consistency:** The relative mobility or ability to flow of fresh concrete, mortar, or grout.

**Curing:** Action taken to maintain moisture and temperature conditions in a freshly-placed cementitious mixture to allow hydraulic cement hydration and (if applicable) pozzolanic reactions to occur so that the potential properties of the mixture may develop

**Density:** Mass per unit volume (preferred over deprecated term unit weight)

Fineness modulus:	Factor obtained by adding the percentages of material in the sample that is coarser than each of the following sieves (cumulative percentages retained), and dividing the sum by 100: 150- $\mu\text{m}$ (no. 100), 300- $\mu\text{m}$ (no. 50), 600- $\mu\text{m}$ (no. 30), 1.18-mm (no. 16), 2.36-mm (no. 8), 4.75-mm (no. 4), 9.5-mm, 19.0-mm, 37.5-mm, 75-mm, 150-mm.
Fresh concrete:	Concrete which possesses enough of its original workability so that it can be placed and consolidated by the intended methods.
Maximum size:	In specifications for, or description of aggregate, the smallest sieve opening through which the entire amount of aggregate is required to pass.
Nominal maximum size:	In specifications for, or description of aggregate, the smallest sieve opening through which the entire amount of the aggregate is permitted to pass.
Pozzolan:	A siliceous or siliceous and aluminous material, which in itself possesses little or no cementitious value but will, in finely divided form and in the presence of moisture, chemically react with calcium hydroxide at ordinary temperatures to form compounds possessing cementitious properties.

Rate analysis:	The process of fixing cost per unit of measurement for the different item of works.
Sand:	Fine aggregate resulting from natural disintegration and abrasion of rock or processing of completely friable sandstone.
Segregation:	The unintentional separation of the constituents of concrete or particles of an aggregate, causing a lack of uniformity in their distribution.
Setting:	The process, due to chemical reactions, occurring after the addition of mixing water, that results in a gradual development of rigidity of a cementitious mixture.
Specific gravity:	The ratio of mass of a volume of a material at a stated temperature to the mass of the same volume of distilled water at a stated temperature.
Time of setting:	The elapsed time from the addition of mixing water to a cementitious mixture until the mixture reaches a specified degree of rigidity as measured by a specific procedure.
Unit weight:	Mass per unit volume. (deprecated term—use preferred term bulk density) of aggregates.

Water-cement ratio: The ratio of the mass of water, exclusive only of that absorbed by the aggregates, to the mass of Portland cement in concrete, mortar, or grout, stated as a decimal.

Workability of concrete: That property determining the effort required to manipulate a freshly mixed quantity of concrete with minimum loss of homogeneity.

## **ABSTRACT**

The increased demand for construction over the past two decades has led to drastic increase in the cost of concrete production. The increasing cost and scarcity of Portland cement has impacted negatively on the delivery of affordable housing and infrastructural development in developing countries like Uganda. For this reason, there is urgent need for finding suitable alternatives which can replace cement partially or at a high proportion. This study focussed on establishing the feasibility of using crushed ceramic and porcelain clay tiles powder as partial replacement of cement in production of eco-friendly concrete. Samples of ceramic and porcelain clay tiles were taken in accordance to BS 1881-101: 1983, which gives methods of sampling. Fifty kilograms of each material was picked from each of the 20 sampled sites within Kampala metropolitan area. X-Ray Fluorescence Spectrometer method was used to determine the chemical composition of the ceramic and porcelain clay tile powders while the physical properties were determined using the ASTM C187 and ASTM C188. A comparison between the properties of the waste materials and cement was made to verify if its composition warrants it to be used as a pozzolan. Concrete cubes measuring 150 mm × 150 mm × 150 mm and 100 mm × 200 mm cylinder specimens were made from seven different concrete mixes prepared by using crushed ceramic and porcelain clay tile powder to replace 0, 5, 10, 15, 20, 25 and 30% of ordinary Portland cement (grade 42.5) by mass. The workabilities of the fresh concrete mixes were evaluated using the slump test while compressive and splitting tensile strengths of hardened concrete were evaluated at different curing periods of 7, 14 and 28 days. The Civil Engineering Standard Method of Measurement was used to evaluate the cost of concrete production. Two indicators (abiotic depletion and global warming) were

used to evaluate the environmental impacts. The properties of ceramic and porcelain powders showed that the combined percentage of silica, iron oxide, and alumina for both materials met the 70% minimum requirement of ASTM C 618 for a good pozzolan. The results of slump test showed that increase in ceramic and porcelain powder replacement decreased the workability of concrete. Replacement of cement with ceramic and porcelain powder significantly increased the compressive strength of concrete. The target compressive and tensile splitting strengths were achieved up to 20% replacement of cement with ceramic and porcelain powder beyond which the strength reduced. The cost evaluation indicated there was a reduction of 15.2% between the conventional and optimal mixes. Energy consumption reduced by 12.8%, signifying a reduction in the production cost of binders. Finally, carbon dioxide emission reduced by 19.2% implying a significant reduction in global warming.



## CHAPTER ONE

### INTRODUCTION

#### 1.1 Background to the Study

The construction industry constitutes one of the main contributors to the economy of any country. In fact, it contributes about 10% of the gross domestic product (GDP) in the world. The industry plays a huge role in not only economic development but also improving the welfare of the citizens. Over the past two decades, the rate of growth in construction has increased drastically from 1.8% globally with the largest contributors to the construction market being Europe, America, Asia and Japan as they control more than 70% of the industry (Wadel, 2009). The industry is forecasted to grow at a rate of 4.2% from 2018 to 2023. The major drivers for the growth of this market are increasing housing starts and rising infrastructure due to increasing urbanization and growing population. Emerging trends which have a direct impact on the dynamics of the construction industry include increasing demand for green construction to reduce carbon footprint. (Ikponmwosa *et al.*, 2017).

Concrete is the world's most utilized construction material and due to this, statistics have shown that worldwide cement production, by major producing countries from 2011 to 2016 has drastically increased and so has its cost (Xi *et al.*, 2016). Global cement production is expected to increase from 3.27 million metric tons in 2010 to 4.8 million metric tons in 2030. Yet, due to the increase in demand of construction, the cost of concrete production has become more expensive over the years and is expected to increase even further. This has resulted in increased initiatives to modify ordinary concrete to make it more sustainable and affordable so as to cater for the increasing

construction boom. Consequently, properties of concrete such as strength, workability and durability of concrete have opened avenues for new innovations in the production of concrete.

In this regard, different studies have been done on the reduction of the cost of concrete production like replacing cement with: animal blood, waste glass powder, rice husk ash, saw dust, steel shot dust, and using kiln saw dust among others (Prabagar *et al.*, 2015). Interest has been driven much towards these wastes and recycled materials as they are economical and more environmental friendly. Particularly, ceramic materials which include brick walls, ceramic tiles and all the ceramic products contribute the highest proportion of wastes in the construction and demolition waste (Meena, 2017). Ceramic waste can be used in concrete to increase its strength and other durability factors. Ceramic waste can be used to partially replace cement or sand in order to achieve different properties of concrete as noted by Raval (2013).

The production of ceramic tiles is unique in that they stand out for its low water absorption and high mechanical strength. The properties of ceramic clay tiles result from its low porosity due to the processing conditions such as high degree milling of raw materials, high force compaction and sintering temperature among others, and the potential of the raw materials to form liquid phases during sintering (high desiccation). On the other hand, porcelain tile is a type of ceramic material which possesses high vitreous characteristics. This vitrification indicates that it has a high degree of melting on firing and this improves on its mechanical strength (Perez *et al.*, 2013).

In reference to these increasing prices of cement over the years, there is a concern to reduce total cost of concrete production. Since the cost of cement as a binder is constantly increasing, the cost of concrete production will be high. This study aimed at finding alternatives of reducing the cost of concrete production for low cost housing construction by use of waste ceramic and porcelain clay tiles as partial replacement of cement during production of concrete.

## **1.2 Statement of the Problem**

The increased demand of construction over the past two decades has led to drastic increase in the cost of concrete production. Worldwide, the annual production of concrete is estimated to be approximately 4 million tons of concrete. Such volumes require vast amounts of natural resources for concrete ingredients such as aggregate and especially cement production. Specifically, the cost of building materials such as cement, granite and aggregates continue to increase and this poses a great challenge to most constructors. The world's cement market currently stands at approximately 2 million tonnes of cement, 80% of which is consumed in emerging countries like Uganda. Demographic growth, urbanization and economic growth are generating annual growth of 5% (100 million tonnes) in this market (Lafarge, 2007).

Additionally, the growing concern of depletion of resources necessitates the search for alternatives sources (Agbede *et al.*, 2009). Due to this increase and varying costs of materials for production of concrete, there is need for alternative material to be blended with cement in order to reduce the cost of concrete (Naik *et al.*, 2003). Recently, a surge in the price of cement has led to a crisis in the construction industry in Uganda

and this resulted into panic buying, hoarding and rationing as was reported by retailers and consumers. The falling production in Tororo Cement and Hima Cement manufacturing plants was attributed to reduced electricity supplies. Morgan Gagranihe, the executive director of Tororo Cement, said that production from the company's plant at Tororo had fallen by half to 0.6Mt/year from 1.2Mt/year, according to the Daily Monitor newspaper of 6<sup>th</sup> April 2018.

In addition, as much as 50% of all materials extracted from the earth's crust are transformed into construction materials and products and this contributes greatly to abiotic depletion (Arpad, 2004). Not only that but also Portland cement production is very energy-intensive and so, from the standpoint of conservation of natural resources as well as energy saving, the use of alternative waste constituents in construction materials is now a global concern. For this reason, extensive research and development works towards exploring new ingredients are required for producing adequate, sustainable and environment friendly construction materials. There have been numerous attempts to utilize ceramic wastes in the manufacture of wall and floor ceramic tiles in the last two decades, reusing ceramic wastes in the manufacture of vitrified sewer pipes, and manufacture of mortar (Meena, 2017).

Furthermore, it has also been estimated that the production of one ton of Portland cement causes the release of approximately one ton of carbon dioxide (CO<sub>2</sub>) into the atmosphere. CO<sub>2</sub> is a greenhouse gas and it is consequently responsible for global warming. The cement industry alone generates about 7% of the world total carbon dioxide emission.

According to Ganesan (2000), construction materials account for the largest input into construction activities, in the range of 50-60% of the total project cost. Unfortunately, large portions of construction materials are transformed into waste and hence not wholly utilized by the industry. Evidence shows that approximately 40% of the waste generated globally originates from the construction and demolition of buildings (Holm, 1998) and this forms a major portion of the solid waste generally discarded in landfills worldwide. It is a common practice in Uganda that during cost estimations for construction materials, estimators add 5% extra materials to cater for wastes in the course of construction activities. This shows that during planning and design stages, there is lack of consideration given to waste reduction to minimize the generation of waste (Muhwezi *et al.*, 2012).

Consequently, efforts have been made in the concrete industry to use waste such as ceramics among others as partial replacement materials. The demolition and disposal of wastes generated from concrete structures, pavements, etc., constitutes additional environmental burden. Construction debris contributes a large fraction of solid waste disposal problem, with concrete structures constituting the largest single component. Ceramic products like tiles and sanitary ware are part of the essential construction materials used in most building works especially as finishes. Some common manufactured ceramics include wall tiles, floor tiles, sanitary ware, household ceramics and technical ceramics (Prabagar *et al.*, 2015). They are mostly produced using natural materials that contain high content of clay minerals. Despite the ornamental benefits of ceramics, its waste causes a lot of nuisance to the environment.

Efforts have been made in Uganda to re-use the tile for reconstruction in the case of unbroken ones, others use them as hard core for base construction, and companies that recycle these tiles barely exist. Despite the above measures in tile waste management, little effort has been done in studying the use of ceramic tiles in concrete production in terms of its powder. Understanding this is imperative in going a long way in ensuring that the tile wastes from the construction sites are utilized and are of economical use. This study aimed at addressing this through establishing the feasibility of partial replacement of cement with waste ceramic and porcelain tile powder in concrete production.

Conclusively, these points and these numbers seem to indicate that the concrete industry has become a victim of its own success and therefore is now faced with tremendous challenges. But the situation is not as bad as it might seem, because eco-friendly concrete is inherently an environmentally friendly material, as can be demonstrated readily with a life-cycle analysis (Geem, 2002). The challenges derive primarily from the fact that Portland cement is not environmentally friendly to the problems associated with use of Portland cement could be solved by observing the simple requirement of using as much concrete with as little Portland cement as possible. It is for this reason that my study attempts to use ceramic and porcelain waste in production of environmentally friendly concrete.

### **1.3 Objectives**

#### **1.3.1 General Objective**

The general objective of this study was to assess the suitability of using crushed ceramic and porcelain clay tiles as partial replacement of cement in concrete.

#### **1.3.2 Specific Objectives**

- (1) To determine the engineering properties of crushed ceramic and porcelain clay tile powders.
- (2) To evaluate the performance of concrete mix obtained from using crushed ceramic and porcelain clay tiles as partial cement substitutes.
- (3) To assess the cost-benefit of using crushed ceramic and porcelain clay tiles as partial replacement materials for cement in concrete.

### **1.4 Research Questions**

- (1) Do the engineering properties of crushed ceramic and porcelain clay tile powder warrant it to be used as a pozzolan?
- (2) How does the concrete mix obtained from using crushed ceramic and porcelain clay tiles as partial replacement materials for cement in concrete perform?
- (3) What is the cost-benefit of using crushed ceramic and porcelain clay tiles as partial replacement materials for cement in concrete?

### **1.5 Justification**

The evident relatively high cost of cement (currently (USD 14) per 50 kg bag), and yet it is the major concrete constituent. This calls for research in order to find an alternative

to partially or fully replace cement. Utilization of wastes from other industries as building materials is one of the sustainable measures that the construction industry can adopt. This will lead to reduced cost of concrete production and consequently reduced cost of construction which in turn leads to affordable housing construction.

There is continuous demolition of old structures around Kampala and reconstruction. Other demolished components like bricks, air vents and aggregates have been re-put into use after proper removal but tiles from the old structures have been abandoned in stores or broken tiles are often heaped on sites, reused and disposed to dumping grounds or buried and forgotten until when they manifest in increased waste levels. Tile waste is a major problem for construction industries, manufacturing industry, sites where they are sold and homesteads worldwide. This study, therefore, focussed on utilizing old waste tiles from demolished structures in order to reduce waste around Kampala.

The production of cement requires high energy input (850 kcal per kg of clinker) implying that the extraction of large quantities of raw materials from the earth requires several tons of rock to produce 1 ton of clinker. Not only does the production of one ton of cement generate 0.55 ton of chemical CO<sub>2</sub> but also requires an additional 0.39 ton of CO<sub>2</sub> in fuel emissions, accounting for a total of 0.94 ton of CO<sub>2</sub>, which is a greenhouse gas responsible for global warming.

Conclusively, in today's world, concrete constitutes the most popular material in construction in both the developed and the developing countries (Chee *et al.*, 2011).



Therefore, not only are the economic and technical aspect of concrete important, but also is its conservation and energy consumption. Due to the increase in price of cement used in concrete production, finding alternatives to reduce the amount of cement required is thus very desirable (Pacheco, 2010).

## **1.6 Scope and Limitations**

### **1.6.1 Scope of the Study**

Ceramic and Porcelain clay tile waste was sampled from Kampala and its environs, targeting construction sites, areas of Kireka sites that sell tiles, Namave where many tile producers are available, Bukoto as an area of major demolition and Namugongo area undergoing a lot of construction. The study involved homesteads undergoing massive demolition due to the recent road development programs in Kampala city like along northern by pass. Next, the engineering properties of ceramic and porcelain clay tiles was limited to physical properties and chemical composition respectively determined using the relevant standards and X-Ray Fluorescence Spectrometer.

Further, the performance of concrete with ceramic and porcelain clay tile powder as partial cement substitute was evaluated from the properties of fresh concrete (workability) as well as the properties of hardened concrete (compressive strength and splitting tensile strength) monitored at 7, 14 and 28 days of curing. Based on the reviewed literature, several authors have utilized ceramic waste whilst others have investigated the use of porcelain waste as partial replacement of cement in concrete and obtained similar results. The two powders were therefore mixed in ratio of 1:1. It was on this basis that this study did not seek to find the individual effect of each waste

material in the concrete mixes. However, the engineering properties of both ceramic and porcelain powders were determined to verify similarities as well as warrant their use as pozzolan.

Finally, the cost benefit of using crushed ceramic and porcelain clay tiles as partial replacement materials for cement in concrete was limited to comparing the performance and cost of optimal mix with the conventional mix. The benefits in terms of the environment were also evaluated. This was assessed to determine the suitability of using crushed ceramic and porcelain clay tiles as partial replacement materials for cement in concrete production for low cost housing construction.

### **1.6.2 Limitations**

First and foremost, there was lack of instrumentation for determination of all the chemical components of the ceramic and porcelain powders. This was a limitation because sodium oxide content could not be determined due to lack of Atomic Absorption Spectrophotometry (AAS) and Flame Emission Spectrophotometry (FES), or flame photometry which are approved standard methods for determination of sodium composition and potassium content in materials for making concrete. Flow Injection Analysis (FIA) which initially was intended to be incorporated to these detectors in order to gain various advantages like fast and convenient operation and high degrees of automation was also unavailable. In spite of this limitation, alternative methods used included slump test to monitor workability and X-Ray fluorescence spectrometer to determine the chemical composition.

## **CHAPTER TWO**

### **LITERATURE REVIEW**

#### **2.1 Introduction**

This chapter involves the theories upon which this research is based as well as the empirical review of existing related research that has already been carried out in this field of concrete production. It is organized starting with theoretical literature followed by empirical literature review. A critique of existing literature is also presented and the research gap identified to warrant the contribution of this research study to knowledge. In a nutshell, this chapter gives an orientation to the research problem by referencing to previous concepts/theories and researches related to this particular area of study.

#### **2.2 Theoretical Review**

##### **2.2.1 Concrete**

Concrete is a manmade construction material that looks like stone. The word “concrete” is derived from the Latin *concretus*, meaning “to grow together.” Concrete is a composite material composed of several ingredients such as coarse granular material (aggregate) embedded in a hard matrix of material (the cement or binder) that fills the space among the aggregate particles thereby gluing them together. Alternatively, one can say that concrete is a composite material that constitutes essentially of a binding medium in which are embedded particles or fragments of aggregates either fine or coarse. Concrete is a composite material composed of gravels or crushed stones (coarse aggregate), sand (fine aggregate) and hydrated cement or binder (Neville *et al*, 1995).

A variety of new materials in the field of concrete technology have been developed during the recent past with the ongoing demand of construction industries to meet the functional, strength, economical and durability requirements. Concrete is the most widely used material in the world. It contributes an important fraction in the infrastructure and private buildings construction industry. Concrete can be named in different ways depending on the various kinds of binding material used. For example, if a concrete made of hydraulic cement, it is called hydraulic cement concrete; if a concrete is made with non-hydraulic cement, it is called non-hydraulic cement concrete; if a concrete is made of asphalt, it is called asphalt concrete; if a concrete is made of polymer, it is called polymer concrete. The similarity is that both non-hydraulic and hydraulic cement require water to mix in and react during their hydration process. However, their individual ability to gain strength in water forms the main difference between the two types of cement. Non-hydraulic cement cannot gain strength in water, while hydraulic cement does (Li, 2011).

Fresh concrete mix should be consistent in such manner that it can be compacted easily by the desired manner without excessive effort, this' a property broadly referred to as workability. Workability as defined by Japanese Association of Concrete Engineers is that property of concrete or mortar that determines the ease and homogeneity with which it can be mixed, placed and compacted due to its consistency, the homogeneity with which it can be made into concrete, and the degree with which it can resist separation of materials. Workability of fresh concrete is dependent on concrete properties especially the water to cement ratio. Excessively dry mixes have low workability hence difficult to compact and this may lead to poorly compacted concrete

results in presence of voids which greatly reduces its strength. The workability of fresh concrete can be determined by a simple, inexpensive and relatively accurate test referred to as the slump test which is fully described in BS 1881:102:2011.

The primary requirement of concrete in its hardened state is satisfactory compressive strength and durability. The strength of concrete is often considered its most important property and is used as a basis to determine the quality of concrete. This is vital since it is the element ultimately considered in structural design. Test for compressive strength is done by crushing cast concrete cubes made according to specifications contained in BS 1881:115:2011. The strength of concrete is greatly influenced by two factors namely the water/cement ratio and the degree of compaction (Odero, 2015).

### **2.2.2 Classification of Concrete**

#### **(a) Classification in accordance with unit weight**

According to the unit weight of concretes, they can be classified into four categories, as shown in Table 2.1. Ultra-lightweight concrete is only appropriate for use in building non-structural members. Lightweight concrete can be used to build both non-structural and structural members, depending on its specified composition. The commonly used concretes in the construction of infrastructures and buildings is Normal-weight concretes. In building some special structures, such as hospital examination rooms, laboratories, and nuclear plant, where radioactive protection is needed to minimize its influence on people's health, heavyweight concrete is considered most appropriate for use (Li, 2011).

Table 2.1: Classification of concrete in accordance with unit weight

Classification	Unit Weight (kg/m <sup>3</sup> )
Ultra-light weighted concrete	< 1200
Light-weight concrete	1200 < Unit Weight < 1800
Normal-weight concrete	1800 < Unit Weight < 2400
Heavy-weight concrete	2400 < Unit Weight < 3200

Source: (Li, 2011)

**(b) Classification in accordance with compressive strength**

According to its compressive strength, concrete can be classified into four categories, as listed in Table 2.2 (El-Reedy, 2009). Low strength concrete is mainly used to construct mass concrete structures, subgrades of roads, and partitions in buildings. The most commonly used concrete in buildings, bridges, and similar structures is the moderate strength concrete. High strength concretes can be used to build tall building columns, bridge towers, and shear walls. Ultra-high strength concretes have not yet been widely used in construction of structures except in a few footbridges and some structural segments, such as girders (Li, 2011).

Table 2.2: Classification of concrete in accordance with compressive strength.

Classification	Compressive strength (MPa)
Low strength concrete	< 20
Moderate strength concrete	20 – 50
High strength concrete	50 – 150
Ultra-high strength concrete	> 150

Source: (El-Reedy, 2009)

**(c) Classification in accordance with additives**

According to the materials other than cement, aggregate and water that are added into concrete mixtures as additives, concretes can be classified into different categories. Four examples are shown in Table 2.3. Concrete which incorporates fibres is referred to as Fibre-Reinforced Concrete (FRC).

Table 2.3: Concrete classifications in accordance with additives

Classification	Additives
Micro defect free	Polymers
Fibre-reinforced concrete	Different fibres
Densified with small particles concrete	Large amount silica fume
Polymer concrete	Polymers

Source: (Li, 2011)

Many different fibres have been used to produce fibre-reinforced concrete, including steel, glass, polymeric, and carbon. The purpose of incorporating fibres into concrete includes toughness enhancement, tension property improvement, shrinkage control, and decoration (Neville *et al.*, 1995). Macro defect free (MDF) is a cement based composite that incorporates a large amount of water-soluble polymer which is produced in a twin-roll mixing process. This was developed to enhance the flexural and tensile properties of concrete. Concrete that has been densified with small particles (DSP) has incorporated a large amount of silica fume, a mineral admixture with very small particles. DSP has excellent abrasion resistance and is mainly used to produce machine tools and industrial moulds. There are three methods which have been developed to incorporate polymers into concrete. These include using the polymer as a binder, using the polymer as an admixture in ordinary Portland concrete and impregnating the polymer into normal Portland cement concrete members (Li, 2011).

### **2.2.3 Constituent Materials for Making Concrete**

Concrete is one of the most versatile and widely produced construction materials worldwide. Its worldwide annual production exceeds 4 billion metric tons, with more than two metric tons of concrete was produced each year for every person on earth in 2007. The increasing demand for infrastructure development and hence concrete materials is being driven by the ever increasing population, living standards, and economic development. As a composite material, concrete is composed of different graded aggregates or fillers embedded in a hardened matrix of cementitious material. The properties of major constituents of concrete mixtures, such as aggregates, cementitious materials, admixtures, and water, should be understood first to better learn the properties and performance of concrete (Neville *et al.*, 1995).

#### **(a) Cement**

Cement is defined as the material used in preparation of concrete with components which have binding characteristics that contribute towards the strength and durability of the concrete which has been casted (Chee *et al.*, 2011). Cement is used as a binder which sets, hardens independently and binds other materials. Cement is manufactured from four main raw materials namely; lime from limestone, silica from shale, iron oxide and alumina. In the manufacture of cement, limestone is heated with small quantities of the other raw materials to 1450°C in a kiln to form a clinker in the process known as clinkering. The product is then cooled and ground into a fine powder, added some gypsum thus forming the commercial ordinary Portland cement. Portland cement is the most commonly used cement type globally. This is a fine powder which is produced through grinding Portland cement clinker (Ye *et al.*, 2006).



The three main chemical constituents of cement include lime, silica and alumina (El-Reedy, 2009). Additionally, there are minor constituents such as iron oxide, magnesia, sulphur dioxide and alkalis. The constituents are combined in burning and have unique properties of setting and hardening in the presence of water after hydration process. Le-Chatelier and Tornebohm have referred to these compounds as Alite ( $C_3S$ ), Belite ( $C_2S$ ), Celite ( $C_3A$ ) and Felite ( $C_4AF$ ). The following Bogue compounds shown in Table 2.4 are formed during clinkering process. The properties of ordinary Portland cement vary distinctively with the proportions of these compounds (Newman, 2003).

Table 2.4: Compounds in Portland cement

Name Symbol	Principal mineral formula	Compounds in OPC
Tricalcium silicate	$3CaO\_SiO_2$	Alite $C_3S$
Dicalcium silicate	$2CaO\_SiO_2$	Belite $C_2S$
Tricalcium aluminate	$3CaO\_Al_2O_3$	Celite $C_3A$
Tetracalcium aluminoferrite	$4CaO\_Al_2O_3\_Fe_2O_3$	Felite $C_4AF$

Source: (El-Reedy, 2009)

The chemical composition of cement may be tested using X-ray fluorescence of the given sample. This is a non-destructive technique which determines the elements present in cement (Table 2.5). However, the X-ray diffraction technique is used to determine the mineralogical components (chemical composition) present in the Portland clinker gravity. The cement may also be assessed for its specific gravity, burning, adulteration and hydration. An under burnt cement contains large proportion of un-combined, or insufficiently combined elements, some of which are sources of great danger. If such cement is used, these elements may cause disintegration and the ultimate failure of the structure (Neville *et al.*, 1995).

Hydration is the chemical reaction that takes place between cement and water. During the hydration process, the active components of cement ( $C_4AF$ ,  $C_3A$ ,  $C_3S$  and  $C_2S$ ) react with water. The hydration products start depositing on the outer periphery of the nucleus of hydrated cement when the cement comes in contact with water. This reaction proceeds slowly (2 to 5 hours) and is called dormant period or simply induction (Li, 2011).

Table 2.5: Functions of compounds in cement

Compound	Percentage	Purpose
Tricalcium silicate	40	○ Increase resistance to freezing and thawing
		○ Early hardness and strength within 7 days
		○ High heat due to rapid hydration
Dicalcium silicate	32	○ Slow hydration
		○ Add strength after a year or more
		○ Resistance to chemical attack
Tricalcium aluminate	10.5	○ Cause flash set of finely ground clinker
Tricalcium aluminate	9	○ Initial setting
		○ High heat of hydration
		○ Volume changes causing cracking

Source: (El-Reedy, 2009)

As the hydration proceeds, the deposit of hydration products on the original cement grain makes the diffusion of water to un-hydrated nucleus more and more difficult, consequently reducing the rate of hydration with time. At any hydration stage, the cement paste consists of a fine-grained product of hydration having large surface area collectively (gel), the unreacted cement, calcium hydroxide, water and some minor compounds. The reaction mechanism is that crystals of the various resulting

compounds gradually fill the space originally occupied by water, resulting in the stiffening of the mass and subsequent development of the strength (El-Reedy, 2009).

**(b) Aggregates**

The skeleton of concrete is constituted by aggregates since approximately three quarters of the overall volume of conventional concrete is occupied by aggregate. It is therefore inevitable that a constituent occupying such a large percentage of the mass should contribute important properties to both the fresh and hardened product. Aggregate is considered as an inert dispersion in the cement paste. However, strictly speaking, aggregate is not truly inert because physical, thermal, and chemical properties can influence the performance of concrete (Neville *et al.*, 1995).

Aggregates can be divided into several categories according to different criteria, such as size, source, and unit weight. In accordance with size, aggregates predominately retained on a No. 4 (4.75mm) sieve are classified as coarse aggregate. In general, coarse aggregate ranges from 5 to 150mm in size. For normal concrete used for structural members such as columns and beams, the maximum size of coarse aggregate is usually about 25mm whilst mass concrete used for dams or deep foundations constitute of maximum size of 150 mm as largest size. Fine aggregates are classified as those aggregates passing through BS test sieve 4.75mm and predominately retained on BS test sieve 75  $\mu\text{m}$  for instance river sand which is the most commonly used fine aggregate. In addition, crushed rock fines is also used as fine aggregate in spite of the differences in the finishing surfaces for instance the finish of concrete with crushed rock fines is not as good as that with river sand (Ye *et al.*, 2006).

Natural aggregates such as sand and gravel is usually taken from natural deposits without changing the nature during production. Manufactured (synthetic) aggregates are man-made materials, resulting from industrial products or by-products. Blast furnace slag and lightweight aggregate are some of such examples. The unit weight of ultra-lightweight aggregate is less than  $500 \text{ kg/m}^3$ , including foam plastic and expanded perlite. Depending on the volume fraction of aggregate, the bulk density of concrete made from ultra-lightweight aggregates ranges from 800 to  $1100 \text{ kg/m}^3$ . Such a concrete can be used only as non-structural members, like partition walls. The unit weight of light-weight aggregates is between 500 and  $1120 \text{ kg/m}^3$ . Examples include cinder, blast furnace slag, volcanic pumice, and expanded clay. The concrete constituting lightweight aggregate has a bulk density between 1200 and  $1800 \text{ kg/m}^3$ . Such concrete can be either a structural member or non-structural member, depending what type of aggregate is used. Sand, gravel, and crushed rock belong to the category of aggregate with a unit weight of  $1520\text{--}1680 \text{ kg/m}^3$  classified as normal-weight aggregate and are most widely used. Concrete made with normal-weight aggregate of aggregate has a bulk density of  $2300\text{--}2400 \text{ kg/m}^3$ . It is the main type of concrete used to produce critical structural members. If the unit weight of aggregate is greater than  $2100 \text{ kg/m}^3$ , it is classified as heavy-weight aggregate. Materials used include iron ore, magnesite limonite and crashed steel pieces among others. The bulk density of the corresponding concrete is consequently greater than  $3200 \text{ kg/m}^3$  and can reach  $4000 \text{ kg/m}^3$  (Li, 2011).

**(c) Water**

Water is such an important constituent of concrete, and a properly designed concrete mixture, typically with approximately 15 to 25% water by volume, possess the desired workability for fresh concrete and the required durability and strength for hardened concrete. The primary role of water is for hydration and workability. The total amount of water in concrete and the water-to-cement ratio is one of the most critical factors in the production of quality concrete. Too much water reduces concrete strength, while too little makes the concrete unworkable thereby calling for a balance in the amount of water required for mixing concrete. Because concrete must be both strong and workable, a careful selection of the cement-to-water ratio and total amount of water are required when producing concrete. Water can exist in a solid form as ice, a liquid form as water, or a gaseous form as vapour. Mixing water is the free water encountered in freshly mixed concrete. It has three main functions: it acts as a lubricant, contributing to the workability of the fresh mixture; it reacts with the cement powder, thus producing hydration products; and finally, it secures the necessary space in the paste for the development of hydration products. Because of this obvious reason, the amount of water added for adequate workability is always greater than that needed for complete hydration of the cement in practice (Neville *et al.*, 1995).

Unlike other raw materials, the supply of raw water varies significantly in quality, both geographically and from season to season for instance water derived from an upland surface source usually has a low content of dissolved solids and is relatively soft with a high concentration of organic contamination, much of it being colloidal. By contrast, underground water sources generally have a high content of dissolved solids and a high

hardness level but a low organic content. There is a simple rule concerning the acceptability of mixing water: if water is potable, that is, fit for human consumption, with the exception of certain mineral waters and water containing sugar, it is also suitable for concrete making. In other words, if water does not have any particular taste, odour, or colour, and does not fizz or foam when shaken, then there is no reason to assume that such water will hurt the concrete when used properly as mixing water (Bungey *et al.*, 1995).

#### 2.2.4 Desirable Properties of Concrete

##### (a) Characteristic material strength

The strengths of materials upon which a design is based, normally, those strengths below which results are unlikely to fall are called ‘characteristic’ strength. The assumption is that for a given material, the distribution of strength is approximately ‘normally distributed’, so that a frequency distribution curve of a large number of sample results would be of the form shown in Figure 2.1. The characteristic strength,  $f_k$  is taken as that value below which it is unlikely that more than 5% of the results will fall as expressed by Equation (2.1). In the equation,  $f_m$  is mean strength given by Equation (2.2);  $\sigma$  is standard deviation and is a measure of quality control given by Equation (2.3) where  $f$  is the cube strength, and  $n$  is number of cubes tested.

$$f_k = f_m - 1.64\sigma \quad (2.1)$$

$$f_m = \frac{\sum f}{n} \quad (2.2)$$

$$\sigma = \left[ \frac{\sum (f - f_m)^2}{n} \right]^{1/2} \quad (2.3)$$

The relationship between characteristic and mean values accounts for variations in results of test specimens and will, therefore, reflect the method and control of manufacture, quality of constructions, and nature of the material.

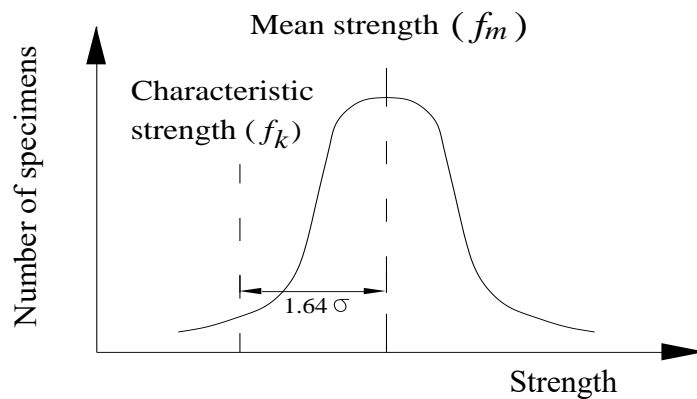

Figure 2.1: Normal frequency distribution of strengths.

Source: (Chanakya, 2009)

**(b) Compressive strength of concrete**

The design rules in EC 2 (Clause 3.1) are based on the characteristic (5%) compressive cylinder strength of concrete at 28 days ( $f_{ck}$ ). The equivalent cube strengths ( $f_{ck, cube}$ ) are included in EC 2 but they are only regarded as an alternative method to prove compliance. The quality of concrete is described by characteristic cylinder strength/characteristic cube strength, e.g., C30/37. In the UK, compressive stress has also been measured and expressed in terms of 150 mm cube crushing strength at an age of 28 days. Most other countries use 150 mm diameter cylinders which are 300mm long. For normal strength concrete, the cylinder strength is equal to 0.8 of the cube strength. This approximation is represented by Equation (2.4). In the equation,  $f_{ck}$  is the characteristic compressive cylinder strength and  $f_{ck, cube}$  is the equivalent characteristic cube strength at 28 days.

$$f_{ck} \approx 0.8 \times f_{ck,cube} \quad (2.4)$$

Any unusual features in the type of failure shall be recorded when determining the compressive strength of concrete cubes. Examples of satisfactory failures and of some unsatisfactory failures are as shown in Figure 2.2. For satisfactory failures, it should be noted that all four exposed faces are cracked approximately equally, generally with little damage to faces in contact with the platens as seen in Figure 2.2.

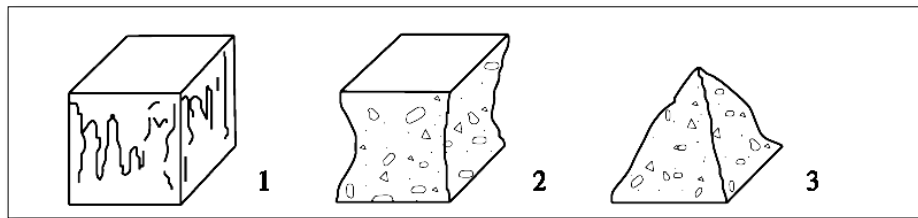

Satisfactory Failures

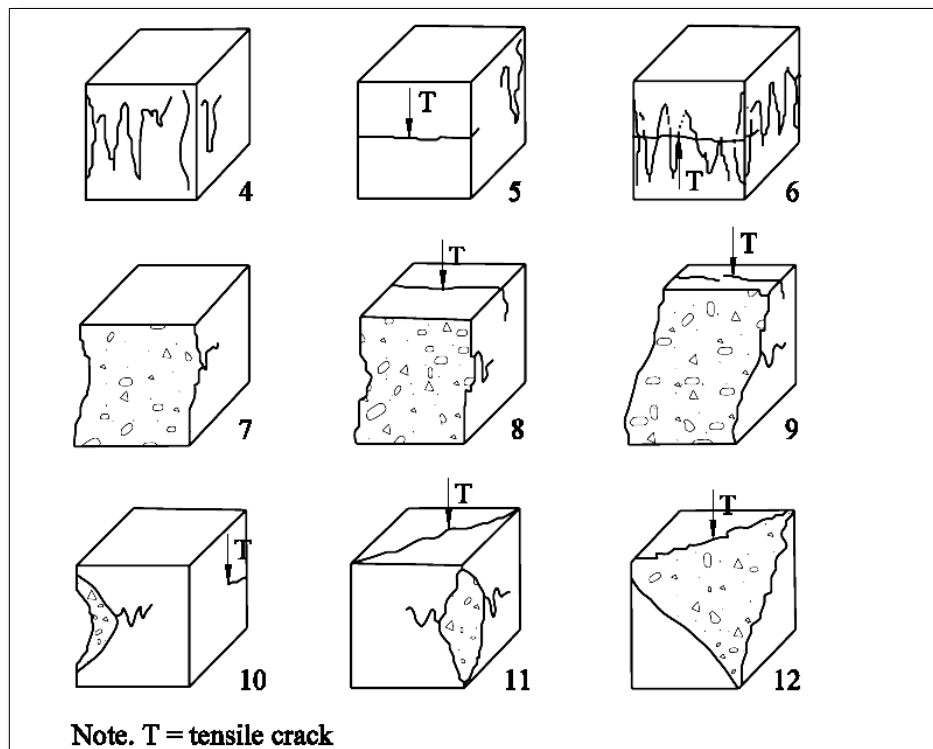

Unsatisfactory Failures

Figure 2.2: Failure patterns of cubes.

Source: (BS 1881-115:2011)



The cross-sectional area of the cube is calculated from the measured dimensions. The compressive cube strength of concrete is calculated by dividing the maximum load by the cross-sectional area, expressed to the nearest 0.1 MPa. The density of the specimen can be calculated using the measured dimensions or the volume obtained from the water displacement method.

**(c) Splitting tensile strength of concrete**

The maximum stress the concrete can withstand when subjected to uniaxial tension (tensile force applies in one axis) is known as tensile strength of concrete. The mean tensile strength  $f_{ct,k}$  of concrete may be derived from Equations (2.5) to (2.7). In the equations,  $f_{ctm}$ ,  $f_{ck}$ ,  $f_{ctk\ 0.05}$ ,  $f_{ctk\ 0.95}$  are the mean tensile strength, characteristic compressive strength, lower characteristic compressive strength at 5% fractile and upper characteristic compressive strength at 95% fractile, respectively

$$f_{ctm} = 0.3 \times f_{ck}^{(2/3)} \text{ N / mm}^2 \quad (2.5)$$

$$f_{ctk\ 0.05} = 0.7 \times f_{ctm} \text{ N / mm}^2 \quad (2.6)$$

$$f_{ctk\ 0.95} = 1.3 \times f_{ctm} \text{ N / mm}^2 \quad (2.7)$$

BS 1881 Part 117 (2011) gives the method for determination of tensile splitting strength. Test specimens are cured in mist chamber or under water and are tested within one hour of removal from the chamber or water, whilst they are still wet. The bearing surfaces of the steel loading pieces, the testing machine, and the packing strips are wiped clean; all loose material on the surfaces of the test specimen which are to be in contact with the packing strips are also removed. The test specimen is then placed in

the centring jig. Packing strips and loading pieces carefully positioned along the top and bottom of the plane of loading of the specimen. The jig is then placed in the machine so as to centrally locate the test specimen. The upper platen is parallel to the lower platen (Figure 2.3).

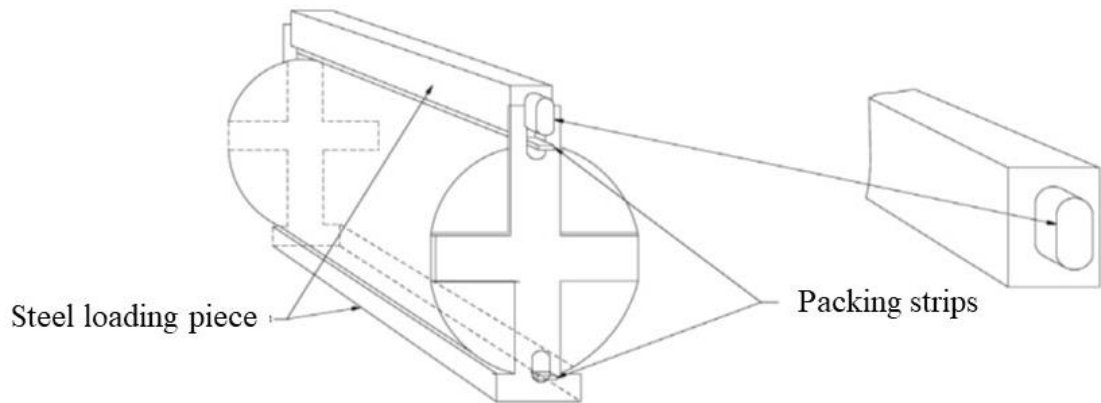
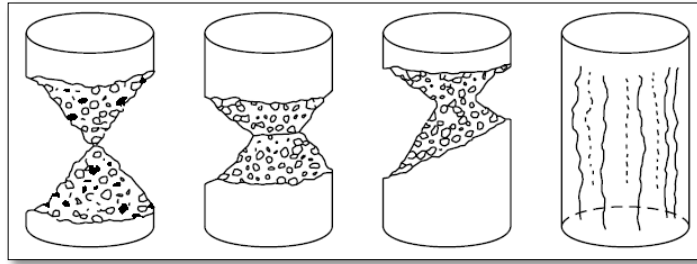

Figure 2.3: Splitting tensile strength specimen.

Source: (BS 1881-117:2011)

The load is applied steadily and without shock such that the stress is increased at a rate within the range of 0.04 MPa/s to 0.06 MPa/s. Once adjusted, the rate is maintained at  $\pm 10\%$  until failure. The maximum load applied to the specimen is recorded. The failure modes of the test cylinders are elaborated in Figure 2.4.



Satisfactory failure of cylinder specimen

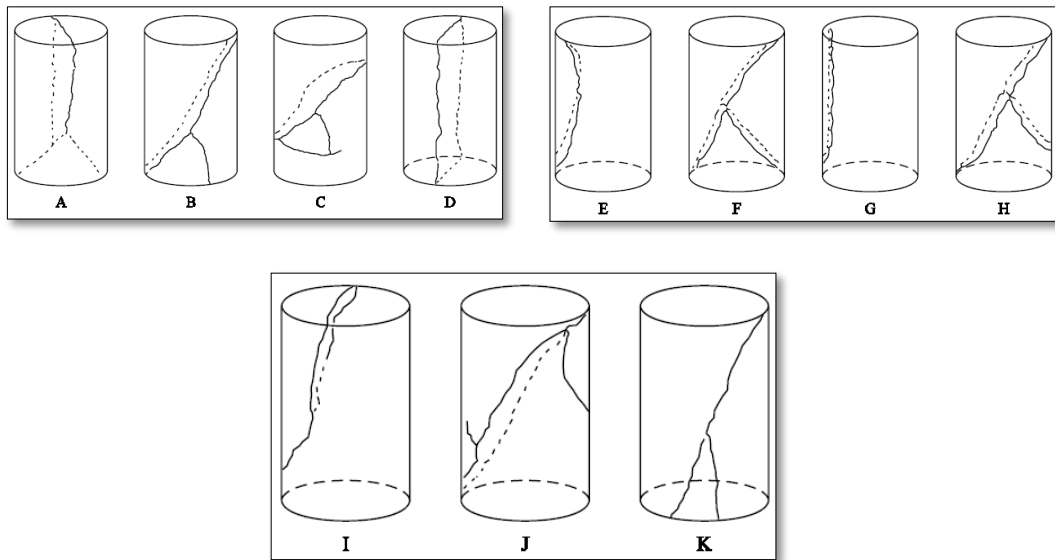

Some unsatisfactory failures of cylinder specimen

Figure 2.4: Failure patterns of cylinders.

Source: (BS 1881-117:2011)

Table 2.6 shows concrete strength classes, characteristic compressive strength  $f_{ck}$  (cylinders), mean tensile strength  $f_{ctm}$ , and characteristic tensile strength  $f_{ctk}$  (in  $N/mm^2$ ). The values given in the table are based on Table 3.1 of Euro code 2.

Table 2.6: Actual strength classes commonly used in reinforced concrete design

Strength Class	C12/15	C16/20	C20/25	C25/30	C30/37	C35/45	C40/50	C45/55
$f_{ck}$	12	16	20	25	30	35	40	45
$f_{ck,cube}$	15	20	25	30	37	45	50	55
$f_{cm}$	1.6	1.9	2.2	2.6	2.9	3.2	3.5	3.8
$f_{ctk0.05}$	1.1	1.3	1.5	1.8	2.0	2.2	2.5	2.7
$f_{ctk0.95}$	2.0	2.5	2.9	3.3	3.8	4.2	4.6	4.9

Source: (Table 3.1, Euro code 2)

#### (d) Flexural strength

Flexural strength is the theoretical maximum tensile stress reached in the bottom fibre of a test beam during a flexural strength test. According to BS EN 123-5:2009, test specimens of 150 mm × 150 mm × 750 mm long moulded concrete beams are stored in water or a mist chamber and tested within one hour of removal from the water or mist chamber, whilst they are still wet. The bearing surfaces of the supporting and loading rollers are wiped clean and loose grit or other extraneous materials are removed from the specimen before being correctly centred in the machine with the trowelled surface vertical (BS EN 123-5:2009).

The rollers are placed at right angles to the longitudinal axis of the specimen after which all loading and supporting rollers are in even contact with the test specimen before load is applied. After the application of the initial load, which does not exceed approximately 20% of the failure load, test load is gradually applied (without shock) such that the stress is increased continuously within the range of 0.04 to 0.06 MPa/s at a determined constant rate of ± 10 %. The test load is applied until no greater load can

be sustained by the test specimen. Once adjusted, the rate of loading is maintained without change until failure occurs. The maximum load applied is recorded. Failures outside the middle one-third of the distance between the supporting rollers shall render the test invalid (Newman *et al.*, 2003).

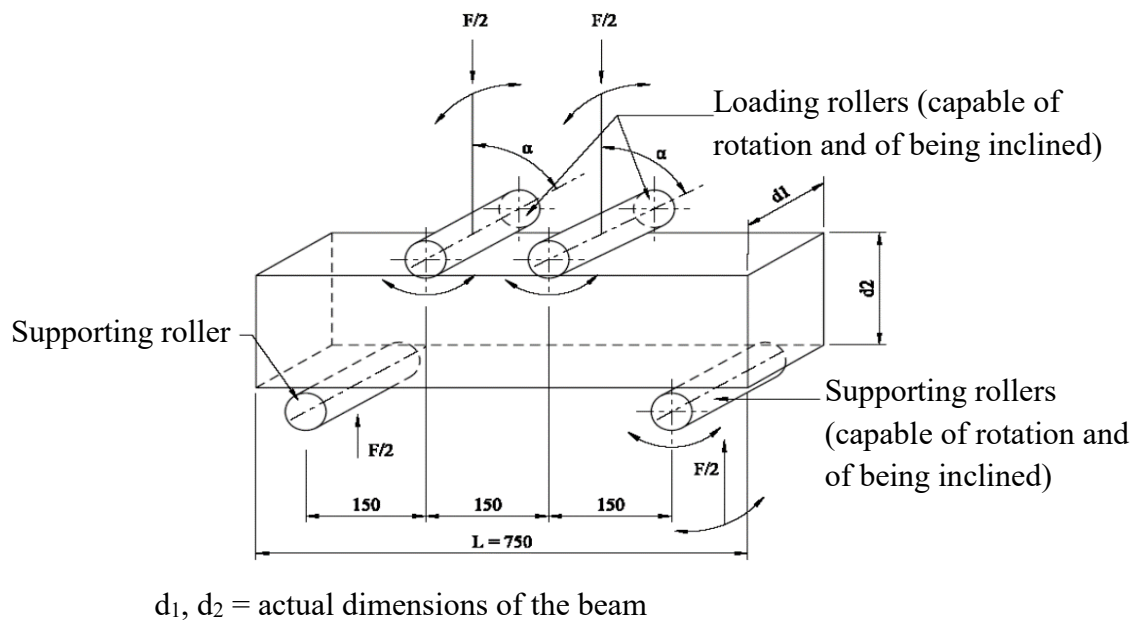

Figure 2.5: Flexural strength beam setup.

Source: (BS EN 123-5:2009)

The flexural strength is determined using Equation (2.8), in which  $f_{cf}$  is the flexural strength in MPa,  $F$  is the maximum load in N,  $L$  is the distance in mm between the supporting rollers,  $d_1$  and  $d_2$  are the lateral dimensions in mm of the cross section.

$$f_{cf} = \frac{3 \times F \times L}{2 \times d_1 \times d_2^2} \quad (2.8)$$

Flexural strength is a measurement that indicates the resistance of a material to deformation when placed under a load. The values needed to calculate flexural strength are measured by experimentation, with rectangular samples of the material placed under load in a 2-point loading testing setup. The average value of 2 specimens for

each category at the age of 7 days, 14 days and 28 days are determined accordingly (Sivaprakash *et al.*, 2016).

**(e) Stress-strain relationship of concrete**

Concrete being a very variable material has a wide range of strengths and stress-strain curves. The stress/strain diagram for concrete subject to uniaxial compression for typical for a short-term loading is shown in Figure 2.6. As the load is applied, the ratio between the stresses and strains is approximately linear at first and the concrete behaves almost as an elastic material with virtually a full recovery of displacement if the load is removed. Eventually as the load is increased, the curve is no longer linear and the concrete behaves more and more as a plastic material. If the load were removed during the plastic range the recovery would no longer be complete and a permanent deformation would remain. The ultimate strain for most structural concretes tends to be a constant value of approximately 0.0035, irrespective of the strength of the concrete. The precise shape of the curve is very dependent on the length of time the load is applied (Bungey *et al.*, 1995).

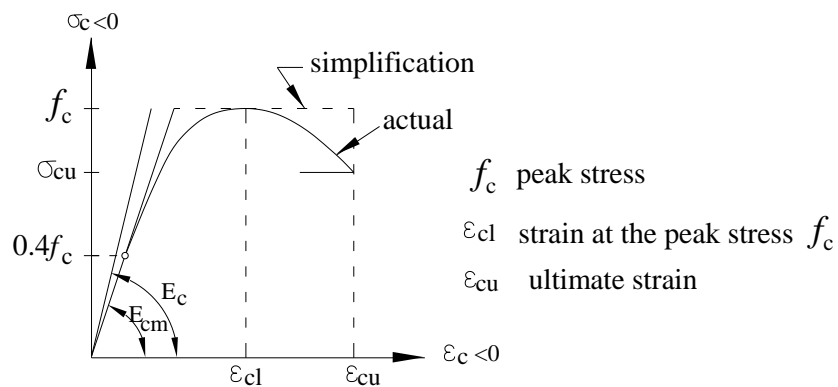

Figure 2.6: Typical stress-strain relationship for concrete.

In the figure,  $\epsilon_{cl} = 0.0022$ ;  $\epsilon_{cu} = 0.0035$ ;  $E_{cm}$  = mean value of the secant modulus.

Source: (Mosley *et al.*, 1996)

**(f) Modulus of Elasticity**

The modulus of elasticity depends on the strength class of concrete, properties of aggregates used and the mean value of the secant modulus  $E_{cm}$  for a particular class is shown in Table 2.7, as obtained from Table 3.2 of Euro code 2.

Table 2.7: Values of the secant modulus of elasticity  $E_{cm}$  (in kN/mm<sup>2</sup>)

Strength class,	C12/15	C16/20	C20/25	C25/30	C30/37	C35/45	C40/50	C45/55
$E_{cm}$	26	27.5	29	30.5	32	33.5	35	36

Source: (Table 3.2, Euro code 2)

The values in Table 2.7 above are based on Equation (2.9), where  $E_{cm}$  is in kN/mm<sup>2</sup> and  $f_{ck}$  is in N/mm<sup>2</sup>,  $f_{ck}$  is strength at 28 days.

$$E_{cm} = 9.5[f_{ck} + 8]^{1/3} \quad (2.9)$$

The modulus of elasticity is required when investigating deflection of a structure, when investigating cracking of a structure and when considering both short term and long term effects of creep and shrinkage (El-Reedy, 2009).

**(g) Durability**

Durability is usually considered in terms of the proposed life of the structure and its conditions of exposure. This is the resistance to wear, tear and environmental effects with time. Any reinforced concrete structure must be designed to protect the embedded steel. Thus the durability of concrete is influenced by exposure conditions, concrete quality and workmanship, cover to reinforcement and width of any crack. If durability is neglected, it will lead to increased expenditures on inspection, maintenance and repair. Durability of reinforced concrete concerns the selection of the appropriate

concrete grade and cover, for the conditions of environmental exposure and protection of reinforcement against a rapid rise in temperature and resultant loss of strength (Chanakya, 2009).

### **2.2.5 Waste Ceramic and Porcelain Clay Tile Powder**

Ceramics are inorganic and non-metallic solids which can be highly crystalline, semi crystalline, vitrified or completely amorphous. The most commonly used ceramics are brick, glass and porcelain. Ceramics are grouped into two main groups which include the crystalline ceramics and the non-crystalline ceramics. The crystalline ceramics are found to be non-submissive to the wide range of processing and hence the crystalline ceramic is prepared in a desired shape either by forming powders in the desired shape and then heating it until it becomes a solid mass or by reaction on site.

On the other hand, non-crystalline ceramics are made from melts and in this process, the shape of the glass is formed either when it is in a toffee like viscosity or on a molten state. Ceramic waste is available in large quantities especially from large ceramic factories, ceramic product manufacturing units and also from everyday construction activities. Traditional ceramics which include bricks, roof and floor tiles, other construction materials, and technical ceramics like porcelain possess wide compositional range of the natural clays used as raw materials and this makes them highly heterogeneous (Sivaprakash *et al.*, 2016).

There are two most common tiles available in Uganda; ceramic and porcelain tiles. The differences between ceramic and porcelain tile lies in the fact that both are made



with clay, but ceramic tiles also have sand mixed in. Porcelain tiles are usually made using denser clay than that used in ceramics. The vast majority of tiles sold in Uganda are made with either ceramic or porcelain. Figure 2.7 shows a sample of ceramic tile waste at one of the demolition site in Bukoto. Ceramic wastes are categorized into two groups in accordance with the source of raw materials. The first one are all fired wastes generated by the structural ceramic factories that use only red pastes to manufacture their products, such as brick, blocks and roof tiles. The second one is all fired waste produced in stoneware ceramic such as wall, floor tiles and sanitary ware. According to Pacheco *et al.*, 2010 ceramic waste may be classified by type and production process. Ceramic wastes were classified into white paste and red paste, in each case further categorized as either once-fired or twice-fired.



Figure 2.7: Ceramic tile waste at demolition site.

Porcelain ceramic tile is a highly vitrified ceramic material produced from a body formulated by mixtures of kaolin, quartz and feldspar. The kaolin [ $\text{Al}_2\text{Si}_2\text{O}_5(\text{OH})_4$ ], gives plasticity to the ceramic mixture; flint or quartz ( $\text{SiO}_2$ ), maintains the shape of the formed article during sintering; and feldspar [ $(\text{K}, \text{Na})_2\text{O} \cdot \text{Al}_2\text{O}_3 \cdot 6\text{H}_2\text{O}$ ], serves as flux. These three constituents place porcelain in the phase system [(K, Na) $_2$ O-Al $_2$ O $_3$ -SiO $_2$ ] in terms of oxide constituents, hence the term triaxial porcelain ceramic tiles (Buchanan, 1991; Olupot, 2006). The main phase composition of a porcelain body is

characterized by a heterogeneous glassy matrix composition and needle shaped mullite crystals interlocking together with some quartz grains and closed irregular shaped pores. The crystals of mullite are endowed together with excellent mechanical, thermal and chemical properties. Processing routes and the kinetics of the firing process, porcelains represent some of the most complicated ceramic systems reason being the complex interplay between raw materials (Lopez, 2011).

### **2.2.6 Environmental Impact Assessment**

Environmental Impact Assessment (EIA) is defined as a tool for ensuring new projects and programmes incorporate appropriate measures to mitigate adverse impacts to the environment and health and safety of people as well as enhancement of sustainable operations with respect to environmental resources including co-existence with other socio-economic activities in their neighbourhood (Kenface, 2016). It is a procedure used to examine the environmental consequences (both beneficial and adverse) of a proposed development project and to ensure that these effects are taken into account during the project design phase. For this reason, the EIA is therefore usually based on predictions. These impacts assessed can range from all relevant aspects of the natural, social, economic and human environment (Ogola, 2009).

EIA certainly has a crucial role to play in addressing environmental issues surrounding project development and therefore the integration of environment into development planning forms one of the most important tools in achieving sustainable development. In addition, environmental protection and economic development must thus be dealt with in an integrated manner. EIA process is necessary in providing an anticipatory

and preventive mechanism for environmental management and protection in any development (GIBB, 2014). EIA is therefore viewed as an integral part of the project planning phase. Unlike the environmental audit (EA), which is usually conducted on existing projects, the EIA is applied to new projects and the expansion aspects of existing projects. The study therefore requires a multidisciplinary approach and should be done very early at the feasibility stage of a project. In other words, a project should be assessed for its environmental feasibility (Kenface, 2016).

Social Impact Assessment (SIA) includes the processes of analysing, monitoring and managing the intended and unintended social consequences, both positive and negative, of planned interventions and any social change processes invoked by those interventions. The analysis includes the use of land, culture, the main economic activities e.g. tourism, employment levels, agriculture and impact on service provision e.g. water use, education, traffic, energy use among others. Its primary purpose is to bring about a more sustainable and equitable biophysical and human environment. SIA assumes that social, economic and biophysical impacts are interconnected. It is therefore done to ensure that there is no mismatch between the development and socio-cultural aspects of the project area (Ogola, 2009). The purposes of the environmental impact assessment are to: propose workable mitigation measures; ensure adequate identification of potential environmental impacts; develop an environmental management and monitoring plan articulating envisaged impacts; and formulate implementation framework for the proposed mitigation measures, required resources, responsible persons and implementation schedule.

On the other hand, the objectives of this assessment are to: determine and assess the impacts of the proposed project and to develop appropriate mitigation measures; ensure there is compliance with the provisions of the National Environmental Management Authority (NEMA) as well as other statutory requirements; prepare an Environmental Management Plan (EMP) which can be used as the basis for future audits; and ensure that the proposed project does not compromise the well-being of the people including all other stakeholders.

## **2.3 Empirical Review**

### **2.3.1 Engineering Properties of Waste Material Used as Partial Replacement of Cement in Concrete**

Ceramics are brittle solids and are suitable for withstanding very high temperatures. They are inert which is responsible for their ability to confront the damages caused by oxygen, acids, or any other chemicals. The ceramics are also considered to be anti-static in that they prevent the build-up of static energy that is responsible for the imbalances caused by friction. In addition, the ceramic materials are also high resistant to both electricity and heat which makes them very durable. They also have high fracture toughness and have similar modulus to that of steel. Based on experimental research, water absorption of ceramic waste is established to be 0.18% and that for natural aggregate is 0.10% (Guerra *et al.*, 2008).

An investigative study on the mechanical properties of porcelain conducted by Braganca *et al.* (2004) reported the optimum sintering temperature for the porcelain studied was 1340°C using a heating rate of 15°C/h and a 30 min soaking time. The

modulus of rupture and bulk density were at a maximum at this temperature. The study findings give the following properties of porcelain: water absorption is 0.34%, apparent porosity is 0.84%, bulk density is 2.48 g/cm<sup>3</sup>, linear shrinkage is 12.2% and modulus of rupture is 46 MPa. Technical data analysis revealed a relationship between the modulus of rupture and the bulk density adding that maximum strength is achieved as a result of decrease in internal flaws and porosity. The study found that samples fired at temperatures below the ideal (1340°C) showed open porosity.

Stathis (2004) asserts that filler grain size has severe impact on the mechanical and physical properties of porcelain compared to the impact of the other factors such as firing temperature, quartz content in the filler and soaking time. This therefore suggested that, optimization efforts should be focused on this factor. The study showed that bending strength is affected by quartz grain size in two ways, indirectly through the development of a favourable microstructure, and directly through the induction of compressive stresses to the vitreous phase. It is explained that the particle distribution of quartz grains is major factor upon which both parameters depend. The study found that the maximum bending strength was achieved with the optimum quartz grain size of 5–20 µm. It was noticed that the use of coarser grain sizes results in reduced bending strength due to the development of a detrimental microstructure.

According to Pacheco *et al.* (2010), the chemical compositions of ceramic waste and porcelain tile powder has been established to vary greatly based on the type of ceramic tile. The main chemical component is SiO<sub>2</sub> which is found in the largest proportion followed by Al<sub>2</sub>O<sub>3</sub>. Other minor chemical constituents include Fe<sub>2</sub>O<sub>3</sub>, CaO, MgO,

Na<sub>2</sub>O, and K<sub>2</sub>O while TiO<sub>2</sub> is the least found chemical constituent. The chemical composition of the ceramic waste also tends to influence the specific gravity of the ceramic waste as established by Siddesha (2011) who conducted a study using homogeneous ceramic tiles.

On the microstructural analysis Braganca *et al.* (2004) revealed that the ideal firing temperature occurs when the glassy phase covers the entire sample surface with sufficient time to react with crystalline phases. Higher temperatures were limited by the porosity increase. This porosity is a result of oxygen released from Fe<sub>2</sub>O<sub>3</sub> decomposition and gas expansion in the pores. Finally, the mechanical and physical properties of concretes in which conventional coarse aggregate was partially substituted by coarse ceramic aggregate obtained from crushed sanitary porcelain ware was studied by López *et al.* (2007) and Juan *et al.* (2010) studied. The study reported good results.

### **2.3.2 Performance of Structural Concrete Mix with Waste Material used as Partial Replacement**

The basic concept of a mix design is to select and proportion suitable materials so as to provide a required strength and workability. Strength is normally assumed to be inversely proportional to water cement ratio and workability to slump and cohesion or sandiness. The more sand and the higher the water requirement (and therefore the cement requirement and cost) but the 'softer', more cohesive and easier to handle the concrete at a given slump. To a large extent, using a finer sand has the same effect as using a larger percentage of sand (Ken, 2006). The concrete which is mixed with

ceramic waste powder has a minor strength loss but possesses increased durability performance because of its pozzolanic properties. Replacement of conventional coarse aggregates by ceramic coarse aggregates produces concrete with promising results but they slightly underperform in water absorption (Pacheco, 2010).

Pacheco *et al.* (2010) conducted a study on the behaviour of concrete with partial replacement of tile powder in cement accordingly in the range of 0 to 50% in steps of 10% by weight for class C30 concrete. The tile concrete samples were tested and comparison made with the conventional concrete. The compressive strength, tensile strength and flexural strength for 7, 28 and 56 days for the various replacement levels were compared. The materials used were; ordinary Portland cement of 53 grade cement conforming to IS 8112:1989 of initial and final setting time of 55 minutes and 210 minutes respectively and also of specific gravity 3.15. Tile dust of fineness 7.5% and specific gravity of 2.62 was obtained from RAK ceramics. Local river sand conforming to zone-II of IS 383-1970 with fineness modulus is 3.69, specific gravity of 2.64, bulk density  $1718 \text{ kg/m}^3$  and water absorption 0.4% was used as fine aggregate while locally crushed granite stone of maximum size 20mm, fineness modulus of 7.357, specific gravity 2.67, bulk density  $1605 \text{ kg/m}^3$  and water absorption 3.72% was used as coarse aggregate. The quantity and quality of water was very carefully determined. Super plasticizer used was conplast SP430 with brown liquid appearance, specific gravity 1.18 and alkali content less than 55g. Concrete mix of strength class C30 was designed as per IS 10262: 2009 and the variation of strength of hardened concrete using tile dust as partial cement substitute was studied by casting 3 cubes, 3 cylinders and 3 beams for each replacement level. The specimens were cured for 7, 28

and 56 days prior to being tested for compression, split tensile and flexural strengths. The results of the study showed that compressive strength, split-tensile strength and flexural strengths were achieved up to 30% partial replacement level without affecting the characteristic strength of C30 grade concrete. Beyond 30% replacement level, the strengths gradually decreased when compared to the conventional (control) concrete.

Sivaprakasha *et al.* (2016) experimentally studied the mechanical strength properties of C25 grade concrete by partially replacing sand with ceramic waste. In order to analyse the mechanical properties such as compressive, split tensile, flexural strength, the samples were cast with 10–50% in steps of 10% replacement of sand using ceramic waste. The tests were carried out after 7, 14 and 28 days of curing. The test results showed clearly that the ceramic waste can be used as replacement materials for river sand in concrete. The concrete with 10 and 20% replacement satisfied the compressive strength of M25 grade however higher the percentage addition of ceramic waste reduces the strength of normal concrete. The tensile strength of 10, 20, 30% replacements at 14 days showed the consistency in attaining the required range. Hence it was concluded in this study that the replacement of river sand using 30% ceramic waste in concrete gives the required strength and can be considered as optimum replacement level. It was observed that the mechanical properties of concrete reduced with further increase in the percentage addition of ceramic waste.

The reuse of ceramic tiles waste (CWT) as aggregate in concrete was studied by Shruti *et al.*, 2016. In their study, natural coarse aggregates were partially replaced with ceramic tile waste. The replacement levels were 0, 10, 20, and 30% substitution of C20



grade concrete. The concrete cubes and cylinders were cast and tested for compressive strength and split tensile strength respectively after curing periods of 3, 7 and 28 days for each replacement level. The result indicate that the maximum compressive strength is obtained for 30% replacement of ceramic tile aggregate with natural coarse aggregate.

The effect of replacing crushed clay tiles as a coarse aggregate in concrete with partial replacement of 0, 50, and 100% of natural aggregate was experimentally investigated by Topcu *et al.* (2007). In this study, both physical and mechanical tests were carried out. The results revealed that the unit weights and strengths of crushed tile aggregate concrete decreased with increase in waste material, compared to control concrete. On the contrary, water absorption and capillary coefficients were increased compared to the control concrete. In the light of the same, Ikponmwosa *et al.* (2017) also studied the effect of ceramic waste as coarse aggregate substitute on particularly the strength properties of concrete. The study concluded that ceramic waste could be used for both non-structural and structural works while recommending that beyond 75% substitution level, ceramic waste material should not be used in concrete structures where high strength is the major consideration. In addition, Reddy *et al.* (2007) concluded that ceramic scrap can be partially used to replace conventional coarse aggregates up to 10 and 20% replacement levels without structurally affecting its performance and hence significance.

Hemanth *et al.* (2015) studied the effect of waste ceramic tiles as partial replacement of both fine and coarse aggregates in concrete production. In this study crushed

ceramic waste tiles were used to partially replace the fine and coarse aggregate (10 and 20%). The results showed that the optimum percentage of coarse aggregate that can be replaced by crushed tiles is 10%. In addition, Senthamarai *et al.* (2005) studied the possibility of using wastes from the ceramic industry as coarse aggregate in structural concretes, and obtained satisfactory results. Not only these studied but also Gomes *et al.* (2009) investigated the feasibility of incorporating ceramic block waste as coarse aggregates in the production of new concretes and concluded that in terms of durability these new concretes incorporating recycled aggregate could be used for structural purposes, but that the 4-32 mm fraction of natural aggregates could not be substituted in its entirety. Furthermore, Cachim (2008) used different kinds of crushed waste ceramic blocks as partial substitute (15, 20 and 30%) of coarse natural aggregates, observing that with 15% substitution there was no change in concrete strength.

On the other hand, the feasibility of using red ceramic waste as a partial and total substitute for natural fine aggregates was analysed by Silva *et al.* (2010). In this study substitution percentages of 20 and 50% results were at all times superior to those for the reference mortar. However, the behaviour was poorer than that of the reference concrete when natural fine aggregate was totally substituted. Additionally, Binici (2007) also used crushed ceramic waste and pumice stone as a partial substitute for fine aggregate in the production of mortars and concretes, concluding that these presented good compressive strength and abrasion resistance. Other studies also include Saswat *et al.* (2016) who investigated the possibility of partial replacement of fine aggregate with a combination of ceramic and demolition waste from rigid pavements. The study concluded that 40% of natural fine aggregate can be saved while

making rigid pavement by using ceramic and demolition waste. In addition, it was established that the compressive strength is more than that of referral concrete up to 20% demolition waste and 20% ceramic waste.

Experimental studies have found that with the use of ceramic waste powder in cement concrete, 30% ceramic waste powder can substitute fine aggregate in cement concrete without loss of compressive strength Hardil *et al.* (2015). The study also concluded that compared to conventional concrete, only about 1% loss of split tensile strength is obtained. Not only the above but Vidivelli *et al.* (2010) also studied on fly ash concrete using SEM analysis as partial replacement to cement and had reported a significant increase of 20% compressive strength.

Furthermore, Koyuncu *et al.* (2004), Topcu (2007), Brito (2010), Correia *et al.* (2006), and Bakri (2006) agree on the viability of using recycled ceramic aggregate in non-structural concretes, which show good abrasion resistance and tensile strength properties, and because of the increased durability of recycled concrete, they are suitable for use as paving slabs. Puertas *et al.*, (2008) studied 6 types of ceramic wastes, using them as alternative materials in the production of raw cement; the study established the feasibility of this use while demonstrating a level of pozzolanic activity together with suitable chemical and mineralogical composition.

The performance of fly ash as partial replacement of cement was studied by Kumar *et al.* (2012). Both compressive strength and split tensile strength were determined at various partial replacement levels of cement (0, 10, 20, 30 and 40%) by weight of C5

and C40 mixes. The compressive strength of the samples was determined at the curing age of 7, 14, 28 days whereas the splitting tensile strength of the test specimens were conducted at the age of 56 days. In this study, it was observed that the best value of compressive strength was achieved at 14 days.

Amudhavalli *et al.* (2012) examined the performance of concrete incorporating silica fume as the partial cement substitute. Cement was replaced with silica fume in steps of 0, 5, 10, 15 and 20% by weight by M35 mix. The study reported compressive strength, split tensile strength and flexural strength at age of 7 days and 28 days for several replacement levels. The results indicated that the performance of concrete in strength and durability aspects improves by incorporating silica fume in concrete. Raval *et al.* (2013) explained the feasibility of replacing cement with ceramic waste and utilizing the same in construction industry. The study revealed that compressive strength was achieved up to 15% replacement level. In addition, the use of glass powder as partial replacement to cement was effective (Vijayakumar *et al.*, 2013).

The compressive strength of concrete in which cement was partially substituted with silica fume (0, 5, 10, 15, and 20%) was determined by Pradhan *et al.* (2013). The compressive strength tests were conducted on specimen (100 mm and 150 mm cubes) at 1, 7 and 28 days of curing. The results presented that with addition of silica fume up to 20% replaced by weight of cement, the compressive strength of concrete increased. Upon further addition of silica fume, the compressive strength may increase or decrease.

Ajileye *et al.* (2012) examined the partial replacement of cement with usage of microsilica in concrete. Cement was replaced with coconut shell in the range of 0-25% in steps of 5. The compressive strength and of the samples was recorded at the curing age of 3, 7, 14, 28 days. The results showed that with addition of silica fume up to 10% replaced by weight of cement, the compressive strength of concrete increased. However, with further addition of microsilica the compressive strength decreased.

Utilization of natural pozzolanic cement substitute in concrete materials has been determined by Al-Chaar *et al.* (2013). In this study, four mixes using three types of natural pozzolanic, as well as a Class F fly ash were investigated by means of a test series. The effectiveness and efficiency of each pozzolanic material in controlling alkali-silica reactions was established. The study also revealed correlations between Portland cement control mix and the mechanical properties of the proposed mixes. The findings were also compared with the industry standards for mortars made with silica fume and fly ash. These findings to indicate that one type of pozzolanic may be used as a substitute for fly ash, but not for silica fume.

### **2.3.3 Cost-Benefit of using Waste Material as Partial Replacement of Cement**

For the economic analysis, a cost-benefit analysis technique may be used to perform validity analysis on an investment and was applied for a cost comparison of facility construction. The two are identical in that both consider the temporal value of cost. The main difference is that cost-benefit analysis explicitly handles both cost and benefit, while economic analysis has to do with only cost. Barrie *et al.*, (2002) suggested three types of estimates (preliminary estimates, fair-cost estimates, and

definite estimates) for the efficient management of construction costs. Depending on accuracy. pre-cost and post-cost according to quotation time, Kim *et al.*, (2004) classified estimates into definite and preliminary estimates. In this classification, the cost estimated before construction is completed is defined as pre-cost and it is further sub-classified into preliminary, design, construction and budget cost of work schedule (BCWS) estimates. On the other hand, the actual consumption (so-called “actual cost”) is referred to as post-cost estimate and it represents basic data used for the preparation of construction financial statements.

Studies which minimize cement usage, develop alternatives for instance by partial replacement of cement with fly ash, blast-furnace slag, or such industrial by-products and assess the environmental impacts and economic value of concrete mixed with such have become of prime interest to the construction industry. In a study conducted by Tae (2016), a physical property evaluation of concrete was investigated by using A-BFS (Activator Blast Furnace Slag) mixed with an activator in order to induce early-age strength manifestation of BFS mixed concrete. This study primarily conducted physical property tests for compressive strength of concrete that partially replaced ordinary Portland cement with A-BFS and executed a comparative analysis with 100% ordinary Portland cement. According to which the economic value of the construction period, reduction was evaluated based on the fact that if concrete early strength is manifested through this process when applied to RC (reinforced concrete) building, at most a three to four-day construction cycle would be possible.

The combination of waste sheet glass powder (SGP) as substitutes for both fine aggregate and Portland cement with 20% optimum substitution of fly ash as cementations binder was found to offer an economically viable technology for high value utilization of industrial waste. Use of SGP in concrete is also an interesting possibility for conservation of natural resources as well as economy on waste disposal sites. In this study, natural sand was partially replaced with SGP in steps of 10% in the range of 0-50%. A 20% optimum replacement of Portland cement with fly ash was also made. Compressive, tensile and flexural strengths up to 180 days of age were compared with those of the conventional concrete made with natural fine aggregates. The study results indicate that the manufacture of low cost concrete containing SGP produces similar characteristics to those of natural sand aggregate concrete up to 30% SGP as fine aggregate along with 20% optimum cement replacement with fly ash (Mageswari *et al.*, 2009).

In order to minimize the environmental damages due to quarrying, Biruk *et al.* (2012) developed the strength of concrete by using masonry waste in concrete mix for construction purposes. The study noted that it is highly desirable that the waste materials of bricks and concrete are further reutilized after the demolition of old structures in an effective manner especially realizing that it will minimize damages to the environment caused by excessively reckless quarrying for earth materials such as stones. In addition, the pressure of finding new dumping ground for these wastes will reduce when they are reutilized, thus further saving the eco-systems and natural environment at large. The reliability, durability and adequacy in service performance of these reused waste materials over the stipulated design period of structures are of

paramount concern. In this study, such properties of reused concrete and brick masonry waste materials were critically examined and suitable recommendations suggested for further enhancing life of such structures, thereby resulting in sufficient and sustainable economic growth and development.

#### **2.4 Literature Review Summary and Research Gaps**

Though studies have been conducted trying to investigate how ceramics may be used as partial replacement in concrete, the studies have focused entirely on using either ceramic or porcelain waste directly (Bragança *et al.*, 2004; Meena, 2017; Olupot, 2006) leaving out the use of both wastes simultaneously. Most studies indicate the feasibility of using either or both ceramic and porcelain waste as partial replacement for coarse aggregates (Pacheco *et al.*, 2010; Sivaprakash *et al.*, 2016; Sentharamai *et al.*, 2005; Siddesha, 2011; Sudarsana *et al.*, 2013; Pacheco *et al.*, 2010; Topcu *et al.*, 2007; Ikponmwosa *et al.*, 2017; Hemanth *et al.*, 2015; Senthamarai *et al.*, 2005; Gomes *et al.*, 2009; Cachim 2008). Furthermore, Koyuncu *et al.* (2004), Topcu (2007), Brito *et al.* (2010), Correia *et al.* (2006), and Bakri (2006) agree on the viability of using recycled ceramic in non-structural concrete to replace aggregates and not cement. In addition, studies have been conducted to analyse the feasibility of using red ceramic waste as a partial and total substitute for natural fine aggregates (Sivaprakasha *et al.*, 2016; Silva *et al.*, 2010; Binici, 2007; Saswat *et al.*, 2016).

On the other hand, several waste materials such as stone dust, oven burnt bricks, glass powder, coconut shells, waste tires, slag, fly ash, broken glass pieces, rice husk ash, coconut shell ash have been used in concrete to partially replace cement. These studies



(Puertas *et al.*, 2008; Portella *et al.*, 2006; Hardil *et al.*, 2015; Vidivelli *et al.*, 2010; Vijayakumar *et al.*, 2013; Kumar *et al.*, 2012; Pradhan *et al.*, 2013; Amudhavalli *et al.*, 2012; Al-Chaar *et al.*, 2013; Ajileye *et al.*, 2012; Ghutke1 *et al.*, 2014) established the feasibility of using particular waste material as partial replacement of cement in concrete production. In addition, today the Portland cement manufacturing industry is under close scrutiny reason being the large volumes of CO<sub>2</sub> emitted. Actually about 5–7% of the total CO<sub>2</sub> anthropogenic emissions is thought to be produced by this industrial sector (Hendricks *et al.*, 1998; Humphreys *et al.*, 2002). Therefore, numerous studies have been done to evaluate and possibly reduce CO<sub>2</sub> emissions and energy consumption (Capros *et al.*, 2001; CIF, 2003; Gartner, 2004). Other cement emissions such as SO<sub>2</sub> emissions have also been analysed (Josa *et al.*, 2004, 2007) using Life Cycle Assessment (LCA) method. Other studies (Tae, 2016; Gamashta *et al.*, 2006; Mageswari *et al.*, 2009; Hailu *et al.*, 2012) have also been conducted to evaluate the cost of structures using alternative ingredients of concrete.

In a nutshell, studies have focused entirely on using either ceramic or porcelain waste directly leaving out the use of both wastes simultaneously. Most studies indicate the feasibility of using either or both ceramic and porcelain waste as partial replacement for aggregates. No conclusion has been made on the cost benefit assessment of using both ceramic and porcelain waste as partial cement substitute in concrete production. The impacts of using ceramic and porcelain waste on the environment in terms of cost and benefits have also not been established. This study therefore aimed at addressing these research gaps.

## 2.5 Conceptual Framework

The structure for the study based on literature is illustrated diagrammatically (showing relationship between variables) in the conceptual frame shown in Figure 2.8.

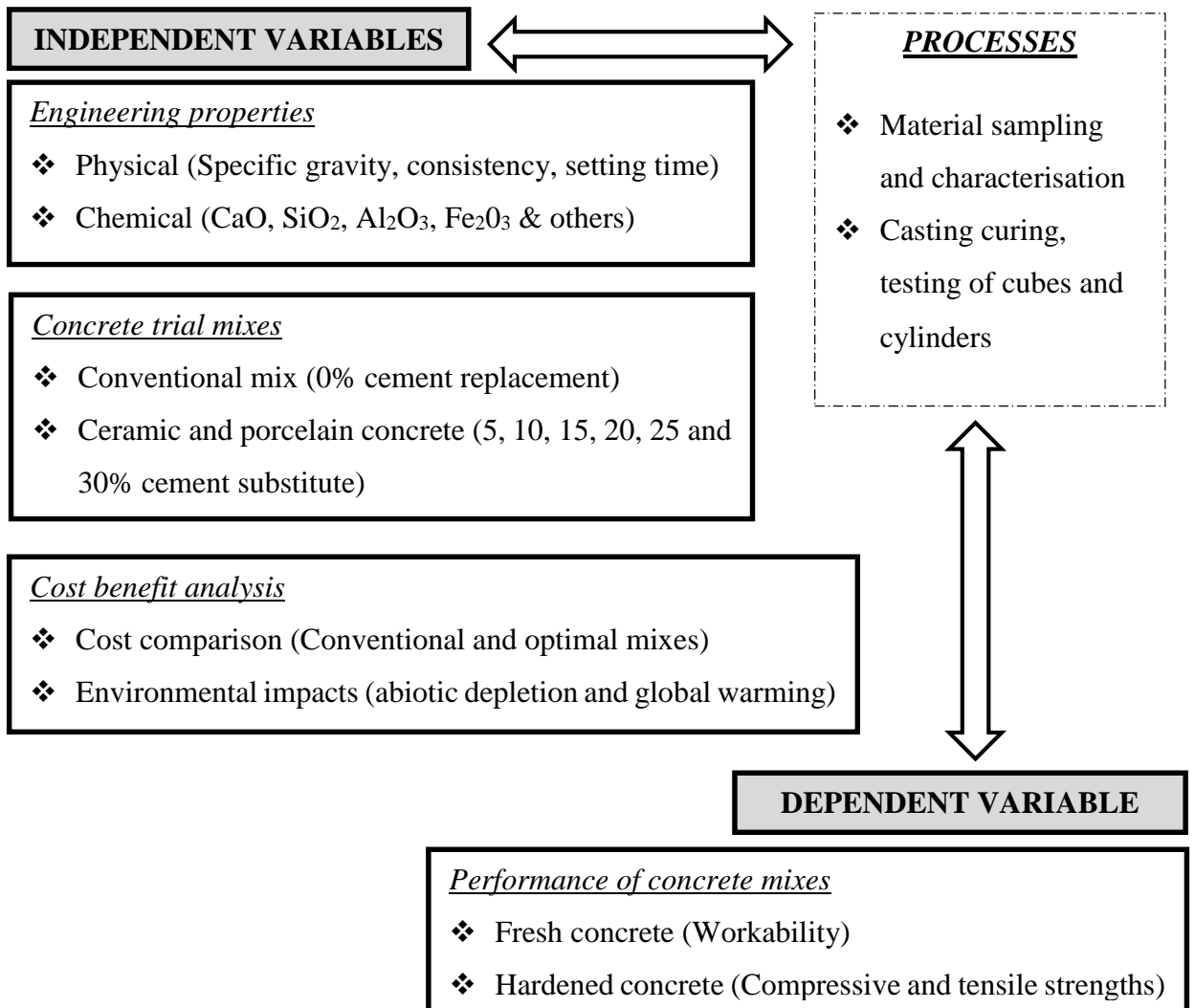

Figure 2.8: Conceptual framework.

## **CHAPTER THREE**

### **MATERIALS AND METHODS**

#### **3.1 Introduction**

This chapter represents the methodology that was used in achieving the study objectives. According to Kothari (2004), the methodology emphasizes the procedure and details on how this research was carried out, and this is elaborated herein. It constitutes the methods used, the material sampling and preparation, the data collection, processing and analysis procedures. It contains the experimental setup regarding what, where, when, how much, by what means the inquiry was carried out.

#### **3.2 Determining Engineering Properties of Ceramic and Porcelain Clay Tile Powders**

##### **3.2.1 Material Acquisition and Preparation**

Ceramic and Porcelain clay tile waste was sampled from Kampala and its environs, targeting construction sites, areas of Kireka sites that sell tiles, Namave where many tile producers are available, Bukoto as an area of major demolition and Namugongo area undergoing a lot of construction. Samples of ceramic and porcelain clay tiles was taken in accordance to BS 1881-101: 1983, which gives methods of sampling. In February 2018, 50 kg of each waste material (ceramic and porcelain clay tiles) was taken from each of the 20 demolition sites within Kampala metropolitan area. The samples were packed in polypropylene semi-transparent woven plastic sack bags and transported to the crushing plant using Sinotruk HOWO 8X4 Dumper 420HP Dump Truck. The sample was washed and left to air dry for one week before it was crushed

into powder using the MRBJC semi-automatic stone crushing plant in Muyenga, a suburb in Kampala. The waste powders were then packed into kraft paper laminated HDPE woven bags and transported to the Teclab laboratory in Ndeeba, Kampala. The latitudes and longitudes of the study sites are presented in Table 3.1.

Table 3.1: Geographical coordinates of study sites

Location	Coordinates (° ' ")		Activity
	Latitude	Longitude	
Kireka	0°20'48.0" N	32°39'00.0" E	Demolition sites
Bukoto	0°21'04.0" N	32°35'47.0" E	Demolition sites
Namave	0°21'27.0" N	32°41'39.0" E	Construction sites
Namugongo	0°23'43.0" N	32°39'57.0" E	Construction sites
Muyenga	0°17'38.0" N	32°36'41.0" E	Crushing plant
Bweyogerere	0°21'09.0" N	32°39'49.0" E	UNBS Laboratory
Ndeeba	0°17'24.0" N	32°33'54.0" E	Laboratory works
Nairobi	1°16'60.0" S	36°49'0.01" E	Chemical tests

Figure 3.1 presents the geographical location of the study area. This map was extracted from the Kampala Capital City Authority (KCCA) Strategic Plan 2014/15-2018/19.



Figure 3.1: Location of study area.

### 3.2.2 Data Collection Procedure

The physical and chemical properties of the powders were determined in accordance to the American Standard of Testing Materials (ASTM) and British Standard (BS). X-Ray Fluorescence Spectrometer method was employed in the determination of the chemical compositions of the powders. The physical properties were conducted from Uganda National Bureau of Standards (UNBS) laboratory in Bweyogerere while the chemical composition was determined from the state department of mining, ministry of petroleum and mining in Nairobi. The test method used to establish these properties are given in Table 3.2.

Table 3.2: Test methods for establishing properties of ceramic and porcelain powders

Property	Test Method
Specific Gravity	ASTM C 188
Consistency	ASTM C 187
Setting Time	BS EN 196-3:2016
Chemical Composition	X-Ray Fluorescence Spectrometer

From the test results, conclusions were made to justify whether crushed ceramic and porcelain clay tiles possess adequate pozzolanic properties to warrant its use as partial cement substitute in concrete production. The schematic diagram for determining the engineering properties of ceramic and porcelain powders is shown in Figure 3.2.

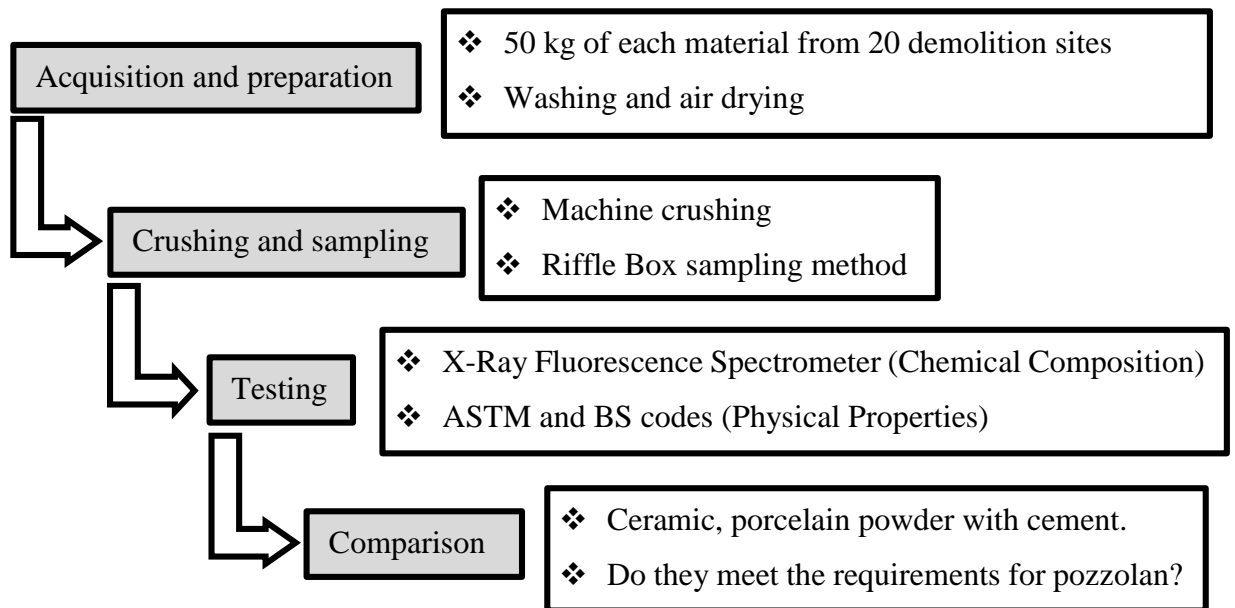

Figure 3.2: Schematic diagram for determining engineering properties of ceramic and porcelain clay tile powders.

Le-Chatelier apparatus (Figure 3.3) was used to determine the specific gravity of both ceramic and porcelain clay tile powders.

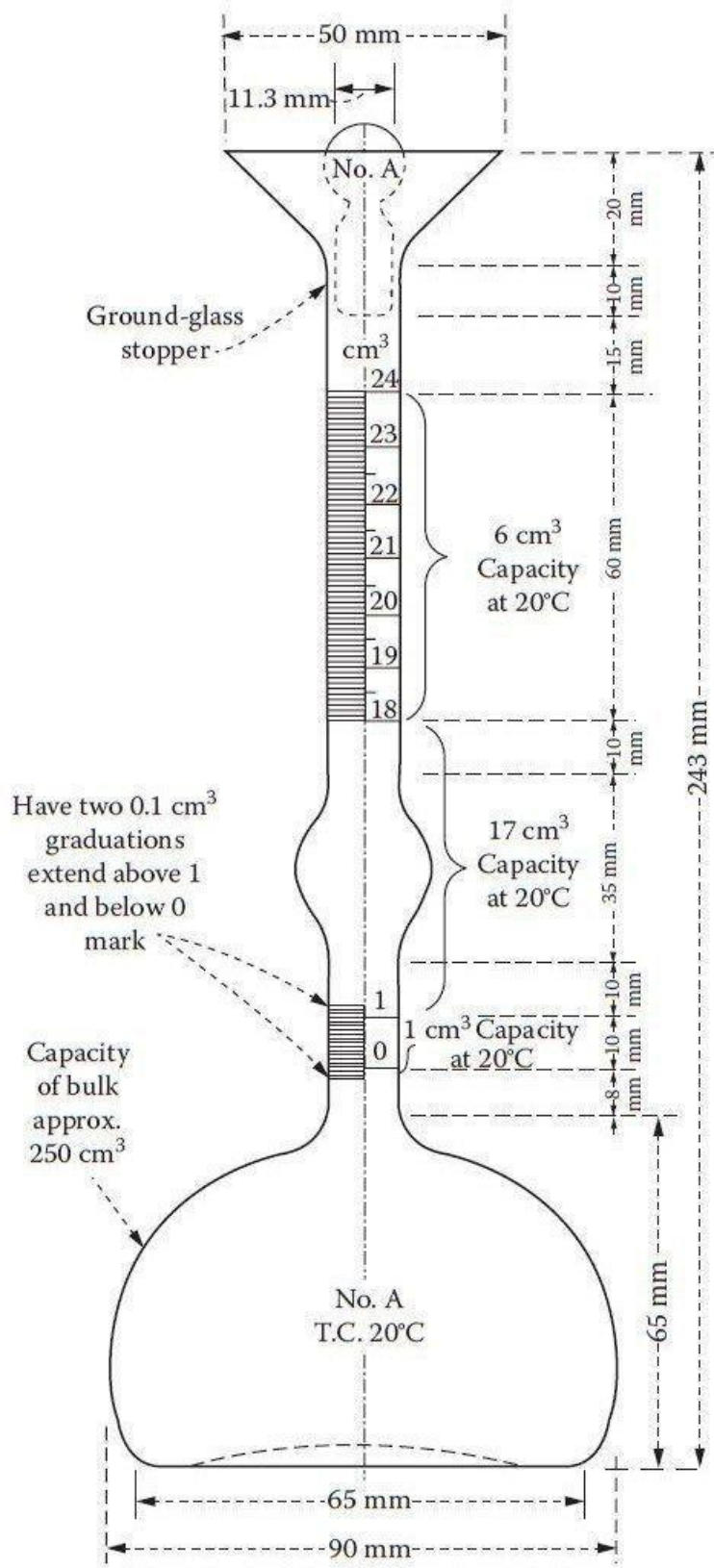

Figure 3.3: Le-Chatelier flask for determining specific gravity



The normal consistency and setting time of both ceramic and porcelain clay tile powders were determined using the Vicat apparatus shown in Figure 3.4.

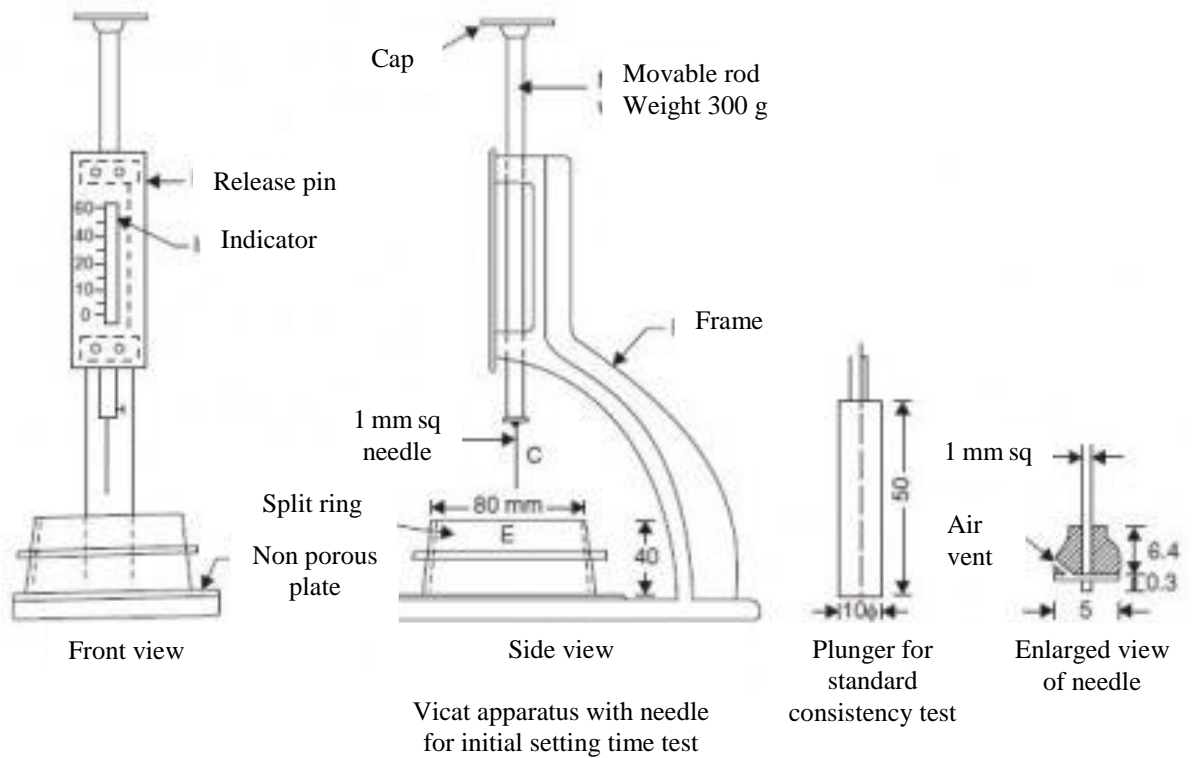

Figure 3.4: Vicat apparatus for determining consistency and setting time of binder

The chemical composition of ceramic and porcelain clay tile powders was determined using the X-Ray fluorescence spectrometer (Figure 3.5). The provision of ASTM C 618 was used to assess the feasibility of used ceramic and porcelain powders as possible cement substitutes. In other words, combined percentage of silica ( $\text{SiO}_2$ ), iron oxide ( $\text{Fe}_2\text{O}_3$ ), and alumina ( $\text{Al}_2\text{O}_3$ ) for both ceramic and porcelain clay tile powders was checked if it met the 70% minimum requirement for a good pozzolan.



Figure 3.5: X-Ray Fluorescence Spectrometer

### 3.2.3 Data Analysis

The methods of processing and analysing laboratory results was done in accordance to the appropriate standards listed in Table 3.1. Conclusions were drawn on the feasibility of using crushed ceramic and porcelain clay tile powder as possible cement substitute in concrete production by comparing its properties against those of standard ordinary Portland cement (OPC). According to ASTM C 125, a pozzolan is defined as a siliceous and aluminous material which, in itself, possesses little or no cementitious value but which will, in finely divided form in the presence of moisture, react chemically with calcium hydroxide at ordinary temperature to form compounds possessing cementitious properties. Portland cement must have a number of qualities to be acceptable. It must contribute to workability of the concrete or mortar; must set and get hard in a specific time; must have good finishing characteristics; must produce a concrete or mortar that will serve without deterioration; must adhere to the aggregate particles and to the reinforcement; and must be compatible with admixtures.

### **3.3 Evaluating the Performance of Concrete with Ceramic and Porcelain Clay Tile Powders as Partial Cement Substitutes**

#### **3.3.1 Material Acquisition and Preparation**

##### **(a) Cement**

Cement may be prescribed as material with both cohesive and adhesive properties which allow it to bond with fragments of material into a completely compact whole. Today, Portland cement is the most commonly used cement in construction and, hence, in this study ordinary Portland cement of 42.5 grade was selected for the investigation. It was dry, powdery and free of lumps. The cement according to the specification satisfied the BS EN 197-1:2000. The specifications (physical properties and chemical composition) of ordinary Portland cement used in this study are shown in Tables 3.3 and 3.4 respectively. On 14<sup>th</sup> March 2018, 10 bags of this brand of cement were purchased from Seroma Hardware in Kampala and transported to Teclab laboratory in Ndeeba.

Table 3.3: Physical properties of ordinary Portland cement

Property	BS EN 197-1:2000
Specific gravity	3.15
Consistency (%)	30
Initial setting time (minutes)	60 minimum
Final setting time (minutes)	540 minimum

Table 3.4: Chemical composition of ordinary Portland cement (OPC)

Component	Tororo OPC (% by mass)
SiO <sub>2</sub>	18.24
CaO	60.82
Al <sub>2</sub> O <sub>3</sub>	4.88
Fe <sub>2</sub> O <sub>3</sub>	3.47
MgO	3.20
SO <sub>3</sub>	3.25
Na <sub>2</sub> O	0.02
K <sub>2</sub> O	0.44

**(b) Aggregates**

Sampling of aggregates was carried out in accordance with the requirements of BS 1881-101:2011. The coarse aggregates were sampled from natural quart site in Mukono district while sand was delivered from the shores of Lake Victoria. After sampling, 2 tonnes of each material was transported to Teclab laboratory using Sinotruk HOWO 8X4 Dumper 420HP Dump Truck. Additional quality requirements in accordance with the specification for aggregates from natural sources for concrete given in BS 882:1992 were specified to ensure compliance. The fractions from 20 to 4.75 mm was used as coarse aggregate while those fractions from 4.75 mm to 150 microns were specified for use as fine aggregate. The coarse aggregates used were machine crushed aggregate of cuboidal shape and carefully processed to proper size grading and relatively free of such deleterious substances as clay, salts, and organic matter by sieving.

### **(c) Water**

Water is an important constituent of concrete as it actually participates in the hydration (chemical reaction with cement) process. Since it gives the strength to cement concrete, the quantity and quality of the water must meet the required standards. Potable tap water which was free from any injurious amounts of acids, oils, alkalis, salts, sugars and organic materials available in the laboratory with pH value of  $7.0 \pm 1$  and conforming to the requirements of BS EN 1008:2002. was used for mixing concrete and curing the specimens. Tap stand of National Water and Sewerage Corporation (NW&SC) Kampala branch was the source of water.

### **3.3.2 Experimental Setup**

A control mix of ratio 1:2:3 batched by mass using a water-cement ratio of 0.50 was used. The control mix was produced using OPC only as binder while in other mixes, crushed ceramic and porcelain clay tile powder was used to partially replace 5, 10, 15, 20, 25 and 30% by mass of ordinary Portland cement in the control (conventional) mix. Laboratory tests were carried out on both fresh and hardened concrete. As a measure of workability, Slump test was carried out on the fresh concrete for all concrete mixes. For the hardened concrete, the compressive strength and splitting tensile strength tests were carried out in accordance with the appropriate standards. Test specimen (cubes and cylinders) were taken from the moulds after 24 hours of casting and then cured for 7, 14, and 28 days prior to testing. The performance of concrete with various treatments at different ages was monitored to establish the optimal mix. The flow chart for evaluating the performance of concrete with ceramic and porcelain clay tile powders as partial cement replacements is shown in Figure 3.6.

The study was operated by varying amounts of tile powder in concrete production by either weight and volume or the percentage of concrete.

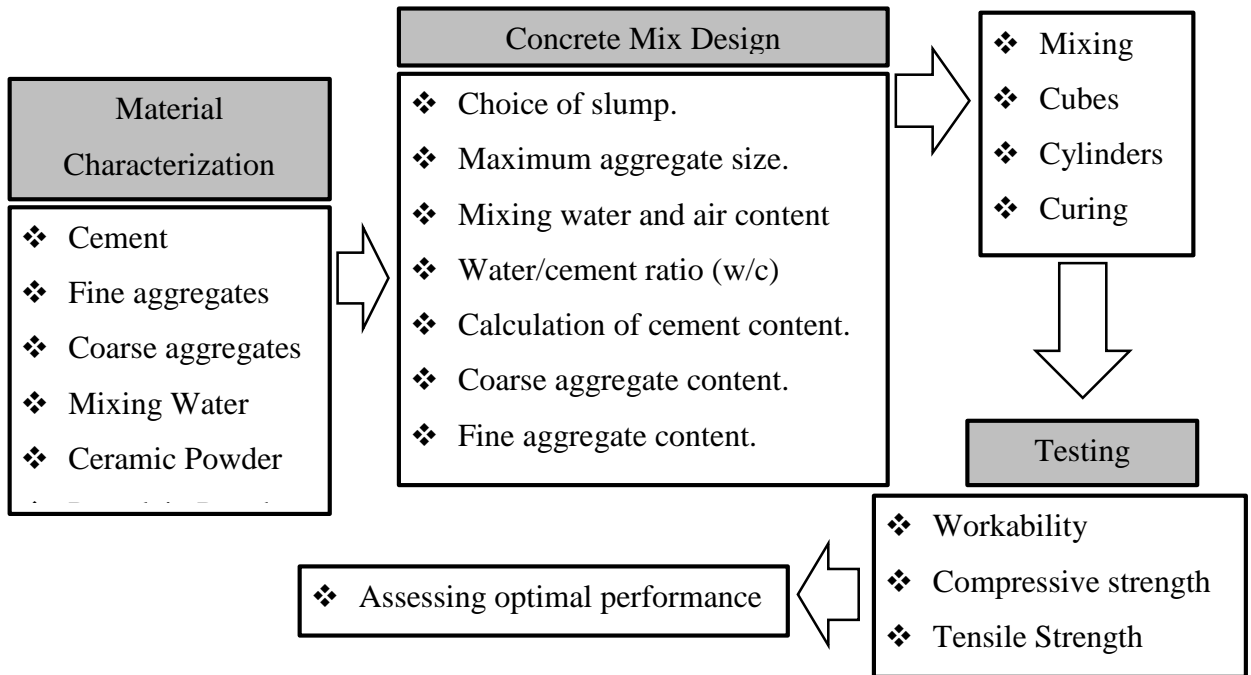

Figure 3.6: Flow chart for evaluating the performance of concrete mix obtained from ceramic and porcelain clay tile powders as partial cement substitutes.

### 3.3.3 Data Collection Procedure

#### (a) Material characterisation

The physical properties of coarse aggregate were investigated in accordance with the corresponding standards as presented in Table 3.5. A plot of cumulative percentage passing against the sieve sizes done on a graph containing the sieve envelope was drawn to classify the aggregates.

Table 3.5: Physical properties of aggregates

Property	Standard
Particle size distribution — Sieve Analysis	BS EN 933-2-2012
Specific Gravity	BS EN 1097-6-2013
Moisture Content	BS EN 882:1992
Water absorption	BS EN 1097-6-2013
Bulk Density	BS EN 1093-3-2013
Silt Content	BS EN 933-1-2012

**(b) Mix design**

American Concrete Institute (ACI) methods of concrete mix design method ACI 211.1-81 (1997) was used. The method is based on the strength, at a given age, of fully compacted concrete, cured under standard condition, is governed by water: cement ratio ( $W_C$ ) and type of cementitious material used. Also, the amount of water required per unit volume of concrete for a given consistency and with a given material is substantially constant regardless of cement content,  $W_C$  or proportions of aggregate and cement. The main factors determining the amount of water are aggregate properties, cement properties and maximum stone size. In addition, for any particular concrete mix and combination of materials, there is an optimum stone content which depends on size, shape and compacted bulk density of the stone, fineness modulus of sand and desired consistence of concrete. Finally, the volume of compacted concrete produced by any combination of materials must be equivalent to the sum of the absolute volumes of cement and aggregates plus the volume of water and that of entrapped or entrained air.

Batching was done by mass for cement, aggregates and waste powders while water was measured in litres. Mixing was done in a tilting drum mixer (laboratory type). The specimens were casted and cured in accordance with the specifications of BS EN 12390-2-2009. The inside surfaces of the moulds were cleaned, dried and oiled in order to prevent development of bond between the moulds and the concrete specimen.

**(c) Workability of fresh concrete [BS EN 12350-2-2009]**

This Part of the British Standard describes a method for determination of slump of cohesive concrete of medium to high workability. This particular method applies to plain and air-entrained concrete, made with heavy aggregates, normal weight or lightweight having a nominal maximum size of 40 mm or less but not to aerated and no-fines concrete. The definitions given in BS 5328, BS 1881-101 and BS 5497-1 apply for the purposes of this part of this British Standard.

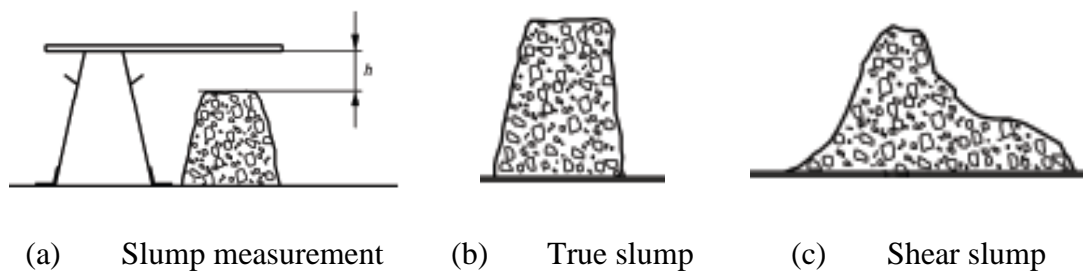

Figure 3.7: Slump measurement and its forms.

The test is only valid if it yields a true slump (slump in which the concrete remains substantially intact and symmetrical as shown in Figure 3.7(a) of the standard). If the specimen shears, as shown in Figure 3.7(b), or collapses, as shown in Figure 3.7(c) of the standard, take another sample and repeat the procedure. The true slump was



recorded to the nearest 5 mm. The slump cone apparatus with dimensions in millimetres (mm) is shown in Figure 3.8.

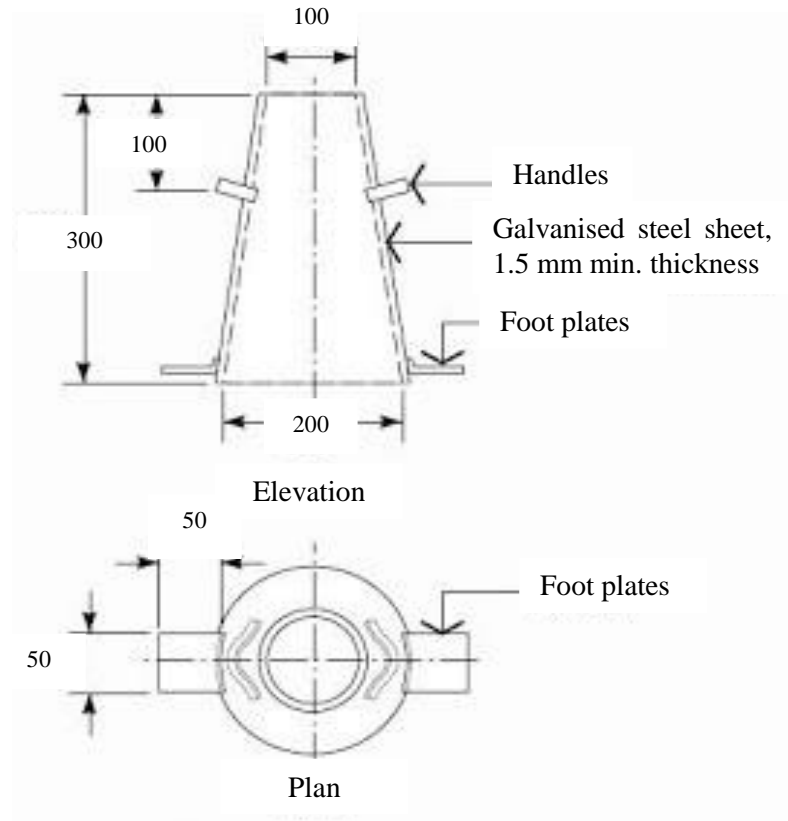

Figure 3.8: Slump cone apparatus.

**(d) Compressive and tensile strength**

The compressive strength was according to BS EN 12390-3-2009 and the splitting tensile strength test was conducted in accordance to BS EN 12390-6-2009. The testing equipment was the Universal Testing Machine (UTM) as specified in BS 1881-115-2011 (Figure 3.9).

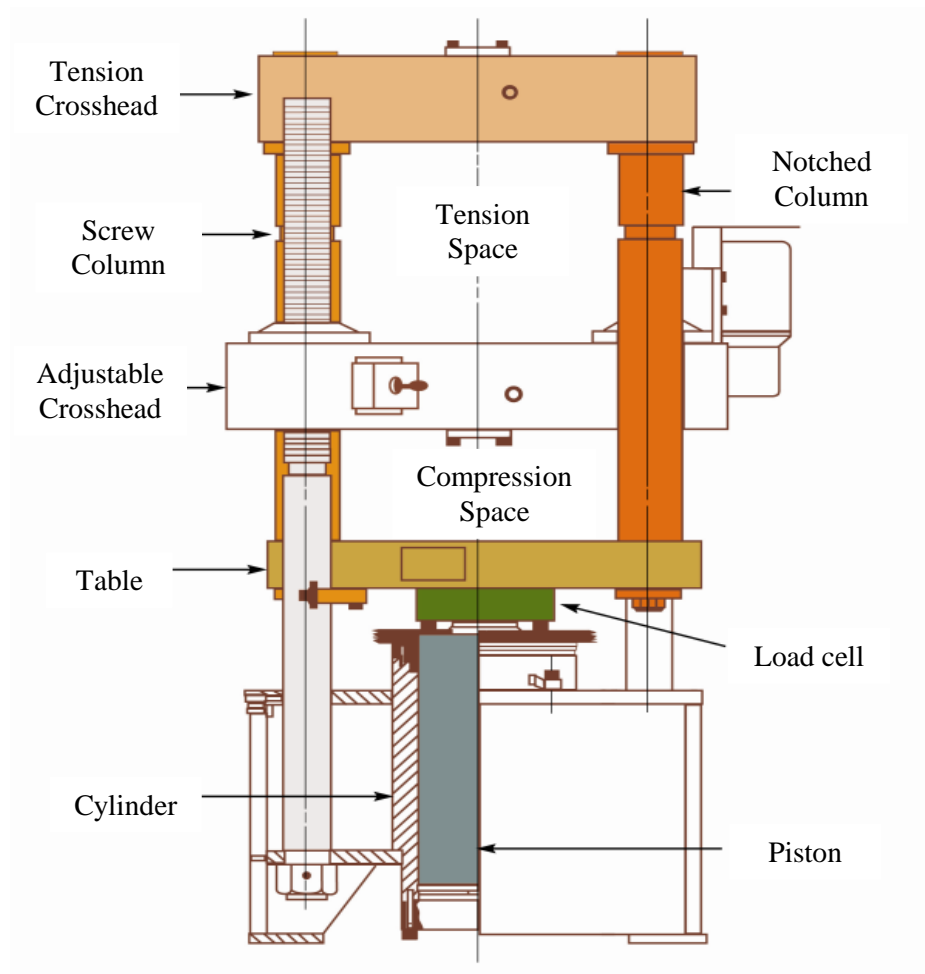

Figure 3.9: Universal testing machine for determining strength of concrete.

### 3.3.4 Data Processing and Analysis

The data obtained from material characterization was analyzed using the methods of analysis specified in the respective standards. The absolute volume of material is the total volume of solid matter in all the particles, and is calculated from the mass and the particle relative density as expressed by Equation (3.1). In the equation,  $V$  is absolute volume in  $m^3$ ,  $M$  is mass of the material in kg and  $D$  is the density of the material in  $kg/m^3$ .

$$V = \frac{M}{D \times 1000} \quad (3.1)$$

Slump was specified as dependent on method of concrete transportation, placing and compacting. The type of cement, maximum water cement ratio, ( $W_c$ ) and minimum cement content were also specified. The density of concrete and other characteristics were obtained from the manufacture's manual and cement content was calculated using Equation (3.2). In this equation,  $C$  is the cement content in kg,  $W$  is the water content also in kg and  $W_c$  is the water cement ratio.

$$C = W/W_c \quad (3.2)$$

Using excel sheets and by iteration, masses of all the materials for the different concrete mixes were obtained. The results of workability, compressive and splitting tensile strengths were analysed in accordance with the methods specified in the respective standards. From the standards, the compressive and splitting tensile strengths of concrete were calculated using Equations 3.3 and 3.4 respectively. In these equations,  $f_{cs}$  is the compressive strength,  $f_{ts}$  is the tensile splitting strength,  $F$  is the maximum load at failure,  $L$  is the length of the line of contact of the specimen,  $d$  is the designated cross-sectional dimension and  $A_c$  is the cross-sectional area of the specimen on which the compressive force acts.

$$f_{cs} = \frac{F}{A_c} \quad (3.3)$$

$$f_{ts} = \frac{2F}{\pi Ld} \quad (3.4)$$

Using excel spreadsheet, graphs were plotted and regression analysis was carried out to study the relationship between variables.

### **3.4 Analysing the Cost-Benefit of Using Ceramic and Porcelain Powders in Concrete**

#### **3.4.1 Data Collection Procedure**

The aim of this objective was to compare the cost of one cubic metre of optimal concrete mix with the cost of the same quantity conventional concrete mix. The relevant data was collected as elucidated in Sections 3.2.2 and 3.3.3. The Civil Engineering Standard Method of Measurement (CEMM) was used to evaluate the cost of concrete production. A conclusion was drawn based on the difference in cost saving between the two options.

As concerns the benefits, Environmental Impact Assessment (EIA) was carried out. The aspects of the EIA included: the objectives of the study; the technology, procedures and processes used in the implementation of the study; the materials to be used in the implementation of the study objectives; the products, by-products, and waste to be generated by the production of concrete alternative ingredients; reviewing existing legal and institutional framework related to waste management; identifying and analyse alternative options for the proposed waste management systems and developing mitigation measures for the negative impacts of the study. Two indicators (abiotic depletion and global warming) were used to evaluate the environmental impacts.

The following information was required to define cost per unit of work: correct information of the market price of the materials at the time of need to be used as a prime cost, correct information of the rates of various categories of skilled and

unskilled labourers as wage rates to be used for daily work rate, output of labourers per day for various types of items (productivity), correct information of the rates of various categories of equipment and tools as rental rates to be used for major items of rates.

Total cost per unit of work (TC) was grouped into two components; direct cost and indirect cost. The direct cost (DC) included cost due to material, cost due to labour, cost due to equipment, whereas the indirect cost (IC) covers overhead costs, and contractor's profit. Overhead costs for general office facility, rents, taxes, electrical light, water, and other miscellaneous items were not considered in the analysis.

### 3.4.2 Data Analysis

The cost benefit analysis was done to compare the cost of housing construction with concrete having 0% cement substitute and that with the optimal concrete mix. These assessments were calculated using Equations 3.5, 3.6 and 3.7. In these equations,  $C_r$  is percentage cost reduction,  $AD_r$  is the percentage abiotic depletion reduction,  $(CO_2)_r$  is the percentage carbon dioxide reduction,  $C_0$  is the material cost of conventional concrete mix,  $C_{20}$  is the material cost of optimal concrete mix,  $E_c$  is the energy consumption required for production of 1 kg of cement,  $E_w$  is the energy consumption required for production of 1 kg of waste powders,  $CE_c$  is the CO<sub>2</sub> emission in production of one ton of cement and  $CE_w$  is the CO<sub>2</sub> emission in production of one ton of waste powders.

$$C_r = \left( \frac{C_0 - C_{20}}{C_0} \right) \times 100 \% \quad (3.5)$$

$$AD_r = \left(1 - \frac{E_c - E_w}{E_c}\right) \times 100 \% \quad (3.6)$$

$$(CO_2)_r = \left(1 - \frac{CE_c - CE_w}{CE_c}\right) \times 100 \% \quad (3.7)$$

In addition, cost and environmental impacts were also compared using graphs plotted in Microsoft excel spreadsheet.

## CHAPTER FOUR

### RESULTS AND DISCUSSION

#### 4.1 Engineering Properties of Crushed Ceramic and Porcelain Clay Tile Powders

The physical properties of crushed ceramic and porcelain clay tile powders in comparison with those of ordinary Portland cement are presented in Table 4.1.

Table 4.1: Physical properties of ceramic and porcelain clay tile powders.

Physical property	Portland cement	Ceramic powder	Porcelain powder
Specific gravity	3.15	2.95	3.11
Consistency (%)	30	32.5	35.0
Initial setting time (minutes)	60 minimum	70	45
Final setting time (minutes)	540 maximum	475	320
Colour	Grey	Reddish brown	Grey

With reference to Table 4.1, it is seen that the densities of both ceramic and porcelain clay tile powders is less than that of ordinary Portland cement by 6.8 and 1.3% respectively. This implies that during hydration of binder, increase in ceramic and porcelain powders will increase the volume and thereby increase the water demand. It is also observed that the normal consistency of ceramic and porcelain powders is greater than that of Portland cement by 7.7 and 14.3% respectively. Since the quantity of water required to produce a cement paste of standard consistency is less than that required for ceramic and porcelain powders, it implies that increase in waste powders would compromise the strength of concrete. Further reference to Table 4.1 indicates that the setting time of both ceramic and porcelain powders is more than that of Portland cement. Since the initial setting time is higher, increase in ceramic and

porcelain powders will cause further delay in the process of hydration or hardening. Additionally, since the final setting time of ceramic and porcelain powders is more than that of cement, increase in waste powders implies that the time taken for paste to completely lose its plasticity will also increase. Finally, both Portland cement and porcelain powder are grey in colour while ceramic powder is reddish brown. This colour difference could be attributed to the varying percentage composition by mass of iron oxide.

Figure 4.1 compares the chemical components by mass of ceramic and porcelain powders with ordinary portland cement. About 95% of Portland cement clinker is made of combinations of four oxides. These are: lime (CaO), silica(SiO<sub>2</sub>), alumina (Al<sub>2</sub>O<sub>3</sub>), and iron oxide (Fe<sub>2</sub>O<sub>3</sub>). Other, so-called minor constituents or impurities include, magnesia; sodium, and potassium oxides.

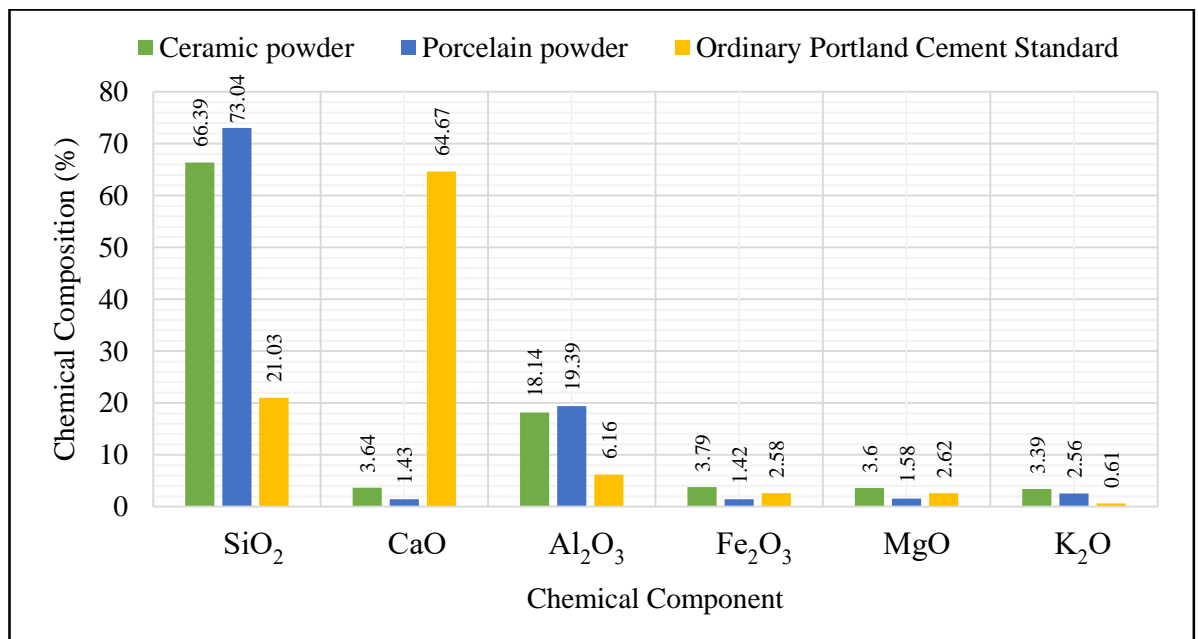

Figure 4.1: Chemical composition of cement, and ceramic and porcelain powders.



Reference to Figure 4.1 shows that the quantity of silica in ceramic and porcelain powders exceeds that of Portland cement by 68.3 and 71.2% respectively. Sufficient quantity of silica is responsible for the formation of dicalcium and tricalcium silicate during the hydration process. Thus significant addition of ceramic and porcelain powders will aid the formation of the binder gel thereby imparting strength to concrete.

It is also seen that the presence of calcium oxide (lime) in cement is much higher than compared with ceramic and porcelain powders. Lime is required to form silicates and aluminates of calcium which are responsible for strength of the paste. Therefore, deficiency in lime reduces the strength of cement and causes its quick setting. For this reason, as ceramic and porcelain powders replace cement in concrete, the strength is expected to reduce. In addition, excess lime makes cement unsound, causing it to expand and disintegrate. Therefore, addition of ceramic and porcelain powders can improve these properties.

Furthermore, it is noted that the aluminium oxide (alumina) content in ceramic and porcelain powders exceeds that of Portland cement by 66.0 and 68.2%. Since alumina imparts quick setting property to the cement, increase in ceramic and porcelain powders would weaken the concrete. Finally, the presence of iron oxide in the three binders acts as a flux which at high temperatures reacts chemically with calcium and aluminium to form tricalcium alumino-ferrite, which is responsible for colour and hardness.

Further reference to Figure 4.1, it is clear that both ceramic and porcelain clay tile powder contain, respectively, 88.3 and 93.9% of  $\text{SiO}_2$ ,  $\text{Fe}_2\text{O}_3$  and  $\text{Al}_2\text{O}_3$ . In a nutshell, it can be concluded that the combined percentage of silica ( $\text{SiO}_2$ ), iron oxide ( $\text{Fe}_2\text{O}_3$ ), and alumina ( $\text{Al}_2\text{O}_3$ ) for both crushed ceramic and porcelain clay tile powder was meeting the 70% minimum requirement of ASTM C 618 for a good pozzolan. The presence of Silica ( $\text{SiO}_2$ ), Iron Oxide ( $\text{Fe}_2\text{O}_3$ ) and Alumina ( $\text{Al}_2\text{O}_3$ ) in the pozzolan are responsible for the formation of cementitious compounds when they react with lime.

## 4.2 Performance of Concrete Mix obtained from Crushed Ceramic and Porcelain Clay Tile Powders as Partial Cement Substitutes

### 4.2.1 Material Characterization and Concrete Mix Design

#### (a) Fine aggregates

The particle size distribution of fine aggregates is presented in Figure 4.2. and the results show that all the aggregates passed through the 20 mm sieves.

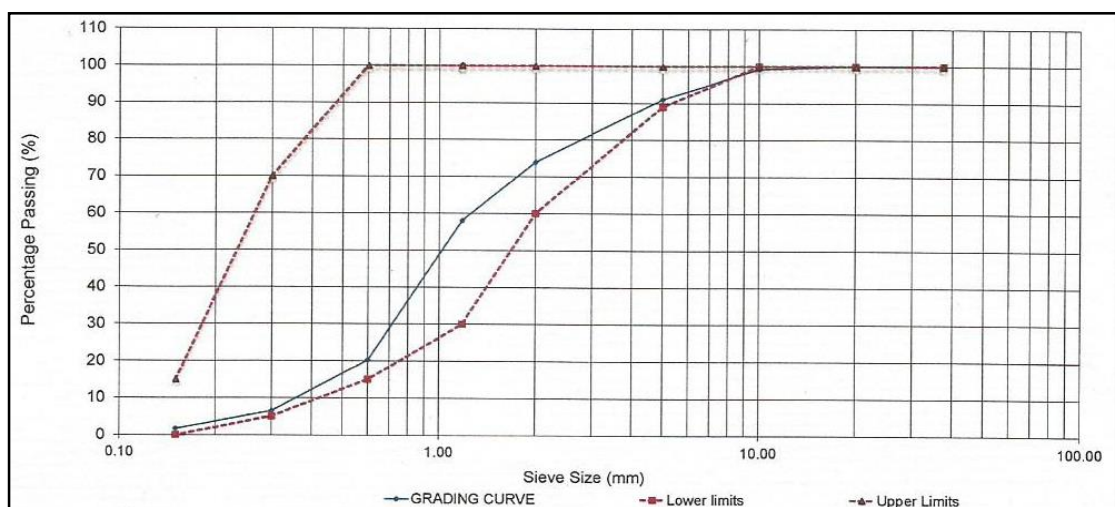

Figure 4.2: Particle size distribution of fine aggregates.

Figure 4.2 show that the grading of fine aggregates lies within the grading envelop and thus were uniformly graded since they are relatively evenly retained on each sieve. According to the requirements of BS 410: 1881, well and uniformly graded aggregates enhance the workability of concrete by minimizing voids in the mix as they are filled by smaller particles of the aggregates and no bleeding. The natural moisture content of fine aggregates was 4.4%. According to Abrams Law, which states that, all other things being equal, compressive strength of concrete is dependent on the ratio of mass of water to cementitious material, this implies that the aggregates are sufficient as there will be no initial absorption of water intended for hydration. The specific gravity was  $2.6 \text{ Mg/m}^3$  and silt content was 1.5% which is a low value implying that the fine aggregates was clean.

**(b) Coarse aggregates**

A plot of cumulative percentage passing against the sieve sizes done with the sieve envelope is shown in Figure 4.3.

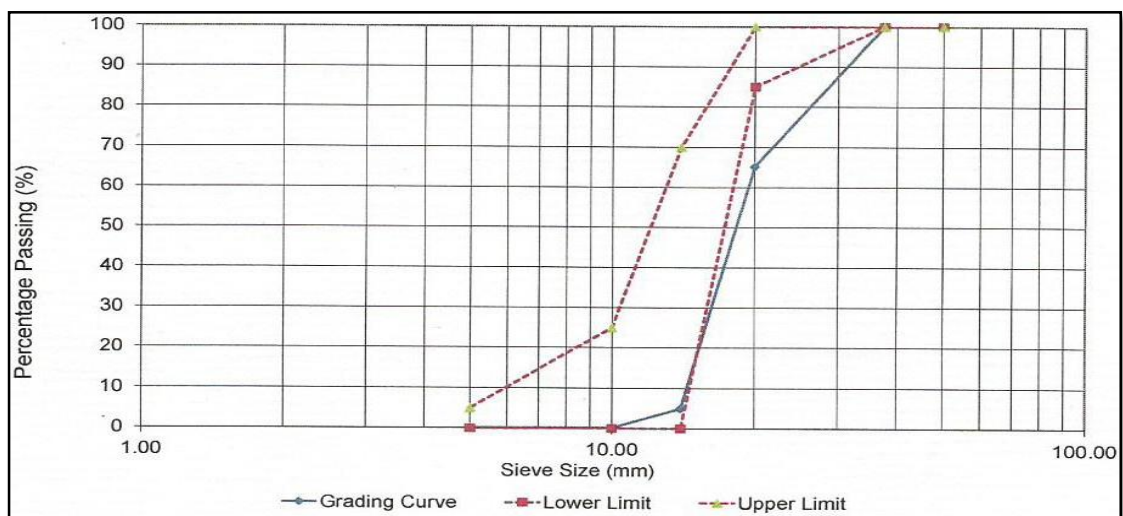

Figure 4.3: Particle size distribution of coarse aggregates.

With reference to Figure 4.3, it is clear that the coarse aggregates constituted of fractions from 20 to 4.75 mm. The aggregates which were machine crushed angular granite metal of 20 mm nominal size from the local source were found to be free from impurities such as dust, clay particles and organic matter among others. Since the smaller sizes lie within the grading envelope while the larger sizes were outside the same, it can be noted that the coarse aggregates. This will then have a bearing on the mechanical properties of the hardened concrete. In addition, the specific gravity, water absorption, and bulk density were 2.7 Mg/m<sup>3</sup>, 1.1% and 1.5 g/m<sup>3</sup> respectively.

**(c) Concrete mix design proportions**

The mix proportions for various percentage replacement levels are shown in Table 4.2.

Table 4.2: Concrete trial mix proportions for test specimen

Percentage Replacement (%)	Mass of constituents (kg)			
	Cement	Ceramic and Porcelain	Sand	Coarse aggregates
0	1.850	0	4.271	5.283
5	1.758	0.092	4.271	5.283
10	1.665	0.185	4.271	5.283
15	1.572	0.278	4.271	5.283
20	1.480	0.370	4.271	5.283
25	1.388	0.462	4.271	5.283
30	1.295	0.555	4.271	5.283

The details presented in Table 4.2 are presented in Appendix A. These values present a control mix of ratio 1:2:3 batched by mass using a water-cement ratio of 0.50. The control mix was produced using OPC only as binder while in other mixes, crushed ceramic and porcelain clay tile powder was used to replace 5, 10, 15, 20, 25 and 30%

of the mass of ordinary portland cement in the control mix. It is also observed that the quantity of fine and coarse aggregates remains constant for all mixes, implying that only binder content was varying as the study aimed at replacing cement alone.

#### 4.2.2 Workability of Fresh Concrete

The results of slump test are presented in Figure 4.4.

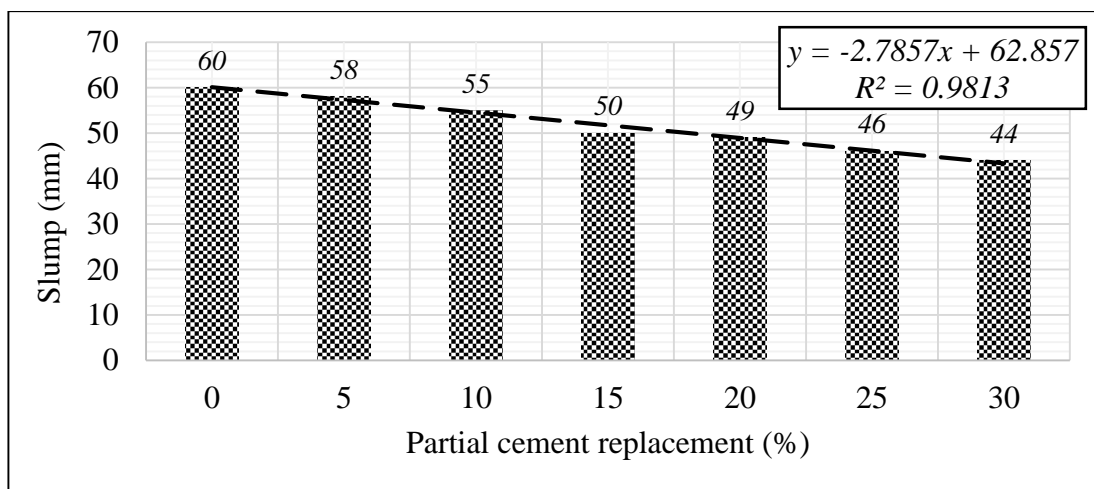

Figure 4.4: Variation of slump with percentage cement replacement

From the results presented in Table 4.4, it can be seen that as the percentage replacement of ordinary Portland cement with ceramic and porcelain clay tile powders increases, the workability of concrete decreases. There was a reduction in the workability levels as reported by a reduction in the slump values from 60 mm for normal concrete at percentage reductions of 3.33, 8.33, 16.67, 18.33, 23.33 and 26.67% for 5, 10, 15, 20, 25 and 30% partial cement replacement respectively as compared to the control. Replacing cement by an equal mass of ceramic and porcelain clay tile powders causes an increase in volume since the density of cement is higher than that of crushed ceramic and porcelain clay tile powder.

This therefore increases the water demand and as the crushed ceramic and porcelain clay tile powder content increases the workability reduces since the quantity of water remains the same for all mixes. The relationship between slump and partial cement substitute is expressed by Equation 4.1. In this equation,  $S_l$  is the slump in mm and  $C_{sub}$  is the percentage partial cement replacement.

$$S_l = -2.7857C_{sub} + 62.857 \quad (4.1)$$

In the relationship expressed by Equation 4.1,  $R^2 = 0.9813$  implying that slump and cement replacement relate strongly. The slope of Equation 4.1 is negative thus showing that slump reduces with increase in cement substitute. In addition, the reduction in the workability of fresh concrete may be caused by an adhesion within the concrete and holding the other ingredients of concrete together impeding easy flow of water as was reported by Nibudey *et al.* (2014).

### **4.2.3 Compressive Strength of Hardened Concrete**

The result for compressive strengths for various cement replacement levels at different ages is presented in Figure 4.5. A line marking the target strength is also indicated in the same Figure.

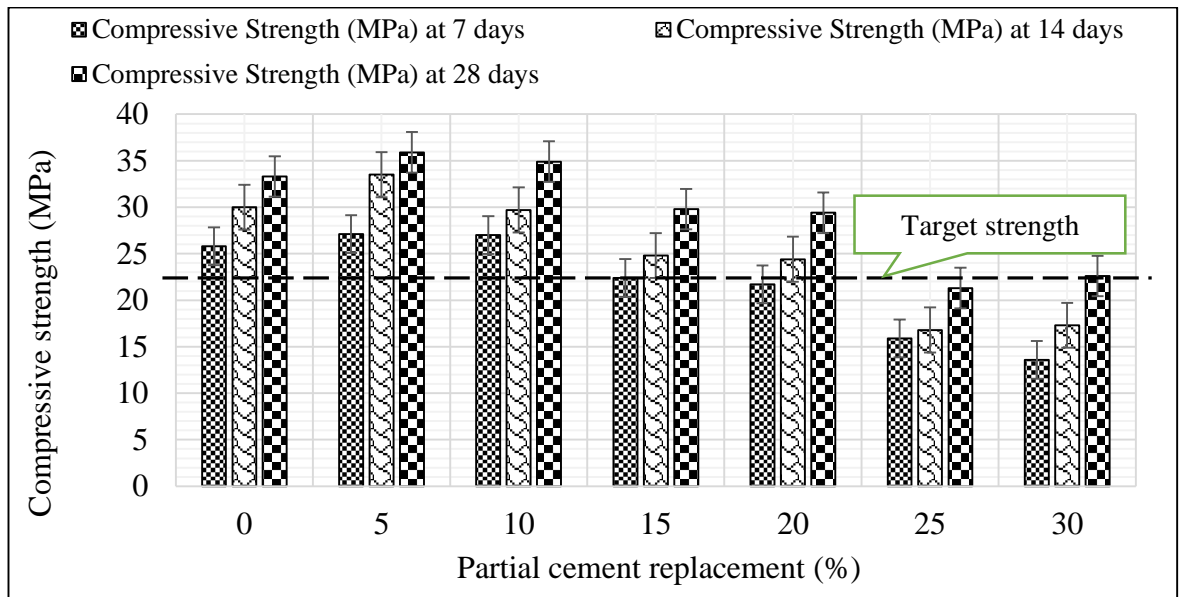

Figure 4.5: Compressive strengths for various replacement levels at different ages.

Concrete derives its strength from the pozzolanic reaction between silica in pozzolan and the calcium hydroxide liberated during the hydration of OPC. In the very first period after the adsorption of water on the surface of the dry powder, the dissolution of part of the inorganic phases starts to occur. Very soon, however, new silicate and aluminate hydrated phases begin to precipitate from the solution on the existing grains, thus favouring the further dissolution of the anhydrous phases through an incongruent process. An amorphous calcium silicate hydrate, referred to as C-S-H, having the properties of a rigid gel responsible for the binding characteristics of the cement is, is formed during the hydrated phase. The C-S-H gel is the most abundant reaction product and it occupies about 50% of the paste volume. A secondary product of the hydration process of cement is crystalline portlandite ( $\text{Ca}(\text{OH})_2$ ). The reaction of the silicate and aluminate phases with water is an exothermic process. Because the C-S-H gel forms a continuous layer that binds together the original cement particles into a cohesive whole, it is responsible for most of the engineering properties of cement

paste. The ability of the C-S-H gel to act as a binding phase arises from its nanometer-level structure.

From Figure 4.5, it is seen that at low percentages of replacement, the quantity of silica is low, therefore, despite the large quantity of calcium hydroxide liberated due to the relatively large quantity of portland cement, only a limited quantity of C-S-H can be formed. However, at high percentage replacement, the quantity of pozzolan in the mix increases. C-S-H formed reduces due to liberation of a small quantity of  $\text{Ca}(\text{OH})_2$  from the hydration of the relatively low quantity of portland cement available. The strength of concrete at both low and high percentage replacement is therefore low. It can also be concluded that the strength of concrete depends on the relative proportions of silica in crushed ceramic and porcelain powder and ordinary portland cement available.

In addition, the optimum reaction takes place at 5% replacement of OPC hence the rate of strength gain with respect to time is highest for concrete with 5% replacement of OPC by crushed ceramic and porcelain powder. The variation of compressive strength of concrete is presented in Figure 4.6. The target compressive strength at 28 days was achieved up to 20% replacement of cement with crushed ceramic and porcelain clay tile powder beyond which the addition reduces the strength. This trend is similar at all ages when specimen were testes testing. It is also seen that the strength of concrete increases with age.



Furthermore, Figure 4.6 presents predictive curves for compressive strengths for various cement replacement levels at different ages of curing. From these curves, relationships for compressive strength against partial cement replacement were developed for 7, 14 and 28 days of curing. The strength of the relationship was also determined.

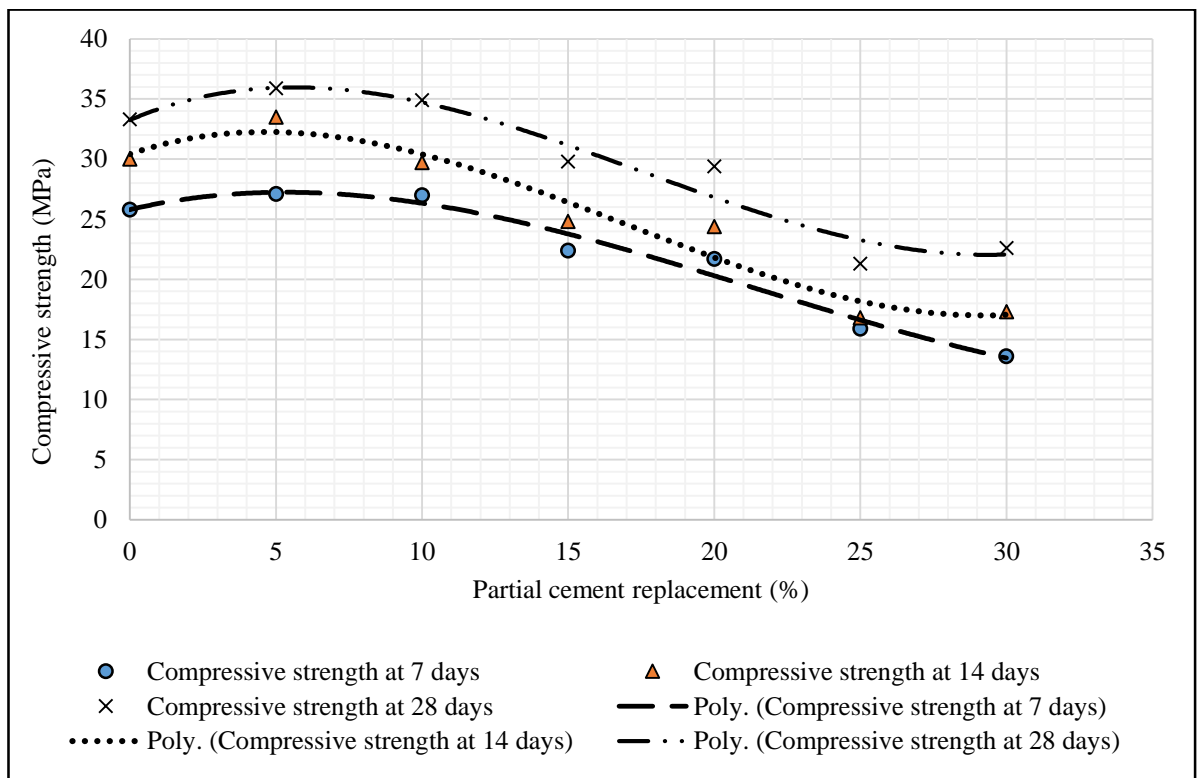

Figure 4.6: Prediction of compressive strengths for various cement replacement levels at different ages of curing.

The relationship between compressive strength and partial cement replacement is expressed by Equation 4.2. In this equation,  $f_{ck, 7days}$  is the compressive strength of concrete after 7 days while  $C_{sub}$  is the percentage partial cement replacement.

$$f_{ck, 7days} = 0.001C_{sub}^3 - 0.061C_{sub}^2 + 0.5713C_{sub} + 25.798 \quad (4.2)$$

The relationship expressed by Equation 4.2 is quadratic (polynomial of second degree) with  $R^2 = 0.972$  implying that compressive strength at 7 days and cement replacement relate strongly.

The relationship between compressive strength and partial cement replacement is expressed by Equation 4.3. In this equation,  $f_{ck, 14days}$  is the compressive strength of concrete after 14 days while  $C_{sub}$  is the percentage partial cement replacement.

$$f_{ck, 14days} = 0.0021C_{sub}^3 - 0.1049C_{sub}^2 + 0.8419C_{sub} + 30.405 \quad (4.3)$$

The relationship expressed by Equation 4.3 is quadratic (polynomial of third degree) with  $R^2 = 0.9453$  implying that compressive strength at 14 days and cement replacement relate strongly.

The relationship between compressive strength and partial cement replacement is expressed by Equation 4.4. In this equation,  $f_{ck, 28days}$  is the compressive strength of concrete after 28 days while  $C_{sub}$  is the percentage partial cement replacement.

$$f_{ck, 28days} = 0.0021C_{sub}^3 - 0.1095C_{sub}^2 + 1.033C_{sub} + 33.25 \quad (4.4)$$

The relationship expressed by Equation 4.4 is quadratic (polynomial of fourth order) with  $R^2 = 0.9363$  implying that compressive strength at 28 days and cement replacement relate strongly.

#### **4.2.4 Splitting Tensile Strength of Hardened Concrete**

Figure 4.7 shows the splitting tensile strengths for various cement replacement levels at different ages. Three test specimens were cast for each proportion and used to

measure the tensile strength for each test condition using the Universal Testing Machine (UTM). The average value was considered. The average values of 3 specimens for each category at the ages of 7, 14 and 28 days are shown in the same Figure.

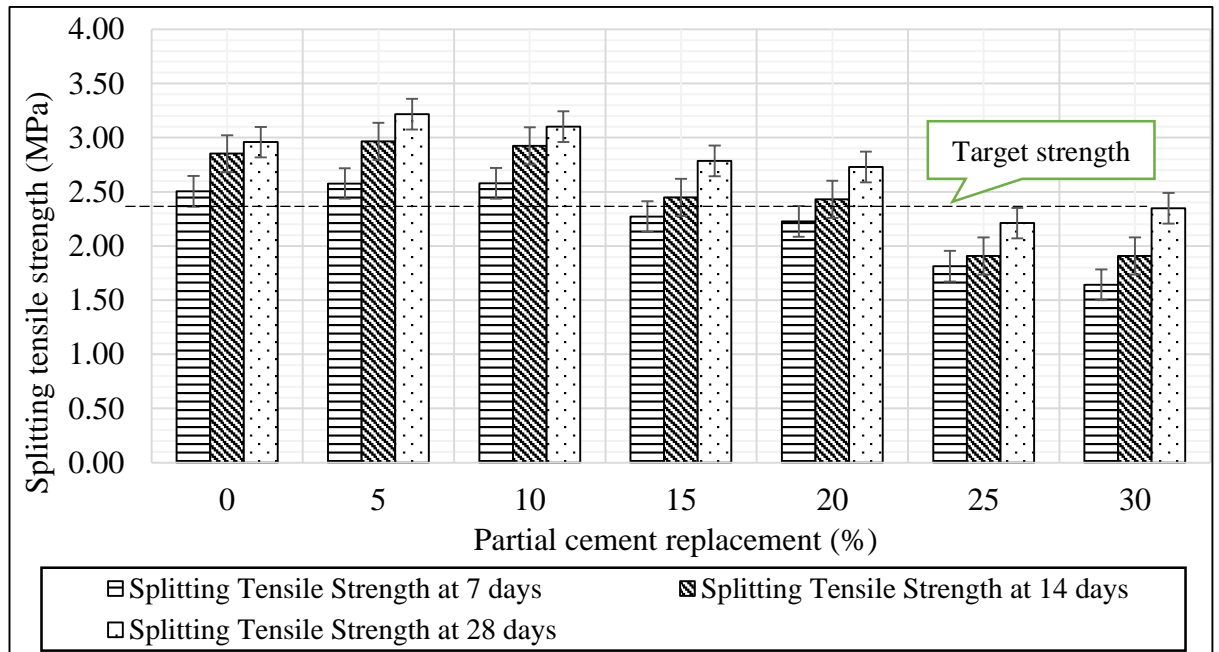

Figure 4.7: Tensile strengths for various cement replacement levels at different ages.

The results show that there was an improvement in the tensile splitting strength values up to 10% cement replacement with ceramic and porcelain powder at 7, 14 and 28 days curing times. The target tensile strength was achieved up to 20% cement replacement with ceramic and porcelain powder. This implies that the absence of cracking which is of considerable importance in maintaining the continuity of concrete structures and in many instances is relevant in the preventing corrosion of reinforcement can be achieved up to 20% cement replacement level.

Furthermore, Figure 4.8 presents curves upon which relationship between splitting tensile strengths for various cement replacement levels at different ages of curing is predicted in Equations 4.5, 4.6 and 4.7.

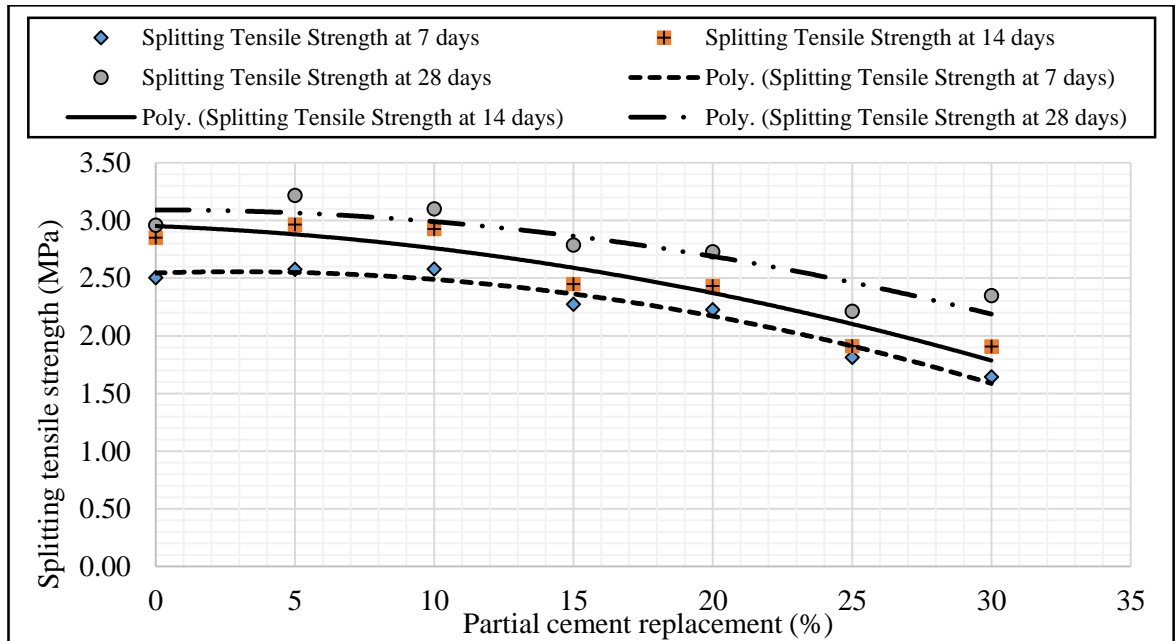

Figure 4.8: Prediction of splitting tensile strengths for various cement replacement levels at different ages of curing.

The relationship between splitting tensile strength and partial cement replacement is expressed by Equation 4.5. In this equation,  $f_{ctk, 7days}$  is the splitting tensile strength of concrete after 7 days while  $C_{sub}$  is the percentage partial cement replacement.

$$f_{ctk, 7days} = -0.0013C_{sub}^2 + 0.0076C_{sub} + 2.5446 \quad (4.5)$$

The relationship expressed by Equation 4.2 is quadratic (polynomial of second degree) with  $R^2 = 0.9588$  implying that compressive strength at 7 days and cement replacement relate strongly.

The relationship between compressive strength and partial cement replacement is expressed by Equation 4.6. In this equation,  $f_{ctk, 14days}$  is the compressive strength of concrete after 14 days while  $C_{sub}$  is the percentage partial cement replacement.

$$f_{ctk, 14days} = -0.001C_{sub}^2 - 0.0094C_{sub} + 2.951 \quad (4.6)$$

The relationship expressed by Equation 4.6 is quadratic (polynomial of third degree) with  $R^2 = 0.9019$  implying that compressive strength at 14 days and cement replacement relate strongly.

The relationship between compressive strength and partial cement replacement is expressed by Equation 4.7. In this equation,  $f_{ck, 28days}$  is the compressive strength of concrete after 28 days while  $C_{sub}$  is the percentage partial cement replacement.

$$f_{ck, 28days} = -0.001 C_{sub}^2 - 0.0001C_{sub} + 3.0908 \quad (4.7)$$

The relationship expressed by Equation 4.7 is quadratic (polynomial of fourth order) with  $R^2 = 0.8208$  implying that compressive strength at 28 days and cement replacement relate strongly.

The relationship between compressive strength and splitting tensile strength of concrete obtained from ceramic and porcelain powders as partial replacement of cement is shown in Figure 4.9.

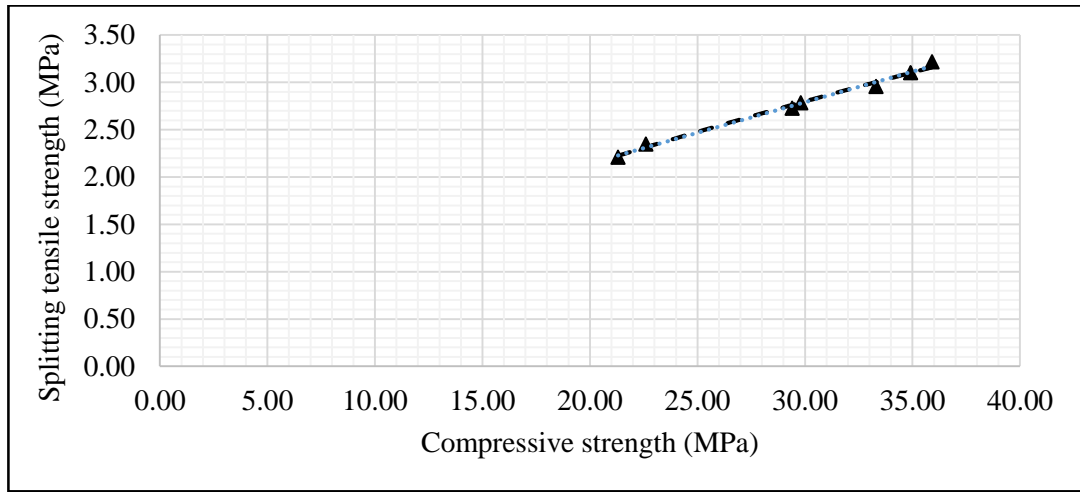

Figure 4.9: Relationship between compressive and splitting tensile strengths.

With reference to Figure 4.9,  $R^2 = 0.9925$  signifying that the relationship between compressive and splitting tensile strengths is strong. This relationship is expressed by Equation 4.8, where  $f_{ctk}$  is the characteristic tensile strength while  $f_{ck}$  is the characteristic compressive strength.

$$f_{ctk} = 0.2849 \times f_{ck}^{(0.6718)} \quad (4.8)$$

Equation 4.8 is similar to Equation 2.5 which according to Eurocode 2 is the empirical relationship between compressive and tensile strengths of concrete. This Equation can be used to generate similar values as those in Table 3.1 of Eurocode 2.

### 4.3 Cost benefit of using Crushed Ceramic and Porcelain Clay Tiles as Partial Replacement of Cement in concrete

#### 4.3.1 Cost Assessment

First and foremost, the material cost of obtaining conventional and that of the optimal mix (20% cement replacement level) is presented in Tables 4.3 and 4.4 respectively.

Table 4.3: Material cost for conventional concrete

Type and description of material	Unit	Qty	Rate (UgSh)	Cost per Unit (UgSh)
OPC, delivered and offloaded	bag	6.8	48,000	261,120
Lake sand, delivered on site	m <sup>3</sup>	0.47	45,000	21,150
Crushed angular aggregates delivered on site	m <sup>3</sup>	0.7	67,000	46,900
Tap stand of NW&SC Kampala	litre	180	42.30	7,614
			<i>Total</i>	<i>406,314</i>

Table 4.4: Material cost for concrete with 20% cement replacement

Type and description of material	Unit	Qty	Rate (UgSh)	Cost per Unit (UgSh)
OPC, delivered and offloaded	bag	5.44	48,000	261,120
Crushed clay tile powders	bag	1.36	3,125	4,250
Lake sand, delivered on site	m <sup>3</sup>	0.47	45,000	21,150
Crushed angular, delivered	m <sup>3</sup>	0.7	67,000	46,900
Tap stand of NW&SC Kampala	litre	180	42.30	7,614
			<i>Total</i>	<i>341,034</i>

The values in Tables 4.3 and 4.4 are presented in Appendix C1. From both Tables, it is seen that the quantity, unit rate and cost of water and aggregates remains constant while that of cement is varying due to inclusion of ceramic and porcelain waste powders. In this regard, the percentage cost reduction,  $C_r$  was calculated using Equation 3.5 in which  $C_0=406,314$  and  $C_{20}=341,034$ . The cost evaluation therefore indicated that in terms of material costs, there was a reduction  $C_r = 15.2\%$  in the production of optimal concrete mix as compared to the conventional mix.

Figure 4.10 shows the relationship between material cost of production of one cubic metre of concrete with percentage partial cement replacement. The data used to generate Figure 4.10 is presented in Appendix C2. Here material cost per cubic metre for the various partial cement replacement levels was calculated.

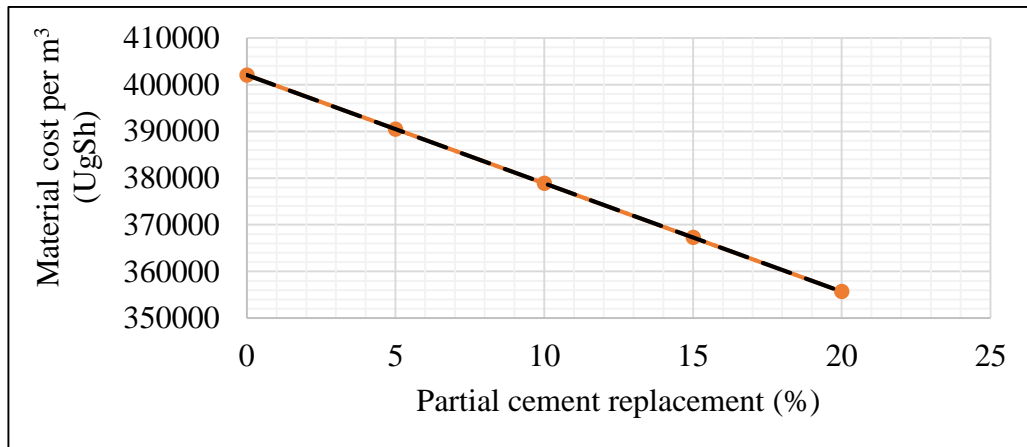

Figure 4.10: Unit cost of materials per m<sup>3</sup> for various cement replacement levels.

With reference to Figure 4.10, it is observed that as the partial cement replacement increases, the material cost decreases. Thus, it is imperative that in terms of cost, one can conveniently conclude that the use of ceramic and porcelain clay tile powders as partial replacement of cement up to 20% is feasible. This is because the cost of acquiring ceramic and porcelain clay tile powders is much less than the equivalent cost of using cement. Hence replacing cement reduces the material cost of concrete production. The relationship between material cost and partial cement replacement with ceramic and porcelain clay tile powders is expressed by Equation 4.9. In this Equation,  $M_c$  is the material cost while  $C_{sub}$  is the percentage partial cement replacement.

$$M_c = -2319.5C_{sub} + 402064 \quad (4.9)$$



The relationship expressed by Equation 4.9 is linear with negative slope and  $R^2 = 1$  implying that material cost  $M_c$  and the percentage partial cement replacement  $C_{sub}$  relate strongly.

### 4.3.2 Environmental Impact Assessment

#### (a) Abiotic depletion

Firstly, in terms of energy consumption saving, Figure 4.11 shows the comparison between cement and ceramic and porcelain waste powders. Figure 4.11 was generated from data given in Appendix D1.

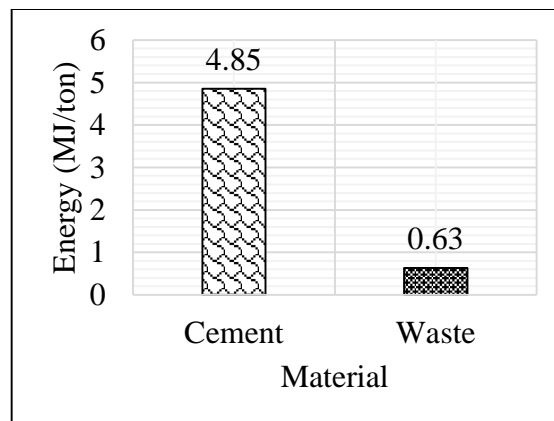

Figure 4.11: Abiotic depletion

Figure 4.11 shows that there is reduction in abiotic depletion when cement is replaced with ceramic and porcelain clay tile powders. In this regard, the percentage abiotic depletion reduction  $AD_r$  was calculated using Equation 3.6 in which  $E_c=4.85MJ/ton$  and  $E_w=0.63MJ/ton$ , energy consumption reduced by 12.8%, signifying a reduction in the production cost of ceramic and porcelain clay tile powders as compared to production of ordinary Portland cement. This is because utilization of waste material consumes much less energy since no extraction from the earth's crust

is required. Energy is only required in processing the clay tiles into powder form. Replacing cement partially with ceramic and porcelain waste powders would significantly reduce the environmental impacts of energy consumption.

**(b) Global warming**

Secondly, in terms of CO<sub>2</sub> emission saving, Figure 4.12 shows the comparison between ordinary Portland cement and ceramic and porcelain clay tile waste powders. The data used for generating this Figure is presented in Appendix D2.

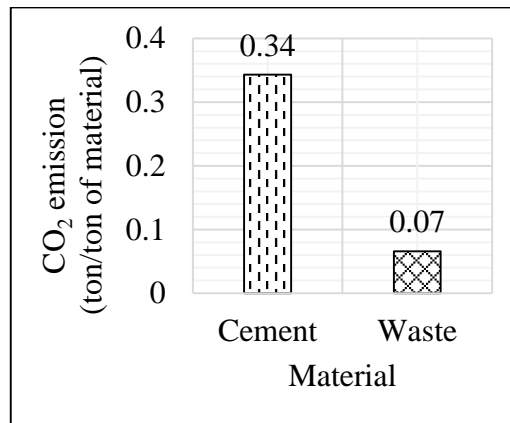

Figure 4.12: Global warming

From Figure 4.12, it is seen that production of one ton of ceramic and porcelain clay tile powders generates 0.07 ton of CO<sub>2</sub> in fuel emissions while production of one ton of cement generates 0.343 ton of CO<sub>2</sub> in fuel emissions which is responsible for global warming. The percentage carbon dioxide reduction  $(CO_2)_r$ , in production of one ton of cement viz-a-viz the CO<sub>2</sub> emission in production of one ton of waste powders was calculated using Equation 3.7, where  $CE_c = 0.343$  and  $CE_w = 0.06598$  tons per ton of material produced. It is observed that with partial replacement of cement with ceramic and porcelain powder, there is 19.2 % reduction in CO<sub>2</sub> emission in fuel consumed in

their respective production. This carbon dioxide emission reduced by 19.2% implying a significant reduction in global warming.

## CHAPTER FIVE

### CONCLUSIONS AND RECOMMENDATIONS

#### 5.1 Conclusions

- 1) The physical properties of crushed ceramic and porcelain clay tile powders are closely related. The combined percentage of silica ( $\text{SiO}_2$ ), iron oxide ( $\text{Fe}_2\text{O}_3$ ), and alumina ( $\text{Al}_2\text{O}_3$ ) for both crushed ceramic and porcelain powders was meeting the 70% minimum requirement of ASTM C 618 for a good pozzolan.

Increase in crushed ceramic and porcelain clay tile powder replacement decreased the workability of concrete. Replacement of cement with crushed ceramic and porcelain clay tile powder significantly increased the compressive strength of concrete. Replacement of 5% of the mass of cement with crushed ceramic and porcelain powders achieved the maximum compressive strength.

- 2) The 7-day, 14-day, and 28-day compressive strengths at 5% replacement respectively showed increases of 5%, 12% and 8% over the compressive strength of the control concrete at those ages.

The 28-day compressive strengths at 20% replacement showed increases of 18% compared to the target compressive strength of C25. Hence the replacement of cement using 20% crushed ceramic and porcelain powders in production of concrete gives the required strength and can be considered as optimum percentage. Further increase in the percentage addition of ceramic waste, reduces the compressive strength of concrete by 56% at 28 days.

The 28-day splitting tensile strengths was achieved up to 20% replacement and it showed increases of 8.2% compared to the target tensile strength of C25.

- 3) From the cost point of view, there was a reduction of 15.2 % between the conventional and optimal concrete mixes. Replacing cement partially with ceramic and porcelain waste powders would significantly reduce the environmental impacts of energy consumption by 12.8 %, signifying saving in abiotic resources like fuel and coal. There was also a reduction in terms of CO<sub>2</sub> emission by 19.2 %, implying reduction in global warming.

## **5.2 Recommendations**

### **5.2.1 For Possible Application**

- 1) Crushed ceramic and porcelain clay tile powders may be used to replace cement partially or even at high proportions in in the production of eco-friendly concrete.
- 2) This concrete can be applied as multi-purpose concrete that is used on a wide range of commercial and domestic construction sites as structural concrete elements such as foundations (footings).
- 3) It may also be the ideal concrete for domestic slab foundations for house and bungalow floors among other structural elements like beams and columns.

### **5.2.2 For Further Study**

- 1) Other physical properties of crushed ceramic and porcelain powder such as fineness, specific surface, soundness, and density among others may be further

studied because they are of great significance in characterizing the behaviour of such materials.

- 2) In addition, mechanical and thermal properties of ceramic and porcelain clay tile powders should also be investigated in order to get in depth understanding on their strength properties as well as their mechanism of heat transfer.
- 3) Flexural behaviour of ceramic and porcelain concrete should be determined so as to develop empirical relationships between compressive, tensile and flexural strengths of concrete made using ceramic and porcelain powders.
- 4) The durability aspect of ceramic and porcelain concrete may also be studied This will guide in design especially when determining exposure conditions to choose appropriate cover to reinforcement of structural concrete obtained using ceramic and porcelain powders as partial cement substitutes.

### **5.3 Achievements**

The results of this study were published in peer review journals. These articles are attached in Appendix E. The two articles which were prepared and published include the following;

- (1) Oleng M., Kanali C., Gariy Z.C.A., & Ronoh E. (2018). Physical and Chemical Properties of Crushed Ceramic and Porcelain Clay Tile Powder. International Journal of IT, Engineering and Applied Sciences Research (IJIEASR). Volume 7, No. 7, July 2018. <http://www.ijrcjournals.org>.
- (2) Oleng M., Kanali C., Gariy Z.C.A., & Ronoh E. (2018). Physical and Mechanical Experimental Investigation of Concrete incorporated with Ceramic and Porcelain Clay Tile Powders as Partial Cement Substitutes. International

Journal of Engineering Research & Technology (IJERT). Vol. 7 Issue 09,  
September-2018. <http://www.ijert.org>.

- (3) Consideration for future publication: The cost benefit of using ceramic and porcelain clay tile powders as partial replacement of cement in concrete.

## REFERENCES

- ACI COMMITTEE 211.1-81, (2007). Standard practice for selecting proportions of normal, heavyweight and mass concrete. ACI manual of concrete practice.
- Agbede, O. I., & Monash, J. (2009). Suitability of Periwinkle Shell as Partial Replacement for Gravel in Concrete. Leonardo Electronic J. of Practice and Technologies, (15), 56-66.
- Ajileye, F. V. (2012). Investigations on Silica Fume as Partial Cement Replacement in Concrete, Global J. research in engineering. Civil and Structural, 12(1), 17-23.
- Al-Chaar, M. A., Ghassan, K., & Panagiotis G. A. (2013). Natural Pozzolan as a Partial Substitute for Cement in Concrete, The Open Construction and Building Technology Journal, 7, 33-42.
- Amudhavalli, N. K., & Jeena, M. (2012). Effect of silica fume on strength and durability parameters of concrete, Inter. J. Engineering Sciences & Emerging Tech., 3(1), 28-35.
- Arpad, H. (2004). Construction Materials and the Environment, Annu.Rev. Environ. Res., 29: 181-204.
- ASTM C 187 – 16, Standard Test Method for Amount of Water Required for Normal Consistency of Hydraulic Cement Paste. ASTM International, Pennsylvania.
- ASTM C 618. Standard Specification for Coal Fly Ash and Raw or Calcined Natural Pozzolan for Use in Concrete.
- ASTM C125. Standard Terminology Relating to Concrete and Concrete Aggregates.
- ASTM C188 – 17, Standard Test Method for Density of Hydraulic Cement. ASTM International, Pennsylvania



- Bakri, M. M., Hussin, K., Mohd, C., Baharin, S., Ramly, R., & Khairiatun, N. (2006). Concrete Ceramic Waste Slab (CCWS). *Journal of Engineering Research & Education*, vol. 3, pp. 139-145.
- Barrie, D. S., & Plaulson, B. C. (2002). *Professional Construction Management*, 3rd ed.; McGraw-Hill Inc. New York, NY, USA.
- Binici, H. (2007). Effect of crushed ceramic and basaltic pumice as fine aggregates on concrete mortar properties. *Construction and Building Materials*, vol. 21, no 6, pp. 1191- 1197. DOI: 10.1016/j.conbuildmat.2006.06.002.
- Bragança, S. R., & Bergmann, C. P. (2004). Traditional and glass powder porcelain: Technical and Microstructure analysis. *Journal of the European Ceramic Society* 24, pp 2383-2388.
- Brito, J. (2010). Abrasion resistance of concrete made with recycled aggregates. *International Journal of Sustainable Engineering*, vol. 3, no 1, pp. 58-64.
- BS 1881 Part 117 (2011). Testing concrete. Method for determination of tensile splitting strength. British Standards Institution, London, UK.
- BS 1881-101:2011. Testing concrete. Method of sampling fresh concrete on site, British Standard Institution, London, UK.
- BS 1881-102:2011. Testing concrete. Method for determination of slump, British Standard Institution, London, UK.
- BS 1881-115:2011. Testing concrete. Specification for compression testing machines for concrete, British Standard Institution, London, UK.
- BS 882 (1992), Specification for aggregates from natural sources for concrete. British Standards Institution, London, UK.

- BS 882 (1992), Specification for aggregates from natural sources for concrete. British Standards Institution, London, UK.
- BS EN 1008:2002. Mixing water for concrete — Specification for sampling, testing and assessing the suitability of water, including water recovered from processes in the concrete industry, as mixing water for concrete, British Standards Institution, London, UK.
- BS EN 1097-6:2013. Tests for mechanical and physical properties of aggregates. Part 6: Determination of particle density and water absorption. British Standard Institution, London, UK.
- BS EN 12350-2:2009. Testing fresh concrete. Part 2: Slump-test. British Standard Institution, London, UK.
- BS EN 12390-2:2009. Testing hardened Concrete. Part 2: Making and curing specimens for strength tests. British Standard Institution, London, UK.
- BS EN 197-1:2000, Cement - Part 1: Composition, specifications and conformity criteria for common cements, British Standard Institution, London, UK.
- BS EN 197-1:2000, Cement - Part 1: Composition, specifications and conformity criteria for common cements, British Standard Institution, London, UK.
- BS EN 197-3, (2016), Method of testing cement: Determination of setting time and soundness. British Standard Institution, London, UK.
- BS EN 933-1:2012. Tests for geometrical properties of aggregates. Part 1: Determination of particle size distribution — Sieving method. British Standard Institution, London, UK.

- BS EN 933-2:1996. Tests for geometrical properties of aggregates — Determination of particle size distribution — Test sieves, nominal size of apertures, British Standard Institution, London, UK.
- BS EN 933-2:1996. Tests for geometrical properties of aggregates — Determination of particle size distribution — Test sieves, nominal size of apertures, British Standard Institution, London, UK.
- Buchanan, J. A., & Olupot, P. W. (2006). Characterization of Ceramic Raw Minerals in Uganda for Production of Electrical Porcelain Insulators. *Proceedings from the International Conference on Advances in Engineering and Technology*.
- Bungey, J. H., & Millard, S. G. (1995). *The Testing of Concrete in Structures*, 3<sup>rd</sup> edition. Chapman & Hall, London.
- Cachim, P. B. (2009). Mechanical properties of brick aggregate concrete. *Construction and Building Materials*, vol. 23, no 3 pp. 1292-1297.
- Capros, P., Kouvaritakis, N., & Mantzos, L. (2001). Economic Evaluation of Sectoral Emission Reduction Objectives for Climate Change: Top-down Analysis of Greenhouse Gas Emission Possibilities in the EU.
- CESMM 3: 1991. Civil engineering standard Method of Measurement. Third edition. Thomas Telford, London.
- Chanakya, A. (2009). *Design of Structural Elements*, Third Edition. Taylor & Francis 2 Park Square, Milton Park, Abingdon, Oxon OX14 4RN.
- Chee, C. B., & Mahyuddin, R. (2011). The implementation of wood waste ash as a partial cement replacement material in the production of structural grade concrete and mortar. School of Housing, Building and Planning, Universiti Sains Malaysia, 11800 Penang, Malaysia.

- CIF. (2003). Cement Industry Environment Report. Cement Industry Federation.
- Correia, J. R., de Brito, J., Pereira, A. S. (2006). Effects on concrete durability of using recycled ceramic aggregates. *Materials and Structures*, vol. 39, no 2, pp. 169-177.
- El-Reedy., M. A. (2009). *Advanced materials and Techniques for reinforced Concrete Structures*. CRC Press, Taylor& Francis Group.
- Eurocode 2: Design of concrete structures - Part 1-1: General rules and rules for buildings. British Standard Institution, London, UK.
- Gartner, E. (2004). Industrially interesting approaches to “low-CO<sub>2</sub>” cements. *Cement and Concrete Research* 34, 1489–1498.
- Geem, M. G., & Marceau, M. L. (2002). *Using Concrete to Maximize LEED Points*, Concrete International.
- Genesan, S. (2000). *Employment, Technology and Construction Development*, Ashgate Publishing Company, Aldershot.
- GIBB. (2014). *Environment and Social Impact Assessment for Northern Collector Phase I*.
- Gomes, M., & de Brito, J. (2009). Structural concrete with incorporation of coarse recycled concrete and ceramic aggregates: durability performance. *Materials and Structures*, vol. 42 (2009), no 5, pp. 663-675.
- Guerra, I., Vivar, I., Llamas, B., Juan, A., & Moran, J. M. (2009). Eco-efficient concretes: The effects of using recycled ceramic material from sanitary installations on the mechanical properties of concrete. *Waste Management*, vol. 29, no 2, pp. 643-646.

- Hardil, P., & Arora, N. K. (2015). Use of ceramic waste powder in cement concrete. *International Journal for Innovative Research in Science and Technology*, 2(1).
- Hemanth, K. C., Ananda, R. K., Sateesh, B. K., Guraviaiah, T., Naveen, R. K., & Jami, S. (2015). Effect of waste ceramic tiles as partial replacement of coarse and fine aggregate of concrete. *International Advanced Research Journal in Science, Engineering and Technology*, 2(5), pp. 13-16.
- Holm, F. H. (1998). Ad Hoc Committee on Sustainable Building. Norwegian Building Research Institute, Blindern.
- Ikponmwosa, E. E., & Ehikhuenmen. (2017). The effect of ceramic waste as coarse aggregate on strength properties of concrete. *Nigerian Journal of Technology*, 36(3), pp. 691-696.
- Josa, A., Aguado, A., Cardim, A., & Byars, E. (2007). Comparative analysis of the life cycle impact assessment of available cement inventories in the EU. *Cement and Concrete Research* 37, 781–788.
- Josa, A., Aguado, A., Heino, A., Byars, E., & Cardim, A. (2004). Comparative analysis of available life cycle inventories of cement in the EU. *Cement and Concrete Research* 34, 1313–1320.
- Juan, A., Medina, C., Guerra, M. I., Llamas, B., Moran, J. Ma., & Tascon, A. (2010). Re-use of construction and demolition residues and industrial wastes for the elaboration or recycled eco-efficient concretes. *Spanish Journal of Agricultural Research*, vol. 8 (2010), no 1, pp. 25-34.
- Ken W. D. (2006). *Concrete Mix Design, Quality Control and Specification*, Third Edition published by Taylor & Francis, 2 Park Square, Milton Park, Abingdon, Oxon OX14 4RN.

- Kenface, E. (2016). Environmental and Social Impact Assessment Study Report for the Proposed High Grand Falls Multi-Purpose Dam Project.
- Kim, K. H., & Kang, K. I. (2004). Comparing Accuracy of Prediction Cost Estimation Using Case-Based Reasoning and Neural Networks. *Archit. Inst. Korea*, 20, 93–105.
- Kothari, C. R. (2004). *Research methodology: Methods and techniques*. New Age International (P) Ltd., Publishers Published by New Age International (P) Ltd., Publishers
- Koyuncu, H., Guney, Y., Yilmaz, G., Koyuncu, S., & Bakis, R. (2004). Utilization of ceramic wastes in the construction sector. *Key Engineering Materials*, vol. 264-268, pp. 2509-2512. DOI: 10.4028/www.scientific.net/KEM.264-268.2509.
- Kumar, J. P., Zala, L. B., & Umrigar, F. S. (2012). Experimental investigations on partial replacement of cement with fly ash in design mix concrete, *Inter. J. of Advanced Engineering Tech.*, 3(4), 126-129.
- Lafarge, (2007). *Lafarge in Kenya and Uganda: a sustainable commitment*. Press kit.
- Li, Z., (2011). *Advanced Concrete Technology - Li* - Wiley Online Library. Published by John Wiley & Sons., Inc, Hoboken, New Jersey, USA.
- Lopez G. F., Lopez C. C., Serrano L. M. A., Garcia, T. E., & Lopez M. A. (2011). Assessment of properties of recycled concrete by means of a highly fractioned factorial design of experiment. *Construction and Building Materials* 25 (10): 3802–3809.
- Lopez, V., Llamas, B., Juan, A., Moran. J. M., & Guerra, M. I., (2007). Eco-efficient concretes: Impact of the use of white ceramic powder on the mechanical properties of concrete. *Biosystems Engineering*, vol. 96, no 4, pp. 559-564.

- Mageswari, M., & Vidivelli, B. (2009). Innovative concrete using fly ash and waste sheet glass, *J. of Environ. Res. Develop.* 4(2), 476-483.
- Meena, A. V. J., (2017). Experimental Study of Ceramic Waste Electric Insulator Powder Used as a Partial Replacement of Cement in Concrete. *Journal of Materials Science & Surface Engineering*, 5(4): 606-611.
- Mosley, W. H., Hulse, R., & Bungey, J. H. (1996). *Reinforced Concrete Design to Eurocode 2*. Macmillan, Basingstoke.
- Muhwezi, L., Chamuriho, L. M. & Lema, N. M. (2012). An investigation into Materials Wastes on Building Construction Projects in Kampala-Uganda. *Journal of Engineering Research* Vol. 1(1), pp. 11-18.
- Naik, T. R., & Klaus, R. N. (2003). Wood Ash; A New Source of Pozzolanic Material. *Concrete International*. 20.
- Neville, A. M., (1995). *Properties of concrete*. Harlow, Essex: Longman.
- Newman, J., & Choo. B. S. (2003). *Advanced Concrete Technology*. Linacre House, Jordan Hill, Oxford.
- Nibudey, R. N., Nagarnaik, P. B., Parbat, D. K., Pande, A. M., & Polytechnic, G. (2014). Compressive Strength and Sorptivity Properties of PET Fiber Reinforced Concrete, 7(4), 1206–1216.
- Odero, T. J. (2015). Study on the feasibility of using Sawdust as partial replacement for Sand in concrete. University of Nairobi. (Master's thesis report)
- Ogola, P. F. A. (2009). Environmental Impact Assessment General Procedures. In *UNU-GTP* (pp. 1–16).
- Olupot, P. W. (2006). Assessment of ceramic raw materials in Uganda for electrical porcelain. (Doctoral dissertation, KTH).

- Pacheco, F., & Jalali, S. (2010). Reusing ceramic wastes in concrete. *Construction and Building Materials*, Volume 48, 2013, pp. 295-305.
- Pérez, J. M., Rincón, J. M., & Romero, M. (2012). Effect of moulding pressure on microstructure and technological properties of porcelain stoneware. *Ceramics International*, 38(1), 317-325.
- Prabagar, S., Kalya, S., & Kerthi, W. R. F. (2015). Wood ash as an effective raw material for concrete blocks. *International journal of research in engineering and technology*, Environmental Technology Section, Industrial Technology Institute, 363, Bauddhaloka Mawathe, colombo.
- Pradhan, D., & Dutta, D. (2013). Influence of Silica Fume on Normal Concrete, *Int. J. of Engineering Res. and Application*, 3(5), 79- 82.
- Puertas, F., Garcia-Diaz, I., Barba, A., Gazulla, M. F., Palacios, M., Gomez, M. P., & Martinez, R. S. (2008). Ceramic wastes as alternative raw materials for Portland cement clinker production. *Cement and Concrete Composites*, vol. 30 (2008), no 9, pp. 798-805.
- Raval, A. D. (2013). Ceramic Waste: Effective Replacement of Cement for Establishing Sustainable Concrete. *International Journal of Engineering Trends and Technology (IJETT) – Volume 4 Issue 6- June 2013*.
- Raval, A. D., Indrajit, N., Patel, Pitroda, J. (2013). Ceramic Waste: Effective Replacement of Cement for Establishing Sustainable Concrete, *Inter. J. Engineering Trends and Tech. (IJETT)*, 4(6), 2324-2329.
- Reddy, M. V. and Reddy, C. N. V. S. (2007). An experimental study on use of Rock Flour and insulator ceramic scrap in concrete. *Journal of Institution of Engineers, India*, 88, pp. 47-50.



- Saswat, H., & Vikas, S. (2016). Comprehensive Literature review on partial replacement of fine aggregate with ceramic and demolition waste in rigid pavement. *International Journal of Innovative Research in Science Engineering and Technology*, 5(8).
- Senthamarai, R. M., & Manoharan, D. P. (2005). Concrete with ceramic waste aggregate. *Cement & Concrete Composites*, vol. 27, no 9-10, pp. 910-913.
- Shruti, H. G., Gowtham, P. M. E., Samreen, T., & Syed, R. P. (2016). Reuse of ceramic waste as aggregate in concrete, *International Research Journal of Engineering and Technology*, 3(7), pp. 115-119.
- Siddesha, H. (2011). Experimental Studies on the Effect of Ceramic fine aggregate on the Strength properties of Concrete. *International Journal of Advances in Engineering, Science and Technology*.
- Silva, J., de Brito, J., & Veiga, R. (2010). Recycled red – clay ceramic construction and demolition waste for mortars production. *Journal of Materials in Civil Engineering*, vol. 22, no. 3, pp. 236-244.
- Sivaprakash, G., Saravana, K., & Lakhi, J. S. (2016). Experimental study on partial replacement of sand by ceramic waste in concrete. *Int. J. Chem.*
- Stathis, G., Ekonomakou, A., & Stournaras, C. J. (2004). Effect of firing conditions, filler grain size and quartz content on bending strength and physical properties of sanitary ware porcelain. *Journal of the European Ceramic*.
- Sudarsana, G. V. (2013). Influence of Water Absorption of the Ceramic Aggregate on Strength Properties of Ceramic Aggregate Concrete. *International Journal of Innovative Research in Science, Engineering and Technology*, Vol. 2.

- Tae, H. K. (2016). Assessment of Construction Cost Saving by Concrete Mixing the Activator Material. Building and Urban Research Institute, Korea Institute of Civil Engineering and Building Technology, Daehwa-dong 283, Goyandae-Ro, Ilsanseo-Gu, Goyang-Si, Gyeonggi-Do 10223, Korea
- Topcu, I. B., & Canbaz, M. (2007). Utilization of crushed tile as aggregate in concrete. Iranian Journal of Science and Technology Transaction B-Engineering, vol. 31, no B5, pp. 561-565.
- Vidivelli, B., and Mageswari, M. (2010). Study on fly ash concrete using SEM analysis, J. of Environ. Res. Develop., 5(1), 46-52.
- Vijayakumar, G., Vishaliny, H., & Govindarajulu, D. (2013). Studies on Glass Powder as Partial Replacement of Cement in Concrete Production, Inter. J. of Emerging Tech. and Advan. Engineering, 3(2), 153-157.
- Wadel, G. (2009). Sustainability in industrialized architecture: Modular lightweight construction applied to housing. Doctoral Thesis, Polytechnic University of Catalonia-Department of Architectural Constructions.
- Xi, F., Davis, S. J., Ciais, P., Crawford-Brown, D., Guan, D., Pade, C., & Bing, L. (2016). Substantial global carbon uptake by cement carbonation. Nature Geoscience, 9(12), 880-883.
- Ye, Z. S. M., (2006). An investigation ascertaining the suitability of wood ash as a partial replacement of cement in concrete at various intervals of (0-25%). International Journal of Innovative Research in Science, Engineering and Technology.

## APPENDICES

### Appendix A: Concrete Mix Design Tables

Table A.0: Concrete trial mix proportions for test specimen

Percentage Cement Replacement (%)	Mass of constituents (kg)			
	Cement	Ceramic and Porcelain Powder	Fine Aggregates	Coarse aggregates
0	1.850	0	4.271	5.283
5	1.758	0.092	4.271	5.283
10	1.665	0.185	4.271	5.283
15	1.572	0.278	4.271	5.283
20	1.480	0.370	4.271	5.283
25	1.388	0.462	4.271	5.283
30	1.295	0.555	4.271	5.283

The values in Table A.1 were obtained by following the ACI procedure of concrete mix design. In this procedure, the following Tables are used.

Table A.1: Workability, slump, and compacting factor of concretes with 19 or 38mm  
maximum size of aggregate

Degree of Workability	Slump		Compacting Factor	Use for which Concrete is Suitable
	(mm)	(in.)		
Very Low	0-25	0-1	0.78	Roads vibrated by power-operated machines. At the more workable end of this group, concrete may be compacted in certain cases with hand-operated machines.
Low	25-50	1-2	0.85	Roads vibrated by hand-operated machines. At the more workable end of

				this group, concrete may be manually compacted in roads using aggregate of rounded or irregular shape. Mass concrete foundations without vibrated or lightly reinforced sections with vibration.
Medium	25-100	2-4	0.92	At the less workable end of this group, manually compacted flat slabs using crushed aggregate. Normal reinforced concrete manually compacted and heavily reinforced sections with vibration.
High	100-175	4-7	0.95	For sections with congested reinforcement. Not normally suitable for vibration.

Source: (Building Research Establishment, Crown copyright).

Table A.2: Recommended values of slump for various types of construction

Type of Construction	Range of Slump	
	(mm)	(in.)
Reinforced foundation walls and footings	20-80	1-3
Plain footings, caissons and substructure walls	20-80	1-3
Beams and reinforced walls	20-100	1-4
Building columns	20-100	1-4
Pavements and slabs	20-80	1-3
Mass concrete	20-80	1-3

Source: (ACI 211.1-81)

Table A.3: Approximate requirement for mixing water and air content for different workabilities and nominal maximum sizes of aggregates

Workability or Air Content	Water Content (kg/m <sup>3</sup> ) of Concrete for Indicated Maximum Aggregate Size in mm							
	10	12.5	20	25	40	50	70	150
Non-air-entrained concrete								
Slump								
30–50 mm	205	200	185	180	160	155	145	125
80–100 mm	225	215	200	195	175	170	160	140
150–180 mm	240	230	210	205	185	180	170	—
Approximate entrapped air content (%)	3	2.5	2	1.5	1	0.5	0.3	0.2
Air-entrained concrete								
Slump								
30–50 mm	180	175	165	160	145	140	135	120
80–100 mm	200	190	180	175	160	155	150	135
150–180 mm	215	205	190	185	170	165	135	—
Recommended average total air content (%)								
Mild exposure	4.5	4.0	3.5	3.0	2.5	2.0	1.5 <sup>a</sup>	1.0 <sup>a</sup>
Moderate exposure	6.0	5.5	5.0	4.5	4.5	4.0	3.5 <sup>a</sup>	3.0 <sup>a</sup>
Extreme exposure <sup>b</sup>	7.5	7.0	6.0	6.0	5.5	5.0	4.5 <sup>a</sup>	4.0 <sup>a</sup>

Source: (ACI 211.1-81)

Table A.4: Relation between w/c and average compressive strength of concrete

Average Compressive Strength at 28 Days (MPa)	Effective Water/Cement Ratio (by Mass)	
	Non-Air-Entrained Concrete	Air-Entrained Concrete
45	0.38	—
40	0.43	—
35	0.48	0.40
30	0.55	0.48
25	0.62	0.53
20	0.70	0.61
15	0.80	0.71

Source: (ACI 211.1-81)

Table A.5: Dry bulk volume of coarse aggregate per unit volume of concrete.

Maximum Size of Aggregate (mm)	Dry Bulk Volume of Rodded Coarse Aggregate Per Unit Volume of Concrete for Different Fineness Modulus of Sand			
	2.40	2.60	2.80	3.00
10	0.50	0.48	0.46	0.44
12.5	0.59	0.57	0.55	0.53
20	0.66	0.64	0.62	0.60
25	0.71	0.69	0.67	0.65
40	0.75	0.73	0.71	0.69
50	0.78	0.76	0.74	0.72
70	0.82	0.80	0.78	0.76
150	0.87	0.85	0.83	0.81

Source: (ACI 211.1-81)

**Appendix B: Laboratory Test Certificates**

**Appendix B1: Chemical composition of ceramic powder**

REPUBLIC OF KENYA



MINISTRY OF PETROLEUM AND MINING  
STATE DEPARTMENT OF MINING

e-mail:cg@mining.go.ke  
When replying please quote ref No & date  
Ref. No.ORIGINAL CERT NO.2278/18

MACHAKOS ROAD  
P.O. Box 30009-00100 GPO  
NAIROBI  
Date...28<sup>th</sup> May, 2018

ASSAY CERTIFICATE

SENDER'S NAME : OLENG MORRIS  
DATE : 28.05.2018  
SAMPLE TYPE : CERAMIC  
SAMPLE NO : 2278/18

**RESULT**  
The sample was analyzed by XRF and found to have the following chemical composition.

**CHEMICAL COMPOSITION:**

Silica as SiO <sub>2</sub> .....	66.39%
Aluminium as Al <sub>2</sub> O <sub>3</sub> .....	18.14%
Iron as Fe.....	3.79%
Calcium as CaO .....	3.64%
Magnesium as MgO.....	3.60%
Potassium as K <sub>2</sub> O.....	3.39%
Titanium as Ti .....	0.37%
Zirconium as Zr .....	0.158%
Phosphorus as P <sub>2</sub> O <sub>5</sub> .....	0.144%
Zinc as Zn.....	0.104%
Manganese as Mn .....	0.038%
Chlorine as Cl .....	0.049%

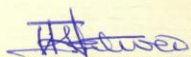
  
JORAM W. KATWEO  
FOR: DIRECTOR OF GEOLOGICAL SURVEYS.  
The results are based on test sample only.

FOR DIRECTOR OF  
GEOLOGICAL SURVEY  
28 MAY 2018  
P. O. Box 30009-00100  
NAIROBI

## Appendix B2: Chemical composition of porcelain powder

**REPUBLIC OF KENYA**



**MINISTRY OF PETROLEUM AND MINING**  
**STATE DEPARTMENT OF MINING**

e-mail:cg@mining.go.ke  
When replying please quote ref No & date  
Ref. No.ORIGINAL CERT NO.2279/18

MACHAKOS ROAD  
P.O. Box 30009-00100 GPO  
NAIROBI  
Date...28<sup>th</sup> May, 2018

**ASSAY CERTIFICATE**

**SENDER'S NAME : OLENG MORRIS**  
**DATE : 28.05.2018**  
**SAMPLE TYPE : PORCELAIN**  
**SAMPLE NO : 2279/18**

**RESULT**  
The sample was analyzed by XRF and found to have the following chemical composition.

**CHEMICAL COMPOSITION:**

Silica as SiO <sub>2</sub> .....	73.04%
Aluminium as Al <sub>2</sub> O <sub>3</sub> .....	19.39%
Potassium as K <sub>2</sub> O.....	2.558%
Magnesium as MgO.....	1.582%
Chlorine as Cl .....	0.155%
Iron as Fe.....	1.418%
Calcium as CaO .....	1.432%
Titanium as Ti .....	0.226%
Manganese as Mn .....	0.037%
Zirconium as Zr .....	0.027%
Zinc as Zn.....	0.104%

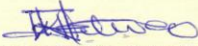
  
**JORAM W. KATWEO**  
**FOR: DIRECTOR OF GEOLOGICAL SURVEYS**

**FOR DIRECTOR OF  
GEOLOGICAL SURVEYS**  
**28 MAY 2018**  
P. O. Box 30009-00100  
NAIROBI

The results are based on test sample only.



## Appendix B3: Characterisation of coarse aggregates

*Excellence Through Precision & Integrity*



Uganda  
Rwanda  
Tanzania

### CERTIFICATE OF ANALYSIS

1. Project: SUITABILITY OF CRUSHED CERAMIC AND PORCELAIN CLAY TILES AS PARTIAL REPLACEMENT OF CEMENT IN CONCRETE

2. Client: STUDENT RESEARCH

3. Samples Description: COARSE AGGREGATES

4. Date Delivered: Not Specified

5. Nature of test: Sieve Analysis, Water Absorption, Bulk Density, and Specific Gravity

6. Test Method: BS 812:1989, BS 882: 1992

7. Sample Ref. 2018/S075

8. Results:

Date: 2/3/2018

**Summary of Laboratory Test Results**

Sample Source	Sample Test Identification	Sieve Analysis % passing given sieve						Specific Gravity	Water absorption (%)	Bulk Density (g/cm <sup>3</sup> )
		50.0mm	37.5 mm	20.0 mm	14 mm	10.0 mm	5.0 mm			
Not Specified	20mm Single Size Aggregates	100	100.00	65.17	5.01	0.12	0.09	2.7	1.1	1.5

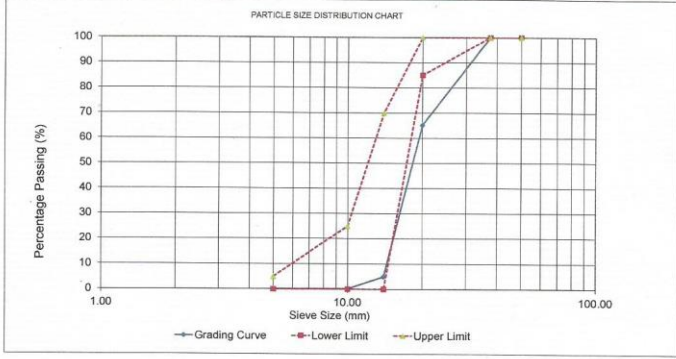

PARTICLE SIZE DISTRIBUTION CHART

**9. Remarks**

9.1 This report relates only to the samples tested.

9.2 All tested samples will be immediately discarded after receipt of results by the client

Checked by 

Arthur Mutabazi  
Materials Engineer  
Teclab Ltd

Approved by 

Alex Ssenyondo Mulira  
Technical Manager  
Teclab Ltd

Plot 15 Mapera Road | Nalukolongo Industrial Area  
P.O.Box 24934 Kampala | Uganda | Tel: +256 392 175 246 | Fax +256 414 345149  
web: www.teclabafrika.com | email: teclab@teclabafrika.com

## Appendix B4: Characterisation of fine aggregates (sand)

*Excellence Through Precision & Integrity*



Uganda  
Rwanda  
Tanzania

### CERTIFICATE OF ANALYSIS

Date: 2/3/2018

1. Project: SUITABILITY OF CRUSHED CERAMIC AND PORCELAIN CLAY TILES AS PARTIAL REPLACEMENT OF CEMENT IN CONCRETE
2. Client: STUDENT RESEARCH
3. Samples Description: Sand
4. Date Delivered: Not Specified
5. Nature of test: Sieve Analysis, Moisture Content, Specific Gravity and Silt Content
6. Test Method: BS 882:1992
7. Sample Ref. No. 2018/S075
8. Results:
 

Sample Test Identification	Sieve Analysis % passing given sieve									Moisture Content (%)	Specific Gravity (Mg/m <sup>3</sup> )	Silt Content (%)
	37.5 mm	20.0 mm	10.0 mm	5.0 mm	2.0 mm	1.18 mm	0.60 mm	0.30 mm	0.15 mm			
Limits (Upper - Lower)	100	100	100	100 - 89	100 - 60	100 - 30	100 - 15	70 - 5	15 - 0			
SAND	100.0	100.0	99.2	91.0	73.9	58.1	20.3	6.4	1.7	4.4	2.6	1.5



9. Remarks  
 9.1 This report relates only to the samples tested.  
 9.2 All tested samples will be immediately discarded after receipt of results by the client

Checked by: 

Athur Mutabazi  
Materials Engineer  
Teclab Ltd

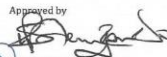
Approved by: 

Alex Saenyondo Mulira  
Technical Manager  
Teclab Ltd



**TECLAB LIMITED**  
THE ENGINEERS LABORATORY  
P. O. BOX 24934, KAMPALA

---

Plot 15 Mapera Road | Nalukolongo Industrial Area  
 | P.O.Box 24934 Kampala | Uganda | Tel: +256 392 175 246 | Fax +256 414 345149  
 web: www.teclabafrika.com | email: teclab@teclabafrika.com

## Appendix B5: Compressive strength of concrete for various cement replacement levels at different ages

 Uganda  
Rwanda  
Tanzania

*Excellence Through Precision & Integrity*

### CERTIFICATE OF ANALYSIS FOR CONCRETE

TL-TI-FORM-27 Version 2 Date: 08-05-2018

1. **Samples :**

1.1 **Sample Description :**  
Concrete cube samples were delivered to this laboratory and tested.

2. **Nature of test :** Compressive Strength Test

3. **Test Method :** BS 1881 : Part 116 : 1983

4. **Results :**

**TEST RESULTS FOR CONCRETE CUBES**

<b>Project:</b>		Suitability of crushed ceramic and porcelain clay tiles as partial replacement of cement in concrete					
<b>Client:</b>		Student Research			<b>Method of Compaction:</b>		Hand Tamping
<b>Curing Period:</b>	7 Days	<b>Testing Age:</b>	7 Days	<b>Technician:</b>		Alice	
<b>Concrete Class</b>	C25	<b>Design Strength</b>			25MPa		
<b>Treatment (%)</b>	0	<b>Slump</b>			60		

DATE OF CAST	DATE TESTED	SAMPLE NUMBER	AREA OF USE	DIMENSIONS (mm)	WEIGHT (Kg)	DENSITY (Kg/m <sup>3</sup> )	CRUSHING LOAD (kN)	ULTIMATE COMPRESSIVE STRENGTH (N/mm <sup>2</sup> )
26/03/2018	02/04/2018	1	Mass concrete and reinforced concrete	150*150*150	8.30	2459	586.5	26.07
		2			8.49	2516	574.2	25.52
<b>Average Compressive Strength</b>								<b>25.8</b>

5. **Remarks:**

5.1 This report relates only to the samples tested.

5.2 All tested samples will be immediately discarded after receipt of results by the client

Checked by:   
Wangoda Vitalis  
Materials Engineer  
Teclab Limited

Client's representative :



Page 1 of 1

---

Plot 15 Mapera Road | Nalukolongo Industrial Area  
P.O.Box 24934 Kampala | Uganda | Tel: +256 392 175 246 | Fax +256 414 345149  
web: www.teclabfrica.com | email: teclab@teclabfrica.com

## CERTIFICATE OF ANALYSIS FOR CONCRETE

TL-TI-FORM-27 Version 2

Date: 08-05-2018

1. **Samples :**

1.1 **Sample Description :**

Concrete cube samples were delivered to this laboratory and tested.

2. **Nature of test :** Compressive Strength Test

3. **Test Method :** BS 1881 : Part 116 : 1983

4. **Results :**

### TEST RESULTS FOR CONCRETE CUBES

<b>Project:</b>	Suitability of crushed ceramic and porcelain clay tiles as partial replacement of cement in concrete									
<b>Client:</b>	Student Research				<b>Method of Compaction:</b>	Hand Tamping				
<b>Curing Period:</b>	7 Days	<b>Testing Age:</b>	7 Days		<b>Technician:</b>	Alice				
<b>Concrete Class</b>	C25				<b>Design Strength</b>	25MPa				
<b>Treatment (%)</b>	5				<b>Slump</b>	58				
<b>DATE OF CAST</b>	<b>DATE TESTED</b>	<b>SAMPLE NUMBER</b>	<b>AREA OF USE</b>	<b>DIMENSIONS (mm)</b>	<b>WEIGHT (Kg)</b>	<b>DENSITY (Kg/m<sup>3</sup>)</b>	<b>CRUSHING LOAD (kN)</b>	<b>ULTIMATE COMPRESSIVE STRENGTH (N/mm<sup>2</sup>)</b>		
29/03/2018	5/04/2018	1	Mass concrete and reinforced concrete	150*150*150	8.49	2516	611.9	27.20		
		2			8.39	2486	609.8	27.10		
<b>Average Compressive Strength</b>								<b>27.1</b>		

5. **Remarks:**

- 5.1 This report relates only to the samples tested.  
5.2 All tested samples will be immediately discarded after receipt of results by the client

Checked by:

Wangoda Vitalis  
Materials Engineer  
Teclab Limited



Client's representative:

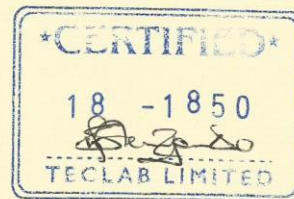

Page 1 of 1

## CERTIFICATE OF ANALYSIS FOR CONCRETE

TL-TI-FORM-27 Version 2

Date: 08-05-2018

1. **Samples :**
- 1.1 **Sample Description :**  
Concrete cube samples were delivered to this laboratory and tested.
2. **Nature of test :** Compressive Strength Test
3. **Test Method :** BS 1881 : Part 116 : 1983
4. **Results :**

### TEST RESULTS FOR CONCRETE CUBES

<b>Project:</b>		Suitability of crushed ceramic and porcelain clay tiles as partial replacement of cement in concrete						
<b>Client:</b>		Student Research			<b>Method of Compaction:</b>		Hand Tamping	
<b>Curing Period:</b>		7 Days	<b>Testing Age:</b>		7 Days		<b>Technician:</b> Alice	
<b>Concrete Class</b>		C25			<b>Design Strength</b>		25MPa	
<b>Treatment (%)</b>		10			<b>Slump</b>		55	
DATE OF CAST	DATE TESTED	SAMPLE NUMBER	AREA OF USE	DIMENSIONS (mm)	WEIGHT (kg)	DENSITY (kg/m <sup>3</sup> )	CRUSHING LOAD (kN)	ULTIMATE COMPRESSIVE STRENGTH (N/mm <sup>2</sup> )
05/04/2018	12/04/2018	1	Mass concrete and reinforced concrete	150*150*150	8.60	2548	612.8	27.24
		2			8.54	2530	601.9	26.75
<b>Average Compressive Strength</b>								27.0

5. **Remarks:**
- 5.1 This report relates only to the samples tested.
- 5.2 All tested samples will be immediately discarded after receipt of results by the client

Checked by:

Wangoda Vitalis  
 Materials Engineer  
 Teclab Limited

Client's representative :

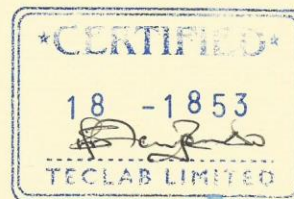

Page 1 of 1

### CERTIFICATE OF ANALYSIS FOR CONCRETE

TL-TI-FORM-27 Version 2

Date: 08-05-2018

1. Samples :
  - 1.1 Sample Description :  
Concrete cube samples were delivered to this laboratory and tested.
2. Nature of test : Compressive Strength Test
3. Test Method : BS 1881 : Part 116 : 1983
4. Results :

TEST RESULTS FOR CONCRETE CUBES

Project:		Suitability of crushed ceramic and porcelain clay tiles as partial replacement of cement in concrete						
Client:		Student Research			Method of Compaction:		Hand Tamping	
Curing Period:		7 Days	Testing Age:		7 Days	Technician:		Alice
Concrete Class		C25			Design Strength		25MPa	
Treatment (%)		15			Slump		50	
DATE OF CAST	DATE TESTED	SAMPLE NUMBER	AREA OF USE	DIMENSIONS (mm)	WEIGHT (Kg)	DENSITY (Kg/m <sup>3</sup> )	CRUSHING LOAD (kN)	ULTIMATE COMPRESSIVE STRENGTH (N/mm <sup>2</sup> )
06/04/2018	13/04/2018	1	Mass concrete and reinforced concrete	150*150*150	8.57	2539	506.7	22.52
		2			8.63	2557	499.7	22.21
Average Compressive Strength								22.4

5. Remarks:
  - 5.1 This report relates only to the samples tested.
  - 5.2 All tested samples will be immediately discarded after receipt of results by the client

Checked by:

Wangoda Vitalis  
Materials Engineer  
Teclab Limited

Client's representative :

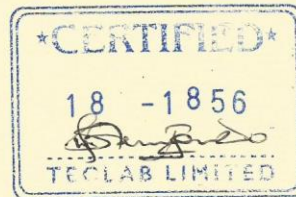

### CERTIFICATE OF ANALYSIS FOR CONCRETE

TL-TI-FORM-27 Version 2

Date: 08-05-2018

1. **Samples :**
- 1.1 **Sample Description :**  
Concrete cube samples were delivered to this laboratory and tested.
2. **Nature of test :** Compressive Strength Test
3. **Test Method :** BS 1881 : Part 116 : 1983
4. **Results :**

**TEST RESULTS FOR CONCRETE CUBES**

<b>Project:</b>	Suitability of crushed ceramic and porcelain clay tiles as partial replacement of cement in concrete							
<b>Client:</b>	Student Research			<b>Method of Compaction:</b>	Hand Tamping			
<b>Curing Period:</b>	7 Days	<b>Testing Age:</b>	7 Days	<b>Technician:</b>	Alice			
<b>Concrete Class</b>	C25			<b>Design Strength</b>	25MPa			
<b>Treatment (%)</b>	20			<b>Slump</b>	49			
<b>DATE OF CAST</b>	<b>DATE TESTED</b>	<b>SAMPLE NUMBER</b>	<b>AREA OF USE</b>	<b>DIMENSIONS (mm)</b>	<b>WEIGHT (Kg)</b>	<b>DENSITY (Kg/m<sup>3</sup>)</b>	<b>CRUSHING LOAD (kN)</b>	<b>ULTIMATE COMPRESSIVE STRENGTH (N/mm<sup>2</sup>)</b>
07/04/2018	14/05/2018	1	Mass concrete and reinforced concrete	150*150*150	8.26	2447	486.7	21.63
		2			8.48	2513	491.5	21.84
<b>Average Compressive Strength</b>								21.7

5. **Remarks:**
- 5.1 This report relates only to the samples tested.
- 5.2 All tested samples will be immediately discarded after receipt of results by the client

Checked by:

Wangoda Vitalis  
Materials Engineer  
Teclab Limited

Client's representative :



### CERTIFICATE OF ANALYSIS FOR CONCRETE

TL-TI-FORM-27 Version 2

Date: 08-05-2018

1. **Samples :**
- 1.1 Sample Description :  
Concrete cube samples were delivered to this laboratory and tested.
2. **Nature of test :** Compressive Strength Test
3. **Test Method :** BS 1881 : Part 116 : 1983
4. **Results :**

TEST RESULTS FOR CONCRETE CUBES

<b>Project:</b>	Suitability of crushed ceramic and porcelain clay tiles as partial replacement of cement in concrete							
<b>Client:</b>	Student Research				<b>Method of Compaction:</b>	Hand Tamping		
<b>Curing Period:</b>	7 Days	<b>Testing Age:</b>	7 Days	<b>Technician:</b>	Alice			
<b>Concrete Class</b>	C25			<b>Design Strength</b>	25MPa			
<b>Treatment (%)</b>	25			<b>Slump</b>	46			
<b>DATE OF CAST</b>	<b>DATE TESTED</b>	<b>SAMPLE NUMBER</b>	<b>AREA OF USE</b>	<b>DIMENSIONS (mm)</b>	<b>WEIGHT (Kg)</b>	<b>DENSITY (Kg/m<sup>3</sup>)</b>	<b>CRUSHING LOAD (kN)</b>	<b>ULTIMATE COMPRESSIVE STRENGTH (N/mm<sup>2</sup>)</b>
09/04/2018	16/04/2018	1	Mass concrete and reinforced concrete	150*150*150	8.41	2492	355.3	15.79
		2			8.45	2504	361.2	16.05
<b>Average Compressive Strength</b>								15.9

5. **Remarks:**
- 5.1 This report relates only to the samples tested.
- 5.2 All tested samples will be immediately discarded after receipt of results by the client

Checked by:

Wangoda Vitalis  
Materials Engineer  
Teclab Limited

Client's representative :





### CERTIFICATE OF ANALYSIS FOR CONCRETE

TL-TI-FORM-27 Version 2

Date: 08-05-2018

1. **Samples :**
  - 1.1 **Sample Description :**  
Concrete cube samples were delivered to this laboratory and tested.
2. **Nature of test :** Compressive Strength Test
3. **Test Method :** BS 1881 : Part 116 : 1983
4. **Results :**

**TEST RESULTS FOR CONCRETE CUBES**

<b>Project:</b>	Suitability of crushed ceramic and porcelain clay tiles as partial replacement of cement in concrete							
<b>Client:</b>	Student Research				<b>Method of Compaction:</b>	Hand Tamping		
<b>Curing Period:</b>	7 Days	<b>Testing Age:</b>	7 Days	<b>Technician:</b>	Alice			
<b>Concrete Class</b>	C25			<b>Design Strength</b>	25MPa			
<b>Treatment (%)</b>	30			<b>Slump</b>	44			
<b>DATE OF CAST</b>	<b>DATE TESTED</b>	<b>SAMPLE NUMBER</b>	<b>AREA OF USE</b>	<b>DIMENSIONS (mm)</b>	<b>WEIGHT (Kg)</b>	<b>DENSITY (Kg/m<sup>3</sup>)</b>	<b>CRUSHING LOAD (kN)</b>	<b>ULTIMATE COMPRESSIVE STRENGTH (N/mm<sup>2</sup>)</b>
10/04/2018	17/04/2018	1	Mass concrete and reinforced concrete	150*150*150	8.12	2406	311.5	13.84
		2			8.19	2427	302.1	13.43
<b>Average Compressive Strength</b>								13.6

5. **Remarks:**
  - 5.1 This report relates only to the samples tested.
  - 5.2 All tested samples will be immediately discarded after receipt of results by the client

Checked by:

Wangoda Vitalis  
Materials Engineer  
Teclab Limited

Client's representative :

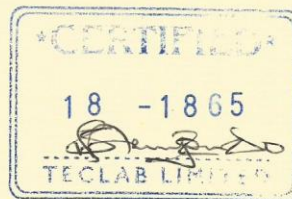

### CERTIFICATE OF ANALYSIS FOR CONCRETE

TL-TI-FORM-27 Version 2

Date: 08-05-2018

1. **Samples :**
- 1.1 **Sample Description :**  
Concrete cube samples were delivered to this laboratory and tested.
2. **Nature of test :** Compressive Strength Test
3. **Test Method :** BS 1881 : Part 116 : 1983
4. **Results :**

**TEST RESULTS FOR CONCRETE CUBES**

<b>Project:</b>	Suitability of crushed ceramic and porcelain clay tiles as partial replacement of cement in concrete							
<b>Client:</b>	Student Research				<b>Method of Compaction:</b>	Hand Tamping		
<b>Curing Period:</b>	14 Days	<b>Testing Age:</b>	14 Days	<b>Technician:</b>	Alice			
<b>Concrete Class</b>	C25			<b>Design Strength</b>	25MPa			
<b>Treatment (%)</b>	0			<b>Slump</b>	60			
<b>DATE OF CAST</b>	<b>DATE TESTED</b>	<b>SAMPLE NUMBER</b>	<b>AREA OF USE</b>	<b>DIMENSIONS (mm)</b>	<b>WEIGHT (Kg)</b>	<b>DENSITY (Kg/m<sup>3</sup>)</b>	<b>CRUSHING LOAD (kN)</b>	<b>ULTIMATE COMPRESSIVE STRENGTH (N/mm<sup>2</sup>)</b>
26/03/2018	9/04/2018	1	Mass concrete and reinforced concrete	150*150*150	8.46	2507	712.5	31.67
		2			8.49	2516	639.5	28.42
<b>Average Compressive Strength</b>								<b>30.0</b>

5. **Remarks:**
- 5.1 This report relates only to the samples tested.
- 5.2 All tested samples will be immediately discarded after receipt of results by the client

Checked by:

Wangoda Vitalis  
Materials Engineer  
Teclab Limited

Client's representative :

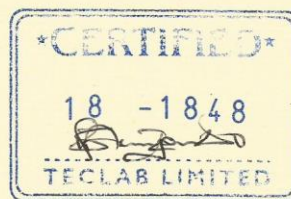

### CERTIFICATE OF ANALYSIS FOR CONCRETE

TL-TI-FORM-27 Version 2

Date: 08-05-2018

1. **Samples :**
  - 1.1 Sample Description :  
Concrete cube samples were delivered to this laboratory and tested.
2. **Nature of test :** Compressive Strength Test
3. **Test Method :** BS 1881 : Part 116 : 1983
4. **Results :**

**TEST RESULTS FOR CONCRETE CUBES**

<b>Project:</b>	Suitability of crushed ceramic and porcelain clay tiles as partial replacement of cement in concrete							
<b>Client:</b>	Student Research				<b>Method of Compaction:</b>	Hand Tamping		
<b>Curing Period:</b>	14 Days	<b>Testing Age:</b>	14 Days	<b>Technician:</b>	Alice			
<b>Concrete Class</b>	C25			<b>Design Strength</b>	25MPa			
<b>Treatment (%)</b>	5			<b>Slump</b>	58			
<b>DATE OF CAST</b>	<b>DATE TESTED</b>	<b>SAMPLE NUMBER</b>	<b>AREA OF USE</b>	<b>DIMENSIONS (mm)</b>	<b>WEIGHT (Kg)</b>	<b>DENSITY (Kg/m<sup>3</sup>)</b>	<b>CRUSHING LOAD (kN)</b>	<b>ULTIMATE COMPRESSIVE STRENGTH (N/mm<sup>2</sup>)</b>
29/03/2018	12/04/2018	1	Mass concrete and reinforced concrete	150*150*150	8.53	2527	753.5	33.49
		2			8.64	2560	755.5	33.58
<b>Average Compressive Strength</b>								33.5

5. **Remarks:**
  - 5.1 This report relates only to the samples tested.
  - 5.2 All tested samples will be immediately discarded after receipt of results by the client

Checked by:

Wangoda Vitalis  
Materials Engineer  
Teclab Limited

Client's representative :

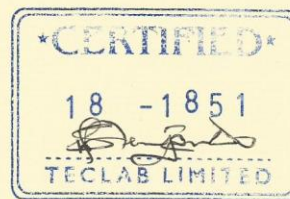

## CERTIFICATE OF ANALYSIS FOR CONCRETE

TL-TI-FORM-27 Version 2

Date: 08-05-2018

1. **Samples :**
- 1.1 Sample Description :  
Concrete cube samples were delivered to this laboratory and tested.
2. **Nature of test :** Compressive Strength Test
3. **Test Method :** BS 1881 : Part 116 : 1983
4. **Results :**

### TEST RESULTS FOR CONCRETE CUBES

<b>Project:</b>		Suitability of crushed ceramic and porcelain clay tiles as partial replacement of cement in concrete						
<b>Client:</b>		Student Research			<b>Method of Compaction:</b>		Hand Tamping	
<b>Curing Period:</b>		14 Days	<b>Testing Age:</b>		14 Days	<b>Technician:</b>		Alice
<b>Concrete Class</b>		C25			<b>Design Strength</b>		25MPa	
<b>Treatment (%)</b>		10			<b>Slump</b>		55	
DATE OF CAST	DATE TESTED	SAMPLE NUMBER	AREA OF USE	DIMENSIONS (mm)	WEIGHT (Kg)	DENSITY (Kg/m <sup>3</sup> )	CRUSHING LOAD (kN)	ULTIMATE COMPRESSIVE STRENGTH (N/mm <sup>2</sup> )
05/04/2018	19/04/2018	1	Mass concrete and reinforced concrete	150*150*150	8.66	2566	739.9	32.88
		2			8.85	2622	598.8	26.61
<b>Average Compressive Strength</b>								29.7

5. **Remarks:**
- 5.1 - This report relates only to the samples tested.
- 5.2 All tested samples will be immediately discarded after receipt of results by the client

Checked by:

  
 Wangoda Vitalis  
 Materials Engineer  
 Teclab Limited

Client's representative:



Page 1 of 1

## CERTIFICATE OF ANALYSIS FOR CONCRETE

TL-TI-FORM-27 Version 2

Date: 08-05-2018

1. **Samples :**
  - 1.1 Sample Description :  
Concrete cube samples were delivered to this laboratory and tested.
2. **Nature of test :** Compressive Strength Test
3. **Test Method :** BS 1881 : Part 116 : 1983
4. **Results :**

### TEST RESULTS FOR CONCRETE CUBES

<b>Project:</b>		Suitability of crushed ceramic and porcelain clay tiles as partial replacement of cement in concrete						
<b>Client:</b>		Student Research			<b>Method of Compaction:</b>		Hand Tamping	
<b>Curing Period:</b>		14 Days	<b>Testing Age:</b>	14 Days	<b>Technician:</b>		Alice	
<b>Concrete Class</b>		C25			<b>Design Strength</b>		25MPa	
<b>Treatment (%)</b>		15			<b>Slump</b>		50	
<b>DATE OF CAST</b>	<b>DATE TESTED</b>	<b>SAMPLE NUMBER</b>	<b>AREA OF USE</b>	<b>DIMENSIONS (mm)</b>	<b>WEIGHT (Kg)</b>	<b>DENSITY (Kg/m<sup>3</sup>)</b>	<b>CRUSHING LOAD (kN)</b>	<b>ULTIMATE COMPRESSIVE STRENGTH (N/mm<sup>2</sup>)</b>
06/04/2018	20/04/2018	1	Mass concrete and reinforced concrete	150*150*150	8.51	2521	547.4	24.33
		2			8.63	2557	567.0	25.20
<b>Average Compressive Strength</b>								24.8

5. **Remarks:**
  - 5.1 This report relates only to the samples tested.
  - 5.2 All tested samples will be immediately discarded after receipt of results by the client

Checked by:

Wangoda Vitalis  
Materials Engineer  
Teclab Limited



Client's representative :



Page 1 of 1

## CERTIFICATE OF ANALYSIS FOR CONCRETE

TL-TI-FORM-27 Version 2

Date: 08-05-2018

1. **Samples :**
- 1.1 Sample Description :  
Concrete cube samples were delivered to this laboratory and tested.
2. **Nature of test :** Compressive Strength Test
3. **Test Method :** BS 1881 : Part 116 : 1983
4. **Results :**

### TEST RESULTS FOR CONCRETE CUBES

<b>Project:</b>		Suitability of crushed ceramic and porcelain clay tiles as partial replacement of cement in concrete							
<b>Client:</b>		Student Research			<b>Method of Compaction:</b>		Hand Tamping		
<b>Curing Period:</b>		14 Days	<b>Testing Age:</b>		14 Days	<b>Technician:</b>		Alice	
<b>Concrete Class</b>		C25			<b>Design Strength</b>		25MPa		
<b>Treatment (%)</b>		20			<b>Slump</b>		49		
<b>DATE OF CAST</b>	<b>DATE TESTED</b>	<b>SAMPLE NUMBER</b>	<b>AREA OF USE</b>	<b>DIMENSIONS (mm)</b>	<b>WEIGHT (Kg)</b>	<b>DENSITY (Kg/m<sup>3</sup>)</b>	<b>CRUSHING LOAD (kN)</b>	<b>ULTIMATE COMPRESSIVE STRENGTH (N/mm<sup>2</sup>)</b>	
07/04/2018	21/04/2018	1	Mass concrete and reinforced concrete	150*150*150	8.45	2504	560.9	24.93	
		2			8.26	2447	536.8	23.86	
<b>Average Compressive Strength</b>								24.4	

5. **Remarks:**
- 5.1 This report relates only to the samples tested.
- 5.2 All tested samples will be immediately discarded after receipt of results by the client

Checked by:

Wangoda Vitalis  
Materials Engineer  
Teclab Limited



Client's representative :

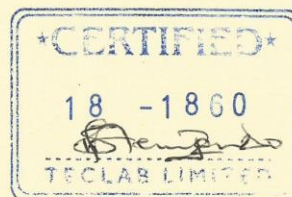

Page 1 of 1

## CERTIFICATE OF ANALYSIS FOR CONCRETE

TL-TI-FORM-27 Version 2

Date: 08-05-2018

1. **Samples :**
- 1.1 **Sample Description :**  
Concrete cube samples were delivered to this laboratory and tested.
2. **Nature of test :** Compressive Strength Test
3. **Test Method :** BS 1881 : Part 116 : 1983
4. **Results :**

### TEST RESULTS FOR CONCRETE CUBES

<b>Project:</b>		Suitability of crushed ceramic and porcelain clay tiles as partial replacement of cement in concrete							
<b>Client:</b>		Student Research				<b>Method of Compaction:</b>		Hand Tamping	
<b>Curing Period:</b>		14 Days		<b>Testing Age:</b>		14 Days		<b>Technician:</b> Alice	
<b>Concrete Class</b>		C25				<b>Design Strength</b>		25MPa	
<b>Treatment (%)</b>		25				<b>Slump</b>		46	
DATE OF CAST	DATE TESTED	SAMPLE NUMBER	AREA OF USE	DIMENSIONS (mm)	WEIGHT (Kg)	DENSITY (Kg/m <sup>3</sup> )	CRUSHING LOAD (kN)	ULTIMATE COMPRESSIVE STRENGTH (N/mm <sup>2</sup> )	
09/04/2018	23/04/2018	1	Mass concrete and reinforced concrete	150*150*150	8.34	2471	390.1	17.34	
		2			8.28	2453	368.1	16.36	
<b>Average Compressive Strength</b>								16.8	

5. **Remarks:**
- 5.1 This report relates only to the samples tested.
- 5.2 All tested samples will be immediately discarded after receipt of results by the client

Checked by:

Wangoda Vitalis  
Materials Engineer  
TecLab Limited



Client's representative :



Page 1 of 1

### CERTIFICATE OF ANALYSIS FOR CONCRETE

TL-TI-FORM-27 Version 2

Date: 08-05-2018

1. **Samples :**
- 1.1 **Sample Description :**  
Concrete cube samples were delivered to this laboratory and tested.
2. **Nature of test :** Compressive Strength Test
3. **Test Method :** BS 1881 : Part 116 : 1983
4. **Results :**

TEST RESULTS FOR CONCRETE CUBES

<b>Project:</b>	Suitability of crushed ceramic and porcelain clay tiles as partial replacement of cement in concrete		
<b>Client:</b>	Student Research	<b>Method of Compaction:</b>	Hand Tamping
<b>Curing Period:</b>	14 Days	<b>Testing Age:</b>	14 Days
<b>Concrete Class</b>	C25	<b>Design Strength</b>	25MPa
<b>Treatment (%)</b>	30	<b>Slump</b>	44
<b>Technician:</b>	Alice		

DATE OF CAST	DATE TESTED	SAMPLE NUMBER	AREA OF USE	DIMENSIONS (mm)	WEIGHT (Kg)	DENSITY (Kg/m <sup>3</sup> )	CRUSHING LOAD (kN)	ULTIMATE COMPRESSIVE STRENGTH (N/mm <sup>2</sup> )
10/04/2018	24/04/2018	1	Mass concrete and reinforced concrete	150*150*150	8.40	2489	390.0	17.33
		2			8.23	2439	389.7	17.32
<b>Average Compressive Strength</b>								17.3

5. **Remarks:**
- 5.1 This report relates only to the samples tested.
- 5.2 All tested samples will be immediately discarded after receipt of results by the client

Checked by:

Wangoda Vitalis  
Materials Engineer  
Teclab Limited

Client's representative :

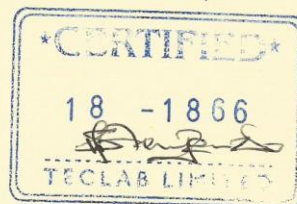



## CERTIFICATE OF ANALYSIS FOR CONCRETE

TL-TI-FORM-27 Version 2

Date: 08-05-2018

1. **Samples :**
- 1.1 Sample Description :  
Concrete cube samples were delivered to this laboratory and tested.
2. **Nature of test :** Compressive Strength Test
3. **Test Method :** BS 1881 : Part 116 : 1983
4. **Results :**

### TEST RESULTS FOR CONCRETE CUBES

<b>Project:</b>		Suitability of crushed ceramic and porcelain clay tiles as partial replacement of cement in concrete							
<b>Client:</b>		Student Research				<b>Method of Compaction:</b>		Hand Tamping	
<b>Curing Period:</b>		28 Days	<b>Testing Age:</b>		28 Days	<b>Technician:</b>		Alice	
<b>Concrete Class</b>		C25				<b>Design Strength</b>		25MPa	
<b>Treatment (%)</b>		0				<b>Slump</b>		60	
DATE OF CAST	DATE TESTED	SAMPLE NUMBER	AREA OF USE	DIMENSIONS (mm)	WEIGHT (Kg)	DENSITY (Kg/m <sup>3</sup> )	CRUSHING LOAD (kN)	ULTIMATE COMPRESSIVE STRENGTH (N/mm <sup>2</sup> )	
26/03/2018	23/04/2018	1	Mass concrete and reinforced concrete	150*150*150	8.52	2524	746.9	33.20	
		2			9.28	2750	752.8	33.46	
<b>Average Compressive Strength</b>								<b>33.3</b>	

5. **Remarks:**
- 5.1 This report relates only to the samples tested.
- 5.2 All tested samples will be immediately discarded after receipt of results by the client

Checked by:

  
 Wangoda Vitalis  
 Materials Engineer  
 Teclab Limited

Client's representative :

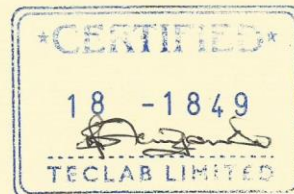

Page 1 of 1

### CERTIFICATE OF ANALYSIS FOR CONCRETE

TL-TI-FORM-27 Version 2

Date: 08-05-2018

1. **Samples :**
  - 1.1 **Sample Description :**  
Concrete cube samples were delivered to this laboratory and tested.
2. **Nature of test :** Compressive Strength Test
3. **Test Method :** BS 1881 : Part 116 : 1983
4. **Results :**

**TEST RESULTS FOR CONCRETE CUBES**

<b>Project:</b>	Suitability of crushed ceramic and porcelain clay tiles as partial replacement of cement in concrete							
<b>Client:</b>	Student Research			<b>Method of Compaction:</b>	Hand Tamping			
<b>Curing Period:</b>	28 Days	<b>Testing Age:</b>	28 Days	<b>Technician:</b>	Alice			
<b>Concrete Class</b>	C25			<b>Design Strength</b>	25MPa			
<b>Treatment (%)</b>	5			<b>Slump</b>	58			
<b>DATE OF CAST</b>	<b>DATE TESTED</b>	<b>SAMPLE NUMBER</b>	<b>AREA OF USE</b>	<b>DIMENSIONS (mm)</b>	<b>WEIGHT (Kg)</b>	<b>DENSITY (Kg/m<sup>3</sup>)</b>	<b>CRUSHING LOAD (kN)</b>	<b>ULTIMATE COMPRESSIVE STRENGTH (N/mm<sup>2</sup>)</b>
29/03/2018	26/04/2018	1	Mass concrete and reinforced concrete	150*150*150	8.84	2619	762.0	33.87
		2			8.55	2533	853.7	37.94
<b>Average Compressive Strength</b>								<b>35.9</b>

5. **Remarks:**
  - 5.1 This report relates only to the samples tested.
  - 5.2 All tested samples will be immediately discarded after receipt of results by the client

Checked by:

Wangoda Vitalis  
Materials Engineer  
Teclab Limited

Client's representative :

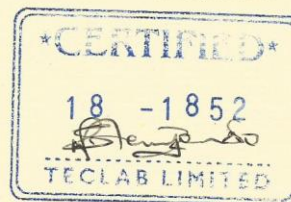

## CERTIFICATE OF ANALYSIS FOR CONCRETE

TL-TI-FORM-27 Version 2

Date: 08-05-2018

1. **Samples :**
- 1.1 **Sample Description :**  
Concrete cube samples were delivered to this laboratory and tested.
2. **Nature of test :** Compressive Strength Test
3. **Test Method :** BS 1881 : Part 116 : 1983
4. **Results :**

### TEST RESULTS FOR CONCRETE CUBES

<b>Project:</b>	Suitability of crushed ceramic and porcelain clay tiles as partial replacement of cement in concrete							
<b>Client:</b>	Student Research				<b>Method of Compaction:</b>	Hand Tamping		
<b>Curing Period:</b>	28 Days	<b>Testing Age:</b>	28 Days		<b>Technician:</b>	Alice		
<b>Concrete Class</b>	C25				<b>Design Strength</b>	25MPa		
<b>Treatment (%)</b>	10				<b>Slump</b>	55		
DATE OF CAST	DATE TESTED	SAMPLE NUMBER	AREA OF USE	DIMENSIONS (mm)	WEIGHT (Kg)	DENSITY (Kg/m <sup>3</sup> )	CRUSHING LOAD (kN)	ULTIMATE COMPRESSIVE STRENGTH (N/mm <sup>2</sup> )
05/04/2018	03/05/2018	1	Mass concrete and reinforced concrete	150*150*150	8.79	2604	761.7	33.85
		-2			8.52	2524	808.0	35.91
<b>Average Compressive Strength</b>								<b>34.9</b>

5. **Remarks:**
- 5.1 This report relates only to the samples tested.
- 5.2 All tested samples will be immediately discarded after receipt of results by the client

Checked by:

Wangoda Vitalis  
Materials Engineer  
Teclab Limited



Client's representative :

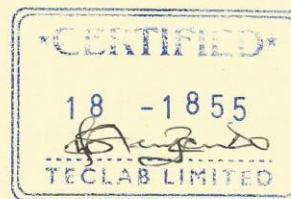

Page 1 of 1

## CERTIFICATE OF ANALYSIS FOR CONCRETE

TL-TI-FORM-27 Version 2

Date: 08-05-2018

1. **Samples :**
  - 1.1 Sample Description :  
Concrete cube samples were delivered to this laboratory and tested.
2. **Nature of test :** Compressive Strength Test
3. **Test Method :** BS 1881 : Part 116 : 1983
4. **Results :**

### TEST RESULTS FOR CONCRETE CUBES

<b>Project:</b>		Suitability of crushed ceramic and porcelain clay tiles as partial replacement of cement in concrete						
<b>Client:</b>		Student Research			<b>Method of Compaction:</b>		Hand Tamping	
<b>Curing Period:</b>	28 Days	<b>Testing Age:</b>	28 Days	<b>Technician:</b>		Alice		
<b>Concrete Class</b>	C25	<b>Design Strength</b>		25MPa				
<b>Treatment (%)</b>	15	<b>Slump</b>		50				
DATE OF CAST	DATE TESTED	SAMPLE NUMBER	AREA OF USE	DIMENSIONS (mm)	WEIGHT (Kg)	DENSITY (Kg/m <sup>3</sup> )	CRUSHING LOAD (kN)	ULTIMATE COMPRESSIVE STRENGTH (N/mm <sup>2</sup> )
06/04/2018	04/05/2018	1	Mass concrete and reinforced concrete	150*150*150	8.55	2533	687.9	30.57
		2			8.49	2516	653.8	29.06
<b>Average Compressive Strength</b>								29.8

5. **Remarks:**
  - 5.1 This report relates only to the samples tested.
  - 5.2 All tested samples will be immediately discarded after receipt of results by the client

Checked by:

  
 Wangoda Vitalis  
 Materials Engineer  
 Teclab Limited

Client's representative:



Page 1 of 1

## CERTIFICATE OF ANALYSIS FOR CONCRETE

TL-TI-FORM-27 Version 2

Date: 08-05-2018

1. **Samples :**
- 1.1 **Sample Description :**  
Concrete cube samples were delivered to this laboratory and tested.
2. **Nature of test :** Compressive Strength Test
3. **Test Method :** BS 1881 : Part 116 : 1983
4. **Results :**

### TEST RESULTS FOR CONCRETE CUBES

<b>Project:</b>		Suitability of crushed ceramic and porcelain clay tiles as partial replacement of cement in concrete								
<b>Client:</b>		Student Research				<b>Method of Compaction:</b>		Hand Tamping		
<b>Curing Period:</b>		28 Days		<b>Testing Age:</b>		28 Days		<b>Technician:</b>		Alice
<b>Concrete Class</b>		C25				<b>Design Strength</b>		25MPa		
<b>Treatment (%)</b>		20				<b>Slump</b>		49		
DATE OF CAST	DATE TESTED	SAMPLE NUMBER	AREA OF USE	DIMENSIONS (mm)	WEIGHT (Kg)	DENSITY (Kg/m <sup>3</sup> )	CRUSHING LOAD (kN)	ULTIMATE COMPRESSIVE STRENGTH (N/mm <sup>2</sup> )		
07/04/2018	5/05/2018	1	Mass concrete and reinforced concrete	150*150*150	9.17	2717	666.9	29.64		
		2			8.38	2483	654.6	29.09		
<b>Average Compressive Strength</b>								<b>29.4</b>		

5. **Remarks:**
- 5.1 This report relates only to the samples tested.
- 5.2 All tested samples will be immediately discarded after receipt of results by the client

Checked by:

Wangoda Vitalis  
Materials Engineer  
Teclab Limited

Client's representative :

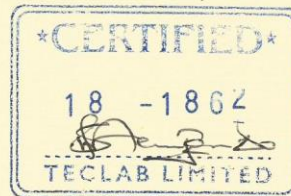

Page 1 of 1

### CERTIFICATE OF ANALYSIS FOR CONCRETE

TL-TI-FORM-27 Version 2

Date: 08-05-2018

1. **Samples :**
- 1.1 **Sample Description :**  
Concrete cube samples were delivered to this laboratory and tested.
2. **Nature of test :** Compressive Strength Test
3. **Test Method :** BS 1881 : Part 116 : 1983
4. **Results :**

**TEST RESULTS FOR CONCRETE CUBES**

<b>Project:</b>	Suitability of crushed ceramic and porcelain clay tiles as partial replacement of cement in concrete							
<b>Client:</b>	Student Research				<b>Method of Compaction:</b>	Hand Tamping		
<b>Curing Period:</b>	28 Days	<b>Testing Age:</b>	28 Days	<b>Technician:</b>	Alice			
<b>Concrete Class</b>	C25			<b>Design Strength</b>	25MPa			
<b>Treatment (%)</b>	25			<b>Slump</b>	46			
<b>DATE OF CAST</b>	<b>DATE TESTED</b>	<b>SAMPLE NUMBER</b>	<b>AREA OF USE</b>	<b>DIMENSIONS (mm)</b>	<b>WEIGHT (Kg)</b>	<b>DENSITY (Kg/m<sup>3</sup>)</b>	<b>CRUSHING LOAD (kN)</b>	<b>ULTIMATE COMPRESSIVE STRENGTH (N/mm<sup>2</sup>)</b>
09/04/2018	07/05/2018	1	Mass concrete and reinforced concrete	150*150*150	8.31	2462	486.5	21.62
		2			8.39	2486	472.9	21.02
<b>Average Compressive Strength</b>								21.3

5. **Remarks:**
- 5.1 This report relates only to the samples tested.
- 5.2 All tested samples will be immediately discarded after receipt of results by the client

Checked by:

Wangoda Vitalis  
Materials Engineer  
Teclab Limited

Client's representative :

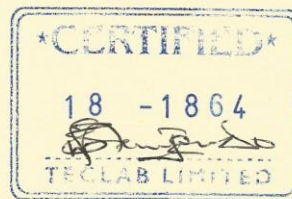

### CERTIFICATE OF ANALYSIS FOR CONCRETE

TL-TI-FORM-27 Version 2

Date: 08-05-2018

1. **Samples :**
  - 1.1 Sample Description :  
Concrete cube samples were delivered to this laboratory and tested.
2. **Nature of test :** Compressive Strength Test
3. **Test Method :** BS 1881 : Part 116 : 1983
4. **Results :**

**TEST RESULTS FOR CONCRETE CUBES**

<b>Project:</b>	Suitability of crushed ceramic and porcelain clay tiles as partial replacement of cement in concrete							
<b>Client:</b>	Student Research				<b>Method of Compaction:</b>	Hand Tamping		
<b>Curing Period:</b>	28 Days	<b>Testing Age:</b>	28 Days	<b>Technician:</b>	Alice			
<b>Concrete Class</b>	C25			<b>Design Strength</b>	25MPa			
<b>Treatment (%)</b>	30			<b>Slump</b>	44			
<b>DATE OF CAST</b>	<b>DATE TESTED</b>	<b>SAMPLE NUMBER</b>	<b>AREA OF USE</b>	<b>DIMENSIONS (mm)</b>	<b>WEIGHT (Kg)</b>	<b>DENSITY (Kg/m<sup>3</sup>)</b>	<b>CRUSHING LOAD (kN)</b>	<b>ULTIMATE COMPRESSIVE STRENGTH (N/mm<sup>2</sup>)</b>
10/04/2018	8/05/2018	1	Mass concrete and reinforced concrete	150*150*150	8.86	2625	532.4	23.66
		2			8.26	2447	483.7	21.50
<b>Average Compressive Strength</b>								22.6

5. **Remarks:**
  - 5.1 This report relates only to the samples tested.
  - 5.2 All tested samples will be immediately discarded after receipt of results by the client

Checked by:

Wangoda Vijaah  
Materials Engineer  
Teclab Limited

Client's representative :

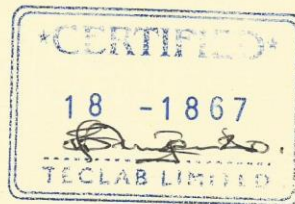

**Precautions during preparation of concrete cubes for testing**

- Concrete should be prepared in a clean place free from rubble, waste and other deleterious materials. The moulds should also be clean and adequately greased.
- Ensure that the constituent materials being used to produce the concrete i.e. aggregates, cement, water and additives are of quality that conforms to the appropriate standards.
- After the sample has been remixed, immediately fill the cube moulds (in layers) and compact the concrete, either by hand or by vibration. Any air trapped in the concrete will reduce the strength of the cube.
- Immediately mark cubes after casting by writing the details of the cube in ink on a small piece of paper and placing on top of the concrete until it is demoulded. Clear labels should be placed on each cube prior to curing.
- Transportation and handling of cubes should be done with care to prevent damage to the samples and subsequent inaccuracy in results.

**Expected Strength of Concrete**

Strength Class	Mix	Expected strength (N/mm <sup>2</sup> = MPa)		Area of Use
		7 days	28 days	
C-10	1:3:6 1:4:5	7.5	10	Typical house foundations, footings for garden walls
C-15	1:3:5	11.25	15	Foundation walls, basement walls, structural concrete, reinforced floor slabs, septic tanks, water storage tanks & stairways
C-20	1:3:4 1:2:4	15	20	Footing mixes in house construction in softer ground.
C-25	1:1.5:3 1:2:4	18.75	25	Foundations to larger houses. Can take light traffic and also suitable for lining pools
C-30	1:2:3	22.5	30	A general-purpose, easy-to-remember mix for many hardwearing applications.

Minimum grade for particular work such as reinforced concrete, pre-stressed concrete and for durability under particular environmental conditions are given in the appropriate code of practice.



## Appendix C: Material Cost of Production of 1 m<sup>3</sup> of Concrete

### Appendix C1: Material Breakdown for C25 cement concrete (1:2:3)

As obtained from the concrete mix design (section 4.2.2), materials required for 1:2:3 cement concrete mix – a commonly used grade of concrete for structural works are as follows;

- ❖ Wet (fresh) concrete mix = 1.0 m<sup>3</sup>
- ❖ Quantity for dry base analysis =  $1.4 \times 1.0 \text{ m}^3 = 1.4 \text{ m}^3$
- ❖ Volume of cement =  $1/6 \times 1.4 \text{ m}^3 = 0.23 \text{ m}^3$

But, 1 bag of cement equals to 0.035 m<sup>3</sup>

Thus, 0.23 m<sup>3</sup> of cement will require  $[(1/0.035) \times 0.23]$  bags = 6.8 bags

- ❖ Sand (fine aggregates) =  $2/6 \times 1.4 \text{ m}^3 = 0.47 \text{ m}^3$
- ❖ Coarse aggregates =  $3/6 \times 1.4 \text{ m}^3 = 0.70 \text{ m}^3$

Table C.1: Material breakdown for 1 m<sup>3</sup> of C25

No.	Material	Quantity required
1	Cement	340 kg = (0.23 m <sup>3</sup> )
2	Fine aggregates (Sand)	785 kg = (0.47 m <sup>3</sup> )
3	Coarse aggregates	1098 kg = (0.70 m <sup>3</sup> )
4	Water	180 litres = (0.18 m <sup>3</sup> )

## Appendix C2: Calculation of Unit Price of Concrete Production

### (a) Material Cost

Table C.2 gives material cost for 1 m<sup>3</sup> of conventional concrete mix.

Table C.2: Material cost for 1 m<sup>3</sup> of concrete with no cement replacement

Type and description of material	Unit	Qty	Rate (UgSh)	Cost per Unit (UgSh)
OPC, delivered and offloaded	bag	6.8	48,000	326,400
Lake sand, delivered on site	m <sup>3</sup>	0.47	45,000	21,150
Crushed angular aggregates delivered on site	m <sup>3</sup>	0.7	67,000	46,900
Tap stand of NW&SC Kampala	litre	180	42.30	7,614
			<i>Total</i>	<i>402,064</i>

The cost of acquiring crushed ceramic and porcelain powder was broken down as follows;

- To crush 2000 kgs of tile waste required 25 litres of fuel
- 1 litre of fuel costs averagely 4,000/=, thus amount of fuel required was 100,000/=
- Assume 20 % waste, this implies that 1,600 kgs of powder required 100,000/=
- Since 1 bag of cement contains 50 kgs
- 1,600 kgs produced  $(1,600 \div 50) = 32$  bags of ceramic and porcelain powder
- At optimal replacement of 20 % cement substitute, required  $(0.2 \times 6.8) = 1.36$  bags
- So if 32 bags cost 100,000/=, then 1.36 bags costs  $[(100,000 \div 32) \times 1.36] = 4,250/=$

Table C.3: Material cost for concrete with 20% cement replacement

Type and description of material	Unit	Qty	Rate (UgSh)	Cost per Unit (UgSh)
OPC, delivered and offloaded	bag	5.44	48,000	261,120
Crushed clay tile powders	bag	1.36	3,125	4,250
Lake sand, delivered on site	m <sup>3</sup>	0.47	45,000	21,150
Crushed angular aggregates delivered on site	m <sup>3</sup>	0.7	67,000	46,900
Tap stand of NW&SC Kampala	litre	180	42.30	7,614
			<i>Total</i>	<i>341,034</i>

**(b) Labour Cost**

The crew consists of the following workers.

- Site Engineer 2,000,000/= per month.

Therefore, Labour = 2,000,000 / (22 days × 8 hrs/day) = 11,364/= per hour.

For utilization factor of 1/10 (10 foremen under him) = 11,364 × (1/10) = 2.27/= per hour.

- Forman daily wage = 24,000/= per day = 24,000/8 = 3,000/= per hour.

For a utilization factor of 1/4 (for 4 labourers under him) = 3,000 × (1/4) = 750/= per hour.

- Mason daily wage = 20,000/= per day = 20,000/8 = 2,500/= per hour, (UF = 1.0).

- Assistant mason daily wage = 16,000/= per day = 16,000/8 = 2,000/= per hour,

- Daily labourers daily wage = 12,000/= per day = 12,000/8 = 1,500/= per hour, Total cost per unit time = [11,364 + 3,000 + 2,500 + 2,000 + (1,500 × 2)] = 21,864/= per hour.

Assume Labour output (productivity) for the work = 2 m<sup>3</sup> per day = 0.25 m<sup>3</sup> per hour

$$\begin{aligned}
\therefore \text{Labour Cost (LC)} &= \text{Cost per unit time} \div \text{productivity} \\
&= (21,864) \div (0.25) \\
&= 87,456/= \text{ per m}^3
\end{aligned}$$

**(c) Equipment Cost**

Consider a concrete mixer of capacity 2 m<sup>3</sup> per hour and a poker vibrator to be hired at 100,000/= per day and 40,000/= per day of 8 working hours respectively.

- Cost of concrete mixer to produce 1 m<sup>3</sup> = (100,000) ÷ (8 × 2) = 6,250/=
- Cost of poker vibrator required to produce 1 m<sup>3</sup> = (40,000) ÷ (8 × 2) = 2,500/=

$$\therefore \text{Equipment Cost (EC)} = (6,250 + 2,500) = 8,750/= \text{ per m}^3$$

## Appendix D: Environmental Impact Considerations

### Appendix D1: Abiotic depletion

The value obtained for 1kg Portland cement is shown in Table D.1.

Table D.1: Embodied energy of Portland cement production (1 kg)

	Clinker		Cement powder		Total (MJ/kg)
	E thermal (MJ/kg)	Electricity (MJ/kg)	E thermal (MJ/kg)	Electricity (MJ/kg)	
1 kg of Portland Cement	4.17	0.26	0.124	0.29	4.85
	86 %	5.4 %	2.6 %	6 %	100 %

*Assessing the Energy requirement for acquiring 1 kg of ceramic and porcelain powders*

To crush 2000 kgs of tile waste required 25 litres of fuel.

1 litre of diesel industrial use is equivalent to 39.6 Mega Joules (MJ) of energy

This implies that, 25 litres will be equivalent to  $(25 \times 39.6) = 990$  MJ

If 2000 kgs of tile waste requires 990 MJ of energy, with 1800 kg acquired (considering 20 % waste during the crushing process)

Then, 1 kg would require  $(990 \div 1,600) = 0.61875$  MJ per kg of waste powder.

## **Appendix D2: Global warming**

Carbon dioxide (CO<sub>2</sub>) is a by-product of a chemical conversion process used in the production of clinker. CO<sub>2</sub> is also emitted during cement production by fossil fuel combustion and is accounted for elsewhere.

### Assessing CO<sub>2</sub> emission in production of cement

The global production of cement has grown very rapidly in recent years, and after fossil fuels and land-use change, it is the third-largest source of anthropogenic emissions of carbon dioxide. According to Robbie, (2018) the global process emissions from cement production reached a peak in 2014 of  $1.51 \pm 0.12$  GtCO<sub>2</sub>, subsequently declining slightly to  $1.46 \pm 0.19$  Gt CO<sub>2</sub> in 2016. In comparison, the estimate for 2014 is 2.08 GtCO<sub>2</sub> (Boden *et al.*, 2017). The most recent estimate currently available is for 2015 at 1.44 GtCO<sub>2</sub> (Olivier *et al.*, 2016).

- Global cement production per year =  $4,200 \times 10^6$  tons
- Global process CO<sub>2</sub> emission per year =  $1.44 \times 10^9$  tons
- Therefore, CO<sub>2</sub> emission per ton of cement =  $(1.44 \times 10^9) \div (4,200 \times 10^6)$   
= 0.343 tons

### Assessing CO<sub>2</sub> emission in production of ceramic and porcelain powder

To crush 2000 kgs of tile waste required 25 litres of fuel.

According to comcar.co.uk,

- If you burn a litre of diesel this will produce 2.6391 kgs of carbon dioxide,
  - This implies that, 25 litres will be equivalent to  $(25 \times 2.6391) = 65.9775$  kgs of CO<sub>2</sub>
  - Also, 1000 kgs is equivalent to 1 ton
  - Hence, 65.9775 kgs is equivalent to  $(65.9775 \div 1000) = 0.0659775$  tons
- ∴ CO<sub>2</sub> emission in production of ceramic and porcelain powder is 0.0659775 tons

## **Appendix E: Publications**

# Physical and Mechanical Experimental Investigation of Concrete incorporated with Ceramic and Porcelain Clay Tile Powders as Partial Cement Substitutes

Morris Oleng

Post Graduate Student

Department of Civil Engineering

PAN AFRICAN UNIVERSITY Institute for Basic Sciences,  
Technology and Innovation (PAUSTI)  
Nairobi, Kenya

Christopher Kanali

Professor

Dept. of Agricultural and Biosystems Engineering  
Jomo Kenyatta University of Agriculture and Technology  
Nairobi, Kenya

Zachary C. Abiero Gariy

Professor

Department of Civil Engineering

Jomo Kenyatta University of Agriculture and Technology  
Nairobi, Kenya

Erick Ronoh

Doctor

Dept. of Agricultural and Biosystems Engineering  
Jomo Kenyatta University of Agriculture and Technology  
Nairobi, Kenya

**Abstract**— The increased demand of construction over the past two decades has led to drastic increase in the cost of concrete production. The increasing cost and scarcity of portland cement has impacted negatively on the delivery of affordable housing and infrastructural development in developing countries like Uganda. For this reason, there is urgent need for finding suitable alternatives which can replace cement partially or at a high proportion. This study focussed on establishing the feasibility of using crushed ceramic and porcelain clay tiles powder as partial replacement of cement in production of eco-friendly concrete. Concrete cubes measuring 150 mm × 150 mm × 150 mm and 100 mm × 200 mm cylinder specimens were made from seven different concrete mixes prepared by using crushed ceramic and porcelain clay tile powder to replace 0%, 5%, 10%, 15%, 20%, 25% and 30% of ordinary portland cement by mass. The workabilities of the fresh concrete mixes were evaluated using the slump while compressive and splitting tensile strengths of hardened concrete were evaluated at different curing periods of 7, 14, and 28 days. The results of slump test showed that increase in ceramic and porcelain powder replacement decreased the workability of concrete. Replacement of cement with ceramic and porcelain powder significantly increased the compressive strength of concrete. Conclusively, the target compressive and tensile splitting strengths were achieved up to 20% replacement of cement with ceramic and porcelain powder beyond which the strength reduced.

**Keywords**— *Cement; Ceramic And Porcelain Clay Tile Powder; Concrete; Workability; Compressive Strength; Splitting Tensile Strength*

## I. INTRODUCTION

The construction industry constitutes one of the main contributors to the economy of any country (about 10% of the gross domestic product). It plays a huge role in not only economic development but also improving the welfare of the citizens. Recently, the growth rate in construction has increased drastically by over 1.8% globally with the largest contributors

to the construction market being Europe, America, Asia and Japan as they control more than 70% of the industry [22]. Concrete is the world most utilized construction material and due to this, statistics have shown that worldwide cement production, by major producing countries from 2011 to 2016 has drastically increased and so has its cost [23]. Additionally, the growing concern of depletion of resources necessitates the search for alternatives sources [1]. For these reasons, there is need for increased initiatives to modify ordinary concrete to make it more sustainable and affordable so as to cater for the increasing construction boom [18].

Different studies have been done with interest driven much towards wastes and recycled materials as they are economical and more environmental friendly. Such studies reported include replacing cement with animal blood, partial replacement with waste glass powder, replacing cement with rice husks, replacement with saw dust, replacement by steel shot dust, using kiln saw dust and many others [21]. Particularly, ceramic materials which include brick walls, ceramic tiles and all the ceramic products contribute the highest proportion of wastes in the construction and demolition waste [17]. Ceramic tile is a product that stands out for its low water absorption and high mechanical strength. The properties of the product result from its low porosity due to the processing conditions (high degree milling of raw materials, high force compaction and sintering temperature), and the potential of the raw materials to form liquid phases during sintering (high desiccation). Porcelain tile on the other hand has high vitreous characteristics [20].

This study, therefore, seeks to assess the suitability of utilizing old waste tiles from demolished structures in order to reduce waste around cities such as Kampala. The properties of crushed ceramic and porcelain clay tile powder were determined. Cement was partially replaced 0%, 5%, 10%, 15%, 20%, 25%, and 30% of crushed ceramic and porcelain clay tile powder in M25 concrete.



II. MATERIALS AND METHODS

A. Cement, Ceramic and Porcelain clay tile powders

Cement is a hydraulic binder, finely ground inorganic material that, when mixed with water, forms concrete which is a composite material consisting of a binder, typical cement, and rough and fine aggregates, which are usually stone and sand, and water. The cement used was Ordinary Portland Cement (OPC) which is the most common type of cement used in Uganda, particularly Tororo cement brand of OPC conforming to BS EN 197-1:2000 [15], of strength class 32.5. Samples of ceramic and porcelain clay tiles were taken from of the five demolition sites within Kampala metropolitan area in accordance to BS 1881-101: 2011 [6], which gives methods of sampling. The chemical composition of the ceramic and porcelain clay tile powder was determined using X-Ray Fluorescence Spectrometer method while the physical properties were determined as specified in ASTM C 187 [2] and ASTM C 188 [3]. A comparison between the properties of ceramic and porcelain powders with cement properties was made to verify if their composition warrants it as a pozzolan. The physical properties of cement, ceramic and porcelain powders are presented in Table I.

TABLE I. PHYSICAL PROPERTIES OF CEMENT, CERAMIC AND PORCELAIN CLAY TILE POWDERS

Property	Ordinary Portland Cement	Ceramic Powder	Porcelain Powder
Specific Gravity	3.15	2.95	3.11
Consistency	30	32.5	35.0
Initial Setting Time	30 minimum	70	45
Final Setting Time	540 maximum	475	320

The major compounds of ordinary portland cement, ceramic and porcelain powders are given in Table II. About 95% of portland cement clinker is made of combinations of four oxides. These are; lime (CaO), silica (SiO<sub>2</sub>), alumina (Al<sub>2</sub>O<sub>3</sub>), and iron oxide (Fe<sub>2</sub>O<sub>3</sub>). Other, so-called minor constituents or impurities include, among others, magnesia; sodium, and potassium oxides. Since the primary constituents of portland cement are calcium silicates, we can define Portland cement as a material that combines CaO and SiO<sub>2</sub> in such a proportion that the resulting calcium silicate will react with water at room temperature and normal pressure.

TABLE II. CHEMICAL COMPOSITION OF CEMENT, CERAMIC AND PORCELAIN CLAY TILE POWDER

Component	Percentage by mass		
	Ordinary Portland Cement	Ceramic Powder	Porcelain Powder
SiO <sub>2</sub>	21.03	66.39	73.04
CaO	64.67	3.64	1.43
Al <sub>2</sub> O <sub>3</sub>	6.16	18.14	19.39
Fe <sub>2</sub> O <sub>3</sub>	2.58	3.79	1.42
MgO	2.62	3.60	1.58
K <sub>2</sub> O	0.61	3.39	2.56

From the Table II it can be seen that the combined percentage of SiO<sub>2</sub>, Fe<sub>2</sub>O<sub>3</sub> and Al<sub>2</sub>O<sub>3</sub> for both crushed ceramic and porcelain clay tile powder was 88.32% and 93.85% respectively, thus meeting the 70% minimum requirement of ASTM C 618 [4] for a good pozzolan.

B. Fine Aggregates

From the sieve analysis of the fine aggregates, all the sand passed the 37.5 mm and 28 mm sieves; a moderate amount was retained on 10 – 0.6 mm sieves while 1.7% was silt. These showed that the aggregates were uniformly graded since they are relatively evenly retained on each sieve, hence they were

suitable aggregates for concrete requirements BS 882:1992 [13]. The physical properties of the fine aggregates are presented in Table III.

TABLE III. PHYSICAL PROPERTIES OF FINE AGGREGATES								
BS 882:1992	Sieve Analysis (% passing given sieve)							
Sieve (mm)	20.0	10.0	5.0	2.0	1.18	0.60	0.30	0.15
Limits	100	100	100-89	100-60	100-30	100-15	70-5	15-0
% Passing	100	99.2	91.0	73.9	58.1	20.3	6.4	1.7
Moisture Content	Specific Gravity			Silt Content				
4.4 %	2.6 Mg/m <sup>3</sup>			1.5 %				

A plot of cumulative percentage passing against the sieve sizes done on a graph containing the sieve envelope as shown in Fig. 1. Uniformly graded aggregates enhance the workability of concrete by minimizing the voids in the mix as the voids will be filled by smaller particles of the aggregates and no bleeding.

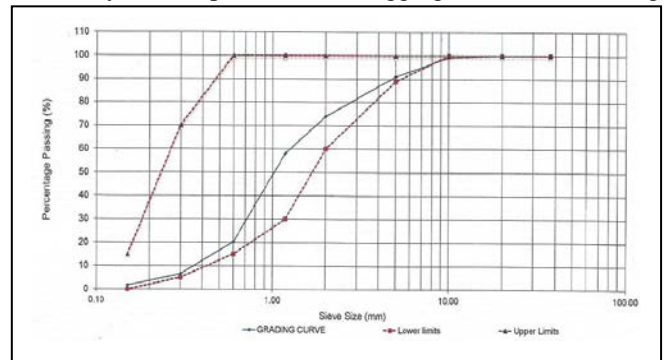

Fig. 1: Particle Size Distribution of Fine aggregates

C. Coarse Aggregates

The fractions from 20 mm to 4.75 mm are used as coarse aggregate. Machine crushed angular granite metal of 20 mm nominal size from the local source was used as coarse aggregate. It was free from impurities such as dust, clay particles and organic matter etc. The coarse aggregate chosen for concrete was typically angular in shape, dense graded, and smaller than maximum size suited for conventional concrete. The physical properties were investigated in accordance with BS 882:1992 [13]. Table IV shows the physical properties of the coarse aggregates and the particle size distribution is shown in Fig. 2.

TABLE IV. PHYSICAL PROPERTIES OF COARSE AGGREGATES	
Property	Value
Specific Gravity	2.7 Mg/m <sup>3</sup>
Water Absorption	1.1 %
Bulk Density	1.5 g/m <sup>3</sup>

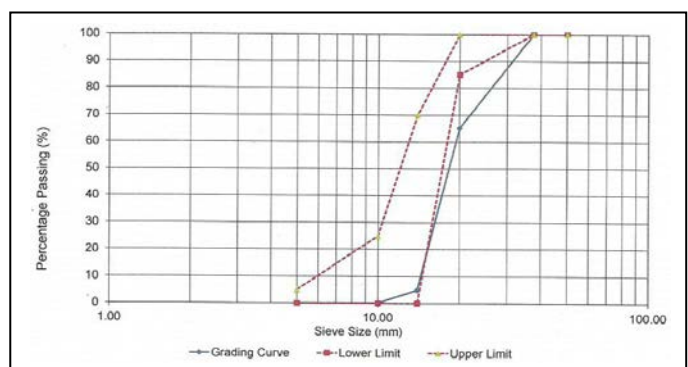

Fig. 2: Particle Size Distribution of Coarse aggregates Water for mixing concrete

Water is an important ingredient of concrete as it actually participates in the chemical reaction with cement. Since it gives the strength to cement concrete, the quantity and quality of water were required to be looked into very carefully. Potable tap water free from any injurious amounts of oils, acids, alkalis, sugar, salts and organic materials available in the laboratory with pH value of  $7.0 \pm 1.0$  and conforming to the requirements of BS EN 1008:2002:1980 [14] was used for mixing concrete and curing the specimens. The water source was tap stand of National Water and Sewerage Corporation (NW&SC) Kampala branch.

**D. Concrete Mix Design**

A control mix of ratio 1:2:3 batched by mass using a water-cement ratio of 0.50 was used. The control mix was produced using OPC only as binder while in other mixes, crushed ceramic and porcelain clay tile powder was used to partially replace 5%, 10%, 15%, 20%, 25% and 30% by mass of ordinary portland cement in the control mix. The details of mix proportions are shown in Table V.

TABLE V. CONCRETE MIX PROPORTIONS

Percentage Cement Replacement (%)	Mass of constituents (kg)			
	Cement	Ceramic & Porcelain Powder	Fine Aggregates	Coarse aggregates
0	1.33	0	2.38	3.71
5	1.26	0.07	2.38	3.71
10	1.20	0.13	2.38	3.71
15	1.13	0.20	2.38	3.71
20	1.06	0.27	2.38	3.71
25	1.00	0.33	2.38	3.71
30	0.93	0.40	2.38	3.71

Mixing method was done manually with a control mechanism to prevent the loss of water quantified for the mixing purpose. Concrete mix was made using a binder, sand and coarse aggregates [21]. The specimens were casted in moulds generally 150 mm cubes. The mould surface was cleaned and oiled on their inside surfaces in order to prevent development of bond between the moulds and the concrete. Curing may be defined as the procedures used for promoting the hydration of cement, and consists of a control of temperature and of the moisture movement from and into the concrete. Sample of cubes were taken from the moulds after 24 hours of casting and then cured for 7, 14, and 28 days prior to testing. Testing equipment was the Universal Testing Machine (UTM) as specified in BS 1881-115:2011. The compressive strength of each cube was calculated by dividing the maximum load applied to it by the cross-sectional area according to BS 1881-116:2011 [9]. The splitting tensile strength test was conducted in accordance to BS 1881-117:2011 [5].

**E. Experimental Setup**

A mix ratio of 1:2:3 batched by mass using a water-cement ratio of 0.50 was used. The control mix was produced using OPC only as binder while in other mixes, crushed ceramic and porcelain clay tile powder was used to partially replace 5, 10, 15, 20, 25 and 30% by mass of ordinary portland cement in the control mix. Laboratory tests were carried out on fresh and hardened concrete. As a measure of workability, Slump test was carried out on the fresh concrete for all concrete mixes. For the hardened concrete, the compressive strength and split tensile strength tests were carried out in accordance to the appropriate standards. Test cubes and cylinders were taken

from the moulds after 24 hours of casting and then cured for 7, 14, and 28 days prior to testing. The performance of concrete with various treatments at different ages was monitored to establish the optimal mix.

The flow chart for evaluating the performance of concrete with ceramic and porcelain clay tile powders as partial cement replacements is shown in Fig. 3. The study was operated by varying amounts of tile powder in concrete production by either weight and volume or the percentage of concrete.

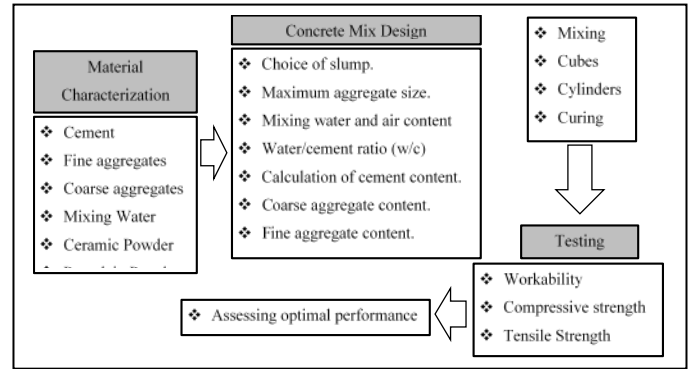

Fig. II. Flow chart for evaluating the performance of concrete mix obtained from ceramic and porcelain clay tile powders as partial cement substitutes

**III. RESULTS AND DISCUSSION**

**A. Workability of Fresh Concrete**

The results of the slump test for various replacement levels is presented in Fig. 4.

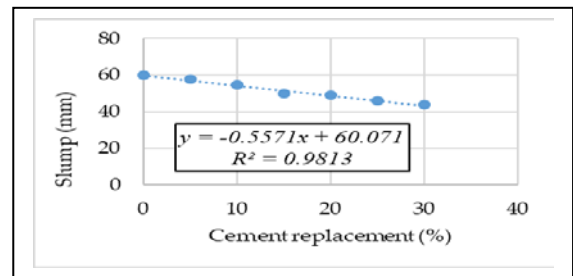

Fig. 4. Workability against percentage replacement

From the results in Fig. 4, it can be seen that as the percentage replacement of OPC with crushed ceramic and porcelain clay tile powder increases, the workability of concrete decreases. There was a reduction in the workability levels as reported by a reduction in the slump values from 60 mm for normal concrete at percentage reductions of 3.33%, 8.33%, 16.67%, 18.33%, 23.33% and 26.67% for 5%, 10%, 15%, 20%, 25% and 30% crushed ceramic and porcelain clay tile powder partial replacement of cement respectively as compared to the control. Replacing cement by an equal mass of crushed ceramic and porcelain clay tile powder causes an increase in volume since the density of cement is higher than that of crushed ceramic and porcelain clay tile powder. This therefore increases the water demand and as the crushed ceramic and porcelain clay tile powder content increases the workability reduces since the quantity of water remains the same for all mixes. Also a reduction in the workability of fresh concrete may be caused by an adhesion within the concrete and

holding the other ingredients of concrete together impeding easy flow of water as was reported by Nibudey [19].

### B. Compressive Strength

The results of compressive strength test are presented in Fig. 5. Concrete derives its strength from the pozzolanic reaction between silica in pozzolan and the calcium hydroxide liberated during the hydration of OPC. In the very first period after the adsorption of water on the surface of the dry powder, the dissolution of part of the inorganic phases starts to occur. Very soon, however, new silicate and aluminate hydrated phases begin to precipitate from the solution on the existing grains, thus favouring the further dissolution of the anhydrous phases through an incongruent process. The hydrated phase responsible for the binding characteristics of the cement is an amorphous calcium silicate hydrate, called C-S-H, having the properties of a rigid gel. A secondary product of the hydration process is crystalline  $\text{Ca}(\text{OH})_2$ , portlandite. The reaction of the silicate and aluminate phases with water is an exothermic process. The C-S-H gel is not only the most abundant reaction product, occupying about 50% of the paste volume, but it is also responsible for most of the engineering properties of cement paste. This is because it forms a continuous layer that binds together the original cement particles into a cohesive whole. The ability of the C-S-H gel to act as a binding phase arises from its nanometer-level structure.

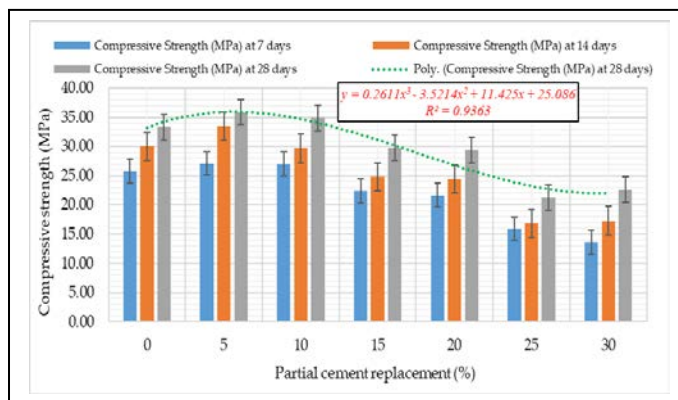

Fig. 5. Compressive strengths for various cement replacement levels at different ages.

At low percentages of replacement, the quantity of silica is low, therefore, only a limited quantity of C-S-H can be formed despite the large quantity of calcium hydroxide liberated due to the relatively large quantity of portland cement. However, at high percentage replacement, the quantity of pozzolan in the mix increases. C-S-H formed reduces due to liberation of a small quantity of calcium hydroxide from the hydration of the relatively small quantity of portland cement available. The strength of concrete at both low and high percentage replacement is therefore low. An optimum level of replacement exists at which compressive strength is the highest. It can also be concluded that the strength of concrete depends on the relative proportions of silica in crushed ceramic and porcelain powder and ordinary portland cement available.

The optimum reaction take place at 5% replacement of OPC hence the rate of strength gain with respect to time is highest for concrete with 5% replacement of OPC by crushed ceramic and porcelain powder. The variation of compressive strength of concrete is presented in Figure 4. The target compressive strength at 28 days was achieved up to 20% replacement of cement with crushed ceramic and porcelain clay

tile powder beyond which the addition reduces the strength. This trend is similar at all ages of testing. It is also seen that the strength of concrete increases with age.

### C. Splitting Tensile Strength

Knowledge of tensile strength of concrete is of great importance. Tensile strength was determined using Universal Testing Machine (UTM). The split tensile strength of concrete was tested using 100 mm × 200 mm cylinder specimens and carried out by placing specimen between the loading surfaces of a UTM and the load was applied until the failure of the specimen. Three test specimens were cast for each proportion and used to measure the tensile strength for each test conditions and average value was considered. The average values of 3 specimens for each category at the ages of 7 days, 14 days and 28 days are shown in the Fig. 6.

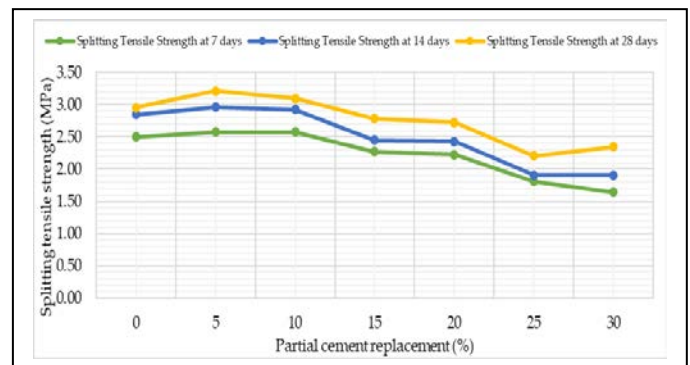

Fig. 6. Splitting tensile strengths for various cement replacement levels at different ages.

Fig. 6 shows that there was an improvement in the tensile splitting values up to 10 % cement replacement with ceramic and porcelain powder at 7 days, 14 days and 28 days curing times. The target tensile strength was achieved up to 20 % cement replacement with ceramic and porcelain powder.

## IV. CONCLUSION

- Increase in crushed ceramic and porcelain clay tile powder replacement decreased the workability of concrete (Fig. 4).
- Replacement of cement with crushed ceramic and porcelain clay tile powder significantly increased the compressive strength of concrete.
- Replacement of 5% of the mass of cement with crushed ceramic and porcelain clay tile powder achieved the maximum compressive strength (Fig. 5). The 7-day, 14-day, and 28-day compressive strengths at 5% replacement respectively showed increases of 5%, 12% and 8% over the compressive strength of the control concrete at those ages.
- The 28-day compressive strengths at 20% replacement showed increases of 18% compared to the target compressive strength of M25. Hence the replacement of cement using 20% crushed ceramic and porcelain clay tile powder in concrete gives the required strength and can be considered as optimum percentage (Fig. 5). Further increase in the percentage addition of ceramic waste, reduces the compressive strength of concrete by 56% at 28 days.

- The 28-day splitting tensile strengths was achieved up to 20% replacement and it showed increases of 8.2% compared to the target tensile strength of M25 (Fig. 6).

#### ACKNOWLEDGMENT

The authors are greatly indebted to African Union Commission (AUC) and Japan International Cooperation Agency (JICA) for funding this research through Africa-ai-Japan Project (African Union-African Innovation-JKUAT and PAUSTI Network Project) under the Africa-ai-Japan Innovation Research Grant 2017/18 (JKU/ADM/10B).

#### REFERENCES

- [1] Agbede, O. I., & Monash, J., (2009). Suitability of Periwinkle Shell as Partial Replacement for Gravel in Concrete. *Leonardo Electronic Journal of Practice and Technologies*, (15), 56-66.
- [2] ASTM C 187 – 16, Standard Test Method for Amount of Water Required for Normal Consistency of Hydraulic Cement Paste. ASTM International, Pennsylvania.
- [3] ASTM C 188 – 17, Standard Test Method for Density of Hydraulic Cement. ASTM International, Pennsylvania.
- [4] ASTM C 618, (2005), Standard specification for coal fly ash and raw or calcined natural pozzolan for use in concrete. USA: ASTM International. [www.astm.org/standards/C618.htm](http://www.astm.org/standards/C618.htm): pp. 1 – 623.
- [5] BS 1881 Part 117 (2011). Testing concrete. Method for determination of tensile splitting strength. British Standards Institution, London, UK.
- [6] BS 1881-101:2011. Testing concrete. Method of sampling fresh concrete on site, British Standard Institution, London, UK.
- [7] BS 1881-102:2011. Testing concrete. Method for determination of slump, British Standard Institution, London, UK.
- [8] BS 1881-111:2011. Testing concrete. Method of normal curing of test specimens, British Standard Institution, London, UK.
- [9] BS 1881-115:2011. Testing concrete. Specification for compression testing machines for concrete, British Standard Institution, London, UK.
- [10] BS 1881-116:2011. Testing concrete. Method for determination of compressive strength of concrete cubes. British Standards Institution, London, UK.
- [11] BS 812-1:1975, Methods for determination of particle size and shape, British Standard Institution, London, UK.
- [12] BS 812-2:1995, Methods of determination of density, British Standard Institution, London, UK.
- [13] BS 882 (1992), Specification for aggregates from natural sources for concrete. British Standards Institution, London, UK.
- [14] BS EN 1008:2002. Mixing water for concrete — Specification for sampling, testing and assessing the suitability of water, including water recovered from processes in the concrete industry, as mixing water for concrete, British Standards Institution, London, UK.
- [15] BS EN 197-1:2000, Cement - Part 1: Composition, specifications and conformity criteria for common cements, British Standard Institution, London, UK.
- [16] BS EN 933-2:1996. Tests for geometrical properties of aggregates — Determination of particle size distribution — Test sieves, nominal size of apertures, British Standard Institution, London, UK.
- [17] Meena, A. V. J., (2017). Experimental Study of Ceramic Waste Electric Insulator Powder Used as a Partial Replacement of Cement in Concrete. *Journal of Materials Science & Surface Engineering*, 5(4): 606-611
- [18] Naik, T. R., Kraus, R., & Siddique, R. N., (2003). Controlled low-strength materials containing mixtures of coal ash and new pozzolanic material. *Materials Journal*.
- [19] Nibudey, R. N., Nagarnaik, P. B., Parbat, D. K., Pande, A. M., & Polytechnic, G. (2014). Compressive Strength and Sorptivity Properties of PET Fiber Reinforced Concrete, 7(4), 1206–1216.
- [20] Pérez, J. M., Rincón, J. M., & Romero, M., (2012). Effect of moulding pressure on microstructure and technological properties of porcelain stoneware. *Ceramics International*, 38(1), 317-325.
- [21] Prabagar, S., Kalya, S., & Kerthi, W. R. F., (2015). Wood ash as an effective raw material for concrete blocks. *International journal of research in engineering and technology*, Environmental Technology Section, Industrial Technology Institute, 363, Baudhdhaloka Mawathe.
- [22] Wadel, G., (2009). Sustainability in industrialized architecture: Modular lightweight construction applied to housing. Doctoral Thesis, Polytechnic University of Catalonia-Department of Architectural Constructions.
- [23] Xi, F., Davis, S. J., Ciaisi, P., Crawford-Brown, D., Guan, D., Pade, C., & Bing, L., (2016). Substantial global carbon uptake by cement carbonation. *Nature Geoscience*, 9(12), 880-883.

# IJERT

ISSN : 2278 - 0181

Call for  
Papers  
2018

OPEN  ACCESS

  
Click Here  
for more  
details

## International Journal of Engineering Research & Technology

- ✓ Fast, Easy, Transparent Publication
- ✓ More than 50000 Satisfied Authors
- ✓ Free Hard Copies of Certificates & Paper

Publication of Paper : Immediately after  
Online Peer Review

### Why publish in IJERT ?

- ✓ Broad Scope : high standards
- ✓ Fully Open Access: high visibility, high impact
- ✓ High quality: rigorous online peer review
- ✓ International readership
- ✓ Retain copyright of your article
- ✓ No Space constraints (any no. of pages)

Submit  
your  
Article

[www.ijert.org](http://www.ijert.org)

# Physical and Chemical Properties of Crushed Ceramic and Porcelain Clay Tile Powder

**Oleng Morris**, PG Student, Department of Civil Engineering, Pan African University Institute for Basic Sciences, Technology and Innovation (PAUSTI), Nairobi, Kenya

**C. Kanali**, Professor, Department of Agricultural and Biosystems Engineering, Jomo Kenyatta University of Agriculture and Technology (JKUAT), Nairobi, Kenya

**Zachary C. A. Gariy**, Professor, Department of Civil Engineering, Jomo Kenyatta University of Agriculture and Technology (JKUAT), Nairobi, Kenya

**E. Ronoh**, Doctor, Department of Agricultural and Biosystems Engineering, Jomo Kenyatta University of Agriculture and Technology (JKUAT), Nairobi, Kenya

## ABSTRACT

*This study focussed on establishing the physical and chemical properties of crushed ceramic and porcelain clay tiles for use as partial replacement of cement in production of eco-friendly concrete. Samples of ceramic and porcelain clay tiles were taken in accordance to BS 1881-101: 1983, which gives methods of sampling. Five kilograms of each material (ceramic and porcelain clay tiles) was picked from each of the five sampled sites within Kampala metropolitan area. The chemical composition of the ceramic and porcelain clay tile powder was determined using X-Ray Fluorescence Spectrometer method while the physical properties were determined using the ASTM C187 and ASTM C188. A comparison between the properties of the waste materials and cement was made to verify if its composition warrants it to be used as a pozzolan. The results show that the combined percentage of silica ( $\text{SiO}_2$ ), Iron Oxide ( $\text{Fe}_2\text{O}_3$ ), and Alumina ( $\text{Al}_2\text{O}_3$ ) for both crushed ceramic and porcelain clay tile powder was meeting the 70% minimum requirement of ASTM C 618 for a good pozzolan.*

## Keywords

*Ceramic powder; porcelain powder; physical and chemical properties*

## 1. INTRODUCTION

Ceramic is defined as inorganic and non – metallic solids which can be highly crystalline, semi crystalline, vitrified or completely amorphous. Ceramics are grouped into two main groups which include the crystalline ceramics and

the non-crystalline ceramics. The crystalline ceramics are found to be non-submissive to the wide range of processing and hence the crystalline ceramic is prepared in a desired shape either by reaction on site or by forming powders in the desired shape and then heating it until it becomes a solid mass. On the other hand, the non-crystalline ceramics are made from melts. The shape of the glass is formed either on a molten state or when it is in a toffee like viscosity (Sivaprakash et al., 2016).

Ceramic wastes can be separated in two categories in accordance with the source of raw materials. The first one are all fired wastes generated by the structural ceramic factories that use only red pastes to manufacture their products, such as brick, blocks and roof tiles. The second one is all fired waste produced in stoneware ceramic such as wall, floor tiles and sanitary ware. These producers use red and white pastes; nevertheless, the usage of white paste is more frequent and much higher in volume. (Pacheco et al., 2010).

Porcelain tile is a highly vitrified material produced from a body formulated by mixtures of kaolin, quartz and feldspar. The kaolin [ $\text{Al}_2\text{Si}_2\text{O}_5(\text{OH})_4$ ], gives plasticity to the mixture; flint or quartz ( $\text{SiO}_2$ ), maintains the shape of the formed article during sintering; and feldspar [(K, Na) $_2\text{O} \cdot \text{Al}_2\text{O}_3 \cdot 6\text{H}_2\text{O}$ ], serves as flux. These three constituents place porcelain in the phase system [(K, Na) $_2\text{O} - \text{Al}_2\text{O}_3 - \text{SiO}_2$ ] in terms of oxide constituents, hence the term triaxial porcelain tiles (Buchanan, 1991 and Olupot, 2006). The main phase composition of a porcelain body is constituted by a heterogeneous glassy matrix and needle shaped mullite crystals together with some quartz grains and closed irregular shaped pores. Because of the

complex interplay between raw materials, processing routes and the kinetics of the firing process, porcelains represent some of the most complicated ceramic systems (Lopez, 2011).

The differences between ceramic and porcelain tile lies in the fact that both are made with clay, but ceramic tiles also have sand mixed in. Porcelain tile tends to be made with denser clay than ceramic. Ceramic tile is a product that stands out for its low water absorption and high mechanical strength. The properties of the product result from its low porosity due to the processing conditions (high degree milling of raw materials, high force compaction and sintering temperature), and the potential of the raw materials to form liquid phases during sintering (high desiccation). Porcelain tile on the other hand is a type of ceramic material which has high vitreous characteristics. (Perez et al., 2013). This study, therefore, seeks to establish the physical and chemical properties of crushed ceramic and porcelain clay tiles obtained from demolished structures around Kampala metropolitan and its environs.

## 2. LITERATURE REVIEW

A number of researches have been carried out to find the properties of ceramic and porcelain tiles. Braganca et al. (2004) investigated the mechanical properties of porcelain. They reported the optimum sintering temperature for the porcelain studied was 1340° C using a heating rate of 150 C/h and a 30 min soaking time. The authors recorded the technical parameters are summarized such as water absorption: 0.34%, apparent porosity: 0.84%, bulk density: 2.48 g/cm<sup>3</sup> linear shrinkage: 12.2% modulus of rupture: 46 MPa. The authors added that the maximum strength is a result of decrease in porosity and internal flaws. Samples fired at temperatures below the ideal (1340° C) showed open porosity. On the microstructural analysis Braganca et al. (2004) revealed that the ideal firing temperature occurs when the glassy phase covers the entire sample surface with sufficient time to react with crystalline phases. Higher temperatures were limited by the porosity increase. This porosity is a result of oxygen released from Fe<sub>2</sub>O<sub>3</sub> decomposition and gas expansion in the pores.

Stathis (2004) asserts that filler grain size has severe impact on the mechanical and physical properties of porcelain compared to the impact of the other three factors, namely quartz content in the filler, firing temperature and soaking time that were tested. Thus,

optimization efforts should be focused on this factor. According to Stathis (2004), bending strength is affected by quartz grain size in two ways, directly through the induction of compressive stresses to the vitreous phase and indirectly through the development of a favourable microstructure. He stressed that both the parameters depend strongly on the particle distribution of quartz grains. He recorded the optimum quartz grain size is 5 – 20 µm which gives the maximum bending strength. However, he noticed that the use of coarser grain sizes results in reduced bending strength due to the development of a detrimental microstructure for the mechanical properties.

The chemical compositions of ceramic waste and porcelain tile powder has been established to vary greatly based on the type of ceramic tile. The main chemical components being SiO<sub>2</sub> which is found in the largest proportion followed by Al<sub>2</sub>O<sub>3</sub>. Other minor chemical constituents include Fe<sub>2</sub>O<sub>3</sub>, CaO, MgO, Na<sub>2</sub>O, K<sub>2</sub>O while TiO<sub>2</sub> is the least found chemical constituent. The chemical composition of the ceramic waste will also tend to influence the specific gravity of the ceramic waste as established by Siddesha, (2011) who conducted a study using homogeneous ceramic tiles.

## 3. MATERIALS AND METHODS

The vast majority of tile found on demolition sites in the Uganda is made with either ceramic or porcelain. Figure 2 shows a sample of ceramic and porcelain tile waste at one of the demolition site in Bukoto. Samples of ceramic and porcelain clay tiles was taken in accordance to BS 1881-101: 1983, which gives methods of sampling. Five kilograms of each material (ceramic and porcelain clay tiles) was picked from each of the five sampled sites within Kampala metropolitan area. They were washed and left to air dry, crushed in the laboratory into powder.



Figure 1: Ceramicclay tile waste at demolition site

Figure 2 describes the scientific experiments conducted using same basic elements albeit augmented by sophisticated tools and methods.

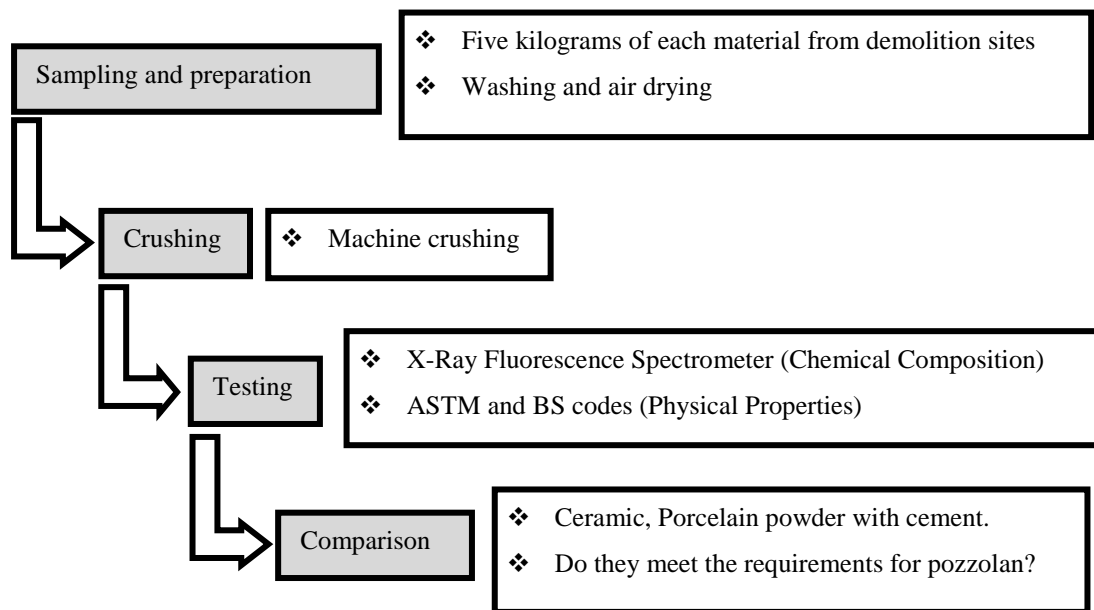

Figure 2: Experimental setup

The physical of crushed ceramic and porcelain clay tile was determined in accordance to the relevant standards. American Standard of Testing Materials (ASTM) and British Standard (BS) test methods were used to establish the physical and chemical properties of the crushed powder. X-Ray fluorescence Spectrometer method was used to determine the chemical composition of the crushed ceramic and porcelain clay tile powder. The test method used to establish each property is given in Table 1.

Table 1: Test Methods for properties of crushed ceramic and porcelain clay tile powder

Property	Test Method
Specific Gravity	ASTM C 188
Consistency	ASTM C 187
Setting Time	BS EN 196-3:2016
Chemical Composition	X-Ray Fluorescence Spectrometer

From the test results, conclusions were made to justify whether crushed ceramic and porcelain clay tiles possess adequate pozzolanic properties to warrant its use as partial cement substitute in concrete production.

#### 4. RESULTS AND DISCUSSION

Table 1: Physical properties of Cement, Ceramic and Porcelain powder

Property	Ordinary Portland Cement	Ceramic Powder	Porcelain Powder
Specific Gravity	3.15	2.95	3.11
Consistency	30	32.5	35.0
Initial Setting Time	30 minimum	70	45
Final Setting Time	540 maximum	475	320
Colour	Grey	Reddish Brown	Grey

Table 2: Chemical Composition Ceramic and Porcelain powder

Major Components	Chemical Composition (% by mass)		
	Ceramic powder	Porcelain powder	Ordinary Portland Cement Standard
SiO <sub>2</sub>	66.39	73.04	21.03
CaO	3.64	1.43	64.67
Al <sub>2</sub> O <sub>3</sub>	18.14	19.39	6.16
Fe <sub>2</sub> O <sub>3</sub>	3.79	1.42	2.58
MgO	3.60	1.58	2.62
K <sub>2</sub> O	3.39	2.56	0.61



The major compounds of ordinary Portland cement are listed in Table 2. About 95% of portland cement clinker is made of combinations of four oxides. These are: lime (CaO), silica (SiO<sub>2</sub>), alumina (Al<sub>2</sub>O<sub>3</sub>), and iron oxide (Fe<sub>2</sub>O<sub>3</sub>). Other, so-called minor constituents or impurities include, among others, magnesia; sodium, and potassium

oxides. Since the primary constituents of Portland cement are calcium silicates, one can define portland cement as a material that combines CaO and SiO<sub>2</sub> in such a proportion that the resulting calcium silicate will react with water at room temperature and normal pressure.

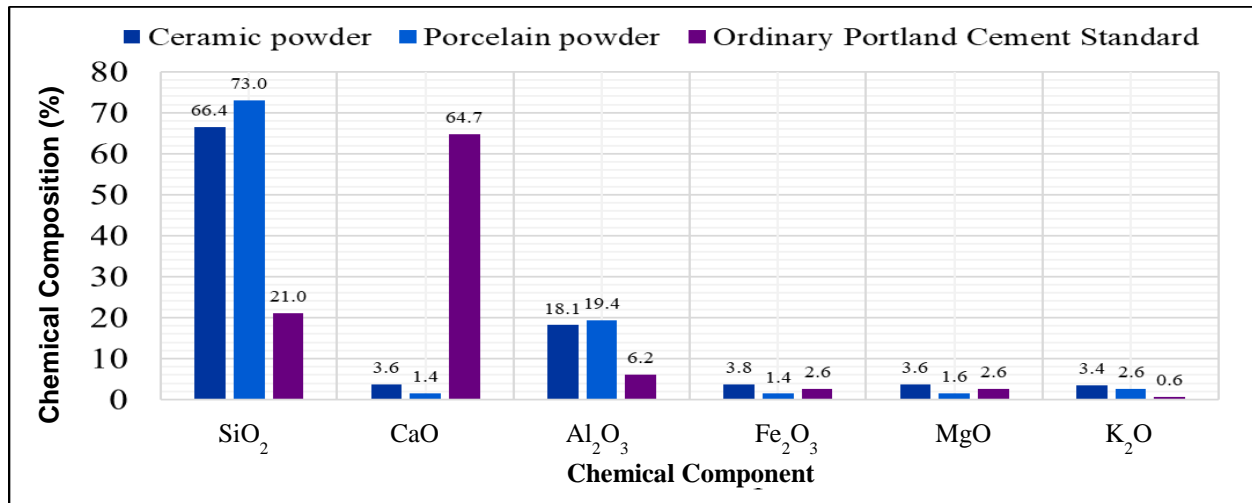

Figure 3: Chemical composition of cement, ceramic and porcelain powders

From Figure 3, it is clear that both ceramic and porcelain clay tile powder contain respectively 88.32% and 93.85% of SiO<sub>2</sub>, Fe<sub>2</sub>O<sub>3</sub> and Al<sub>2</sub>O<sub>3</sub>.

## 5. CONCLUSION

At the end of the study, the following conclusions are drawn:

- (i) The physical properties of crushed ceramic and porcelain clay tile powder are closely related to those of ordinary portland cement.
- (ii) From the Table 2, it can be seen that the combined percentage of silica (SiO<sub>2</sub>), iron oxide (Fe<sub>2</sub>O<sub>3</sub>), and alumina (Al<sub>2</sub>O<sub>3</sub>) for both crushed ceramic and porcelain clay tile powder was meeting the 70% minimum requirement of ASTM C 618 for a good pozzolan.

## 6. RECOMMENDATIONS

From this experimental study the following recommendations were made for further research:

- (i) For possible applications

- Crushed ceramic and porcelain clay tile powders may be used to replace cement partially or even at high proportions in the production of eco-friendly concrete.

(ii) For further study:

- Other physical properties such as fineness, specific surface, water demand, soundness, and density among others may be further studied.
- Mechanical and thermal properties of ceramic and porcelain clay tile powders should also be investigated.

## REFERENCES

- [1] ASTM C 187 – 16, Standard Test Method for Amount of Water Required for Normal Consistency of Hydraulic Cement Paste. ASTM International, Pennsylvania.
- [2] ASTM C188 – 17, Standard Test Method for Density of Hydraulic Cement. ASTM International, Pennsylvania.
- [3] Bragança, S.R., & Bergmann, C.P., (2004). Traditional and glass powder porcelain: Technical

- and Microstructure analysis. Journal of the European Ceramic Society.
- [4] BS 1881-101:1983, Method of sampling fresh concrete on site, British Standard Institution, London, UK.
- [5] BS EN 197-3, (2016), Method of testing cement: Determination of setting time and soundness. British Standard Institution, London, UK.
- [6] Buchanan, J. A., & Olupot, P. W., (2006). Characterization of Ceramic Raw Minerals in Uganda for Production of Electrical Porcelain Insulators. Proceedings from the International Conference on Advances in Engineering and Technology
- [7] Lopez-Gayarre, F., Lopez-Colina, C., Serrano-Lopez, M.A., Garcia Taengua, E., Lopez-Martinez, A., (2011). Assessment of properties of recycled concrete by means of a highly fractioned factorial design of experiment. Construction and Building Materials 25 (10): 3802–3809.
- [8] Pacheco, F., & Jalali, S., (2010). Reusing ceramic wastes in concrete. Construction and Building Materials, Volume 48, 2013, pp. 295-305.
- [9] Pérez, J. M., Rincón, J. M., & Romero, M., (2012). Effect of moulding pressure on microstructure and technological properties of porcelain stoneware. Ceramics International, 38(1), 317-325.
- [10] Siddesha, H., (2011). Experimental Studies on the Effect of Ceramic fine aggregate on the Strength properties of Concrete. International Journal of Advances in Engineering, Science and Technology (IJAEST).
- [11] Sivaprakash, G., Saravana, K., & Lakhi, J. S., (2016). Experimental study on partial replacement of sand by ceramic waste in concrete. Int. J. Chem. Sci.: 14(S1).
- [12] Stathis, G., Ekonomakou, A., Stournaras, C. J., (2004), Effect of firing conditions, filler grain size and quartz content on bending strength and physical properties of sanitaryware porcelain. Journal of the European Ceramic.